

BORDO[®]

INDUSTRIAL TOOLS



powercoil[®]

loksert[®]

tapsert[®]

Nes[®]

**THREADED INSERTS
& THREAD RESTORATION
BUYER'S GUIDE 03/2015**



powercoil[®]
wire thread insert system



	Free Running Insert Frei laufender Einsatz Filet rapporté standard Inserto standard 普通型螺套 フリーランニングインサート		8-UN Constant Pitch 8-UN konstante Steigung Pas constant 8-UN Rosca Americana paso 8 hilos 英制 8螺紋 8-UN一定ピッチ		MC, MF, UNC, UNF, 8 Pitch, NPT – HSS Bottoming STI Tap MC, MF, UNC, UNF, 8 Steigungs-, NPT – HSS vorschneider STI-Gewindeschneider Taraud STI finisseur MC, MF, UNC, UNF, 8 pas, NPT – HSS Machos STI de acabado, N° 3 – MC, MF, UNC, UNF, 8 UN, NPT 高速鋼螺套專用絲錐(底錐)適用於MC, MF, UNC, UNF, 8 UN, NPT螺紋 MC, MF, UNC, UNF, 8 Pitch, NPT – HSS STI上げタップ
	Screw Locking Insert Screwlockender Einsatz Filet rapporté à frein de vis Inserto autofrenante 鎖緊型螺套 ロックタイプインサート		British Association British Association Association britannique Rosca inglesa BA BA螺紋 英国協会		MC, MF, UNC, UNF, 8 Pitch, NPT – HSS Intermediate STI Tap MC, MF, UNC, UNF, 8 Steigung, NPT – HSS Einschnitt STI- Gewindeschneider Taraud STI intermédiaire MC, MF, UNC, UNF, 8 pas, NPT – HSS Machos STI intermedio, N° 2 – MC, MF, UNC, UNF, 8 UN, NPT 高速鋼螺套專用絲錐(中錐)適用於MC, MF, UNC, UNF, 8 UN, NPT螺紋 MC, MF, UNC, UNF, 8 Pitch, NPT – HSS STI中タップ
	Metric Coarse Metrisch Standard Métrique à pas normaux Métrica gruesa 公制粗牙螺紋 ミリ並目		British Standard Brass British Standard Brass Standard Anglaise BSCY Rosca inglesa BSC 英国标准(黃銅) 英国規格真鍮		MC, MF, UNC, UNF, 8 Pitch, NPT – HSS Taper STI Tap MC, MF, UNC, UNF, 8 Steigung, NPT – HSS fertigschneider STI-Gewindeschneider Taraud STI ébaucheur MC, MF, UNC, UNF, 8 pas, NPT – HSS Machos STI cónico, N° 1 – MC, MF, UNC, UNF, 8 UN, NPT 高速鋼螺套專用絲錐(頭錐)適用於MC, MF, UNC, UNF, 8 UN, NPT螺紋 MC, MF, UNC, UNF, 8 Pitch, NPT – HSS STI先タップ
	Metric Fine Metrisch Fein Métrique à pas fins Métrica fina 公制細牙螺紋 ミリ細目		Installed Insert Length = Diameter x 1.0 Installierte Einsatzlänge = Durchmesser x 1.0 Longueur du filet rapporté installé = Diamètre x 1.0 Longitud del inserto instalado = Diámetro x 1.0 安裝后螺套長度 = 直徑 *1.0 挿入インサート長さ = 直徑 x 1.0		BSW, BSF, BSP – HSS Bottoming STI Tap BSW, BSF, BSP – HSS vorschneider STI- Gewindeschneider Taraud STI finisseur STI BSW, BSF, BSP – HSS Machos STI de acabado, N° 3 – BSW, BSF, BSP 高速鋼螺套專用絲錐(底錐)適用於BSW, BSF, BSP螺紋 BSW, BSF, BSP – HSS STI上げタップ
	Unified National Coarse Unified National Standard Pas normal américain Rosca Americana gruesa 統一标准粗牙螺紋 ユニファイ並目		Installed Insert Length = Diameter x 1.5 Installierte Einsatzlänge = Durchmesser x 1.5 Longueur du filet rapporté installé = Diamètre x 1.5 Longitud del inserto instalado = Diámetro x 1.5 安裝后螺套長度 = 直徑 *1.5 挿入インサート長さ = 直徑 x 1.5		BSW, BSF, BSP – HSS Intermediate STI Tap BSW, BSF, BSP – HSS Einschnitt STI Gewindeschneider Taraud STI intermédiaire BSW, BSF, BSP – HSS Machos STI intermedio, N° 2 – BSW, BSF, BSP 高速鋼螺套專用絲錐(中錐)適用於BSW, BSF, BSP螺紋 BSW, BSF, BSP – HSS STI中タップ
	Unified National Fine Unified National Fein Pas fin américain Rosca Americana fina 統一标准細牙螺紋 ユニファイ細目		Installed Insert Length = Diameter x 2.0 Installierte Einsatzlänge = Durchmesser x 2.0 Longueur du filet rapporté installé = Diamètre x 2.0 Longitud del inserto instalado = Diámetro x 2.0 安裝后螺套長度 = 直徑 *2.0 挿入インサート長さ = 直徑 x 2.0		BSW, BSF, BSP – HSS Taper STI Tap BSW, BSF, BSP – HSS fertigschneider STI-Gewindeschneider Taraud STI ébaucheur BSW, BSF, BSP – HSS Machos STI cónico, N° 1 – BSW, BSF, BSP 高速鋼螺套專用絲錐(頭錐)適用於BSW, BSF, BSP螺紋 BSW, BSF, BSP – HSS STI先タップ
	British Standard Whitworth British Standard Whitworth Pas normal britannique Rosca inglesa gruesa 英制标准惠氏螺紋 英国規格ワイトワース		Installed Insert Length = Diameter x 2.5 Installierte Einsatzlänge = Durchmesser x 2.5 Longueur du filet rapporté installé = Diamètre x 2.5 Longitud del inserto instalado = Diámetro x 2.5 安裝后螺套長度 = 直徑 *2.5 挿入インサート長さ = 直徑 x 2.5		BA – HSS Bottoming STI Tap BA – HSS vorschneider STI-Gewindeschneider Taraud STI finisseur BA – HSS Machos STI de acabado, N° 3 – BA 高速鋼螺套專用絲錐(底錐)適用於BA螺紋 BA – HSS STI上げタップ
	British Standard Fine British Standard Fein Pas fin britannique Rosca inglesa fina 英制标准細牙螺紋 英国規格細目		Installed Insert Length = Diameter x 3.0 Installierte Einsatzlänge = Durchmesser x 3.0 Longueur du filet rapporté installé = Diamètre x 3.0 Longitud del inserto instalado = Diámetro x 3.0 安裝后螺套長度 = 直徑 *3.0 挿入インサート長さ = 直徑 x 3.0		BA – HSS Intermediate STI Tap BA – HSS Einschnitt STI- Gewindeschneider Taraud STI intermédiaire BA – HSS Machos STI intermedio, N° 2 – BA 高速鋼螺套專用絲錐(中錐)適用於BA螺紋 BA – HSS STI中タップ
	British Standard Pipe British Standard Pipe filet de tube britannique Rosca inglesa GAS 英制标准管螺紋 英国規格パイプ		HSS-EV Spiral Flute STI Tap HSS-EV Gerade STI- Gewindeschneider Taraud STI à rainures hélicoïdales HSS-EV Machos STI Helicoidal 螺旋槽絲錐 HSS-EV スパイラルフルートSTIタップ		BA – HSS Taper STI Tap BA – HSS fertigschneider STI- Gewindeschneider Taraud STI ébaucheur BA – HSS Machos STI cónico, N° 1 – BA 高速鋼螺套專用絲錐(頭錐)適用於BA螺紋 BA – HSS STI先タップ
	National Pipe Taper National Pipe Konus tube conique américain Rosca cónica Americana 标准管螺紋 アメリカ規格管用テーパ		HSS-EV Spiral Point (Gun Nose) STI Tap HSS-EV Drallspitzen (Tiefloch-) STI- Gewindeschneider Taraud STI à entrée hélicoïdale (nez mitrailleur) HSS-EV Machos STI con entrada corregida F/B 螺尖絲錐 HSS-EV スパイラルポイント(ガンノーズ)STIタップ		Spark Plug – HSS Pilot Nose STI Tap Zündkerze – HSS STI- Gewindeschneider mit Führungszapfen Taraud STI à embout pilote bougie d'allumage – HSS Machos STI con doble entrada para bujías 火花塞專用絲錐 スパークプラグ- HSS パイロットノーズSTIタップ

PowerCoil Wire Thread Inserts strengthen tapped threads in light weight parent materials such as aluminium. They are helically wound inserts made from high quality chromium nickel stainless steel with a diamond shaped cross section.

PowerCoil inserts are used in OEM applications in a wide range of industry sectors including aerospace, automotive, military and electronics. They are inexpensive when compared to other inserts and simple to install, yet are extremely tough, wear resistant and corrosion resistant.











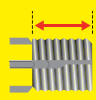

Most importantly, PowerCoil inserts allow the stress loading from the bolt or similar threaded part to be more evenly distributed over the threads in the parent material.

In addition to PowerCoils standard 'free running' inserts, 'screw locking' inserts are also available. These inserts have polygonal grip coils within the length of the insert which exert radial pressure on the male thread, thereby gripping the bolt and preventing it from loosening under vibration or impact.

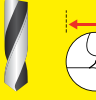
In addition to stainless steel, PowerCoil inserts can be made from Phosphor Bronze, Inconel or Nimonic 90 depending on the application. They can also be supplied with different surface finishes and coatings including cadmium, silver and zinc plating and dry film lubricant.

A complete range of Screw Thread Insert (STI) taps are available as well as low, medium and high volume installation tools and a wide range of individual and workshop. For further information we recommend you consult the technical pages in this guide, the PowerCoil website: www.powercoil.com.au or call your customer service representative.









						
Insert Internal Thread Einsatz internes Gewinde Filetage interne du filet rapporté Rosca interna del inserto 螺套内螺纹 インサート内部スレッド	Insert External Thread Einsatz externes Gewinde Filetage externe du filet rapporté Rosca externa del inserto 螺套外螺纹 インサート外部スレッド	Pitch (mm) Steigung (mm) Pas (mm) Paso en milímetros 螺距 (mm) ピッチ(mm)	Pitch (tpi) Steigung (tpi) Pas (tpi) Paso en dientes por pulgada 螺距 (tpi) ピッチ(tpi)	Insert Length Einsatzlänge Longueur du filet rapporté Longitud del inserto 螺套长度 インサートの長さ	# of Inserts # Einsätze Nb de filets rapportés Número de roscas del inserto 螺套数量 インサート数	Tapping Drill Size Gewindebohrer-Größe Dimension de l'avant-trou de taraudage Diámetro de la broca previa 钻头尺寸 タッピングドリルサイズ
						
Thread Tap Size Gewindeschneider-Größe Dimension du taraud de filetage Dimension del macho de roscar 丝锥尺寸 スレッドタップサイズ	Countersink Diameter Senkbohrer-Durchmesser Diamètre de la fraise Diámetro del avellanador 倒角直径 カウンタースク径	Installation Tool Part # Einbauwerkzeug # Herramienta de instalación N° Code pièce de l'outil d'installation 安装工具编号 挿入工具部品番号	Loksert Thin Wall Insert Loksert Thinwall Insert (dünnwandiger Einsatz) Loksert Thin Wall Insert (Filet rapporté Loksert à paroi mince) Inserto de seguridad Loksert de pared delgada Loksert 薄壁型螺套 Loksert(ロックサート) 薄肉インサート	Loksert Heavy Duty Insert Loksert Heavy-Duty Insert (Heavy-Duty Einsatz) Loksert Heavy Duty Insert (Filet rapporté Loksert à paroi renforcée) Inserto de seguridad Loksert reforzado Loksert 厚壁型螺套 Loksert(ロックサート) 高耐久型インサート		

Loksert solid keylocking inserts are an easily installed thread assembly that is ideal for replacing damaged or worn threads in virtually any material – ferrous, non-ferrous and non-metallic.

They are constructed from high quality carbon steel or extremely hard wearing stainless steel. One piece loksert inserts are supplied with the dove-tailed locking keys pre-assembled. Lokserts are suitable for repairing and creating threads in a wide range of applications including forgings and castings and are especially suited to situations that experience heavy wear and vibration - such as mining, construction and earthmoving equipment.

Features and Benefits

- Solid bushing utilising locking keys provides positive mechanical lock against rotation
- High strength and reliability provides maximum pullout strength
- Installed using standard drills and taps
- Simple installation - no special skills required
- Suitable for use in a wide range of parent materials
- Impossible to cross thread during installation
- Simple removal process if required
- No tang to break and remove
- Available in metric sizes, inch sizes and spark plug sizes
- Available in Thinwall and Heavy Duty

						
Insert Internal Thread Einsatz internes Gewinde Filetage interne du filet rapporté Rosca interna del inserto 螺套内螺纹 インサート内部スレッド	Insert External Thread Einsatz externes Gewinde Filetage externe du filet rapporté Rosca externa del inserto 螺套外螺纹 インサート外部スレッド	Pitch (mm) Steigung (mm) Pas (mm) Paso en milímetros 螺距 (mm) ピッチ(mm)	Pitch (tpi) Steigung (tpi) Pas (tpi) Paso en dientes por pulgada 螺距 (tpi) ピッチ(tpi)	Insert Length Einsatzlänge Longueur du filet rapporté Longitud del inserto 螺套长度 インサートの長さ	# of Inserts # Einsätze Nb de filets rapportés Número de roscas del inserto 螺套数量 インサート数	Tapping Drill Size Gewindebohrer-Größe Dimension de l'avant-trou de taraudage Diámetro de la broca previa 钻头尺寸 タッピングドリルサイズ

Tapserts are self cutting threaded inserts that feature both external and internal threads. They are driven into a pre-formed or pre-drilled retaining hole and the cutting slots (or cutting bores) effectively tap the hole as the insert is wound into the parent material.

Tapserts are available in case hardened steel or stainless steel.

Tapserts are ideal for use in low shear strength materials (such as alloys, plastics and castings) which require threaded seats with high load capacity and wear resistance.

Tapserts feature:

- High pull-out strength
- High loading capacity in low shear strength materials
- Wear free, vibration resistant screw joint
- Pre-cast or pre-drilled holes with standard tolerance
- No requirement for expensive thread tapping tools
- Retains and captures chips from installation in chipping reservoirs.



Part No. 3520 - 12.00 X 1.5D

- 35 PowerCoil - Stainless Steel
- 36 Loksert - Carbon Steel
- 37 Loksert - Stainless Steel

DIAMETER
XX . XX Metric
XX / XX Imperial

- | | |
|--------------------|---------|
| 20 Metric Coarse | 32 UNC |
| 21 Metric Fine | 34 UNF |
| 22 Spark Plug | 44 BA |
| 23 Metric Fine | 46 BSP |
| 24 Metric Fine | 52 NPT |
| 28 BSW | 60 BSC |
| 30 BSF | 70 8-UN |
| 00 Multifunctional | |

- X.X D** Insert length as a factor of nominal screw
- IR** PowerCoil strip-feed reel
 - SL** PowerCoil screw locking
 - K** PowerCoil thread repair kit
 - P** PowerCoil Hang sell insert packet
 - WK** PowerCoil workshop kit
 - HIT** Hand installation tool
 - HIP** Prewinder installation tool
 - MIT** Machine installation tool
 - HIM** Hex drive installation mandrel
 - MIP** Pneumatic installation tool
 - TB** Tang break tool
 - STB** Spring loaded tang break tool
 - PTB** Pneumatic tang break tool
 - RT** Removal/extraction tool
 - LH** Left Hand
 - GC** Gauge STI 4H5H tolerance
 - GM** Gauge STI 6H tolerance

- PB** Phosphor bronze
- IC** Inconel X-750
- NM** Nimonic 90
- NT** Nitronic 60
- Y** 316 Stainless Steel
- CD** Cadmium plate
- ZN** Zinc plate
- AG** Silver plate
- FL** Dry film lubricant
- I** Tap Intermediate STI
- T** Tap Taper STI
- B** Tap Bottoming STI
- SF** Tap Spiral Flute STI
- SP** Tap Spiral Point STI
- FT** Tap Fluteless STI
- TW** Loksert Thin Wall
- HD** Loksert Heavy Duty
- TT** Loksert Thin Wall install tool
- HT** Loksert Heavy Duty install tool
- T** Loksert Universal install tool



Teil-Nr. 3520 - 12.00 X 1.5D

- 35 PowerCoil - Edelstahl
- 36 Loksert - unlegierter Stahl
- 37 Loksert - Edelstahl

DURCHMESSER
XX . XX Metrisch
XX / XX Zoll

- | | |
|----------------------|---------|
| 20 Metrisch Standard | 32 UNC |
| 21 Metrisch fein | 34 UNF |
| 22 Zündkerze | 44 BA |
| 23 Metrisch fein | 46 BSP |
| 24 Metrisch fein | 52 NPT |
| 28 BSW | 60 BSC |
| 30 BSF | 70 8-UN |
| 00 Multi-funktionell | |

- X.X D** Einsatzlänge als Faktor der Nennschraube
- IR** PowerCoil Stripfeed-Rolle
 - SL** PowerCoil Screwlocking
 - K** PowerCoil Gewindereparatur-Sortiment
 - P** PowerCoil Hangsell-Einsatzpaket
 - WK** PowerCoil Werkstatt-Sortiment
 - HIT** Handeinbauwerkzeug
 - HIP** Vorspannpatronen-Einbauwerkzeug
 - MIT** Maschinelles Einbauwerkzeug
 - HIM** Hex-Drive-Einbauspindel
 - MIP** Pneumatisches Einbauwerkzeug
 - TB** Zapfenbrecher
 - STB** Vorgespannter Zapfenbrecher
 - PTB** Pneumatischer Zapfenbrecher
 - RT** Ausdrehwerkzeug
 - LH** Linksdrehend
 - GC** Maß STI - 4H5H Toleranz
 - GM** Maß STI - 6H Toleranz

- PB** Phosphor bronze
- IC** Inconel X-750
- NM** Nimonic 90
- NT** Nitronic 60
- Y** 316 Edelstahl
- CD** Kadmiert
- ZN** Galvanisiert
- AG** Versilbert
- FL** Trockenschmiermittel
- I** Gewindebohrer Einschnitt STI
- T** Gewindebohrer - konisch STI
- B** Gewindebohrer bodengehend STI
- SF** Gewindebohrer Gerade STI
- SP** Gewindebohrer Drallspitze STI
- FT** Gewindebohrer ohne Nuten STI
- TW** Loksert - dünnwandig
- HD** Loksert - Heavy-Duty
- TT** Loksert - dünnwandig; Einbauwerkzeug
- HT** Loksert - Heavy-Duty; Einbauwerkzeug
- T** Loksert Universal- Einbauwerkzeug



Pièce Nr. 3520 - 12.00 X 1.5D

- 35 PowerCoil - Acier inoxydable
- 36 Loksert - Acier au carbone
- 37 Loksert - Acier inoxydable

DIAMETER
XX . XX Métrique
XX / XX Impérial

- | | |
|---------------------------|---------|
| 20 Métrique à pas normaux | 32 UNC |
| 21 Métrique à pas fins | 34 UNF |
| 22 Bougie d'allumage | 44 BA |
| 23 Métrique à pas fins | 46 BSP |
| 24 Métrique à pas fins | 52 NPT |
| 28 BSW | 60 BSC |
| 30 BSF | 70 8-UN |
| 00 Multifonctionnel | |

- X.X D** Longueur du filet rapporté tel que facteur de serrage nominal
- IR** Moulinet d'entraînement de bande PowerCoil
 - SL** PowerCoil à frein de vis
 - K** kit de réparation de filets PowerCoil
 - P** Paquet de filets rapportés PowerCoil dans un emballage à système d'accroche PowerCoil kit d'atelier
 - WK** PowerCoil kit d'atelier
 - HIT** Outil d'installation manuel
 - HIP** outil d'installation de pré-enroulage
 - MIT** Outil d'installation de la machine
 - HIM** mandrin d'installation Hex
 - MIP** Outil pneumatique d'installation
 - TB** Tenon
 - STB** Tenon à ressort
 - PTB** Pneumatic tang break tool
 - RT** Outil de dépose / d'extraction
 - LH** Coupe à gauche
 - GC** Jauge STI de tolérance 4H5H
 - GM** Jauge STI de tolérance 6H

- PB** Bronze de phosphore
- IC** Inconel X-750
- NM** Nimonic 90
- NT** Nitronic 60
- Y** Acier inoxydable 316
- CD** Plaque de cadmium
- ZN** Plaque de zinc
- AG** Plaque d'argent
- FL** film de lubrifiant hydrofuge
- I** Taraud STI intermédiaire
- T** Taraud STI ébaucheur
- B** Taraud STI finisseur
- SF** Taraud STI à rainures hélicoïdales
- SP** Taraud STI à entrée hélicoïdale
- FT** Taraud STI sans goujure
- TW** Loksert à paroi fine
- HD** Loksert à paroi renforcée
- TT** Outil d'installation de Loksert à paroi fine
- HT** Outil d'installation de Loksert à paroi renforcée
- T** Outil d'installation universel de Loksert



No. De Parte 3520-12.00 X 1,5D

35	PowerCoil en acero inoxidable
36	Loksert en acero al carbón
37	Loksert en acero inoxidable

DIAMETER	
XX . XX	Métrico
XX / XX	Pulgadas

20	Métrico grueso	32	UNC
21	Métrico fino	34	UNF
22	Bujía	44	BA
23	Métrico fino	46	BSP
24	Métrico fino	52	NPT
28	BSW	60	BSC
30	BSF	70	8-UN
00	Multifuncional		

X.X D	Longitud del inserto teniendo en cuenta la longitud del tornillo	PB	Bronce con fósforo
IR	Power Coil, Carrete de alimentación de insertos	IC	Iconel X-750
SL	Power Coil, insertos autoblocantes (de seguridad) (autofrenantes)	NM	Nimonic 90
K	Power Coil, Juego de reparación de roscas	NT	Nitronic 60
P	Power Coil, paquetes de insertos para colgar	Y	Acero Inoxidable 316
WK	Power Coil, Juegos para taller	CD	Terminado en cadmio
HIT	Herramienta de instalación manual	ZN	Terminado de zinc
HIP	Herramienta de instalación de roscas	AG	Terminado de plata
MIT	Herramienta para insertar a máquina	FL	lubricado en seco
HIM	Herramienta para insertar con mango hexagonal	I	Macho 2º o intermedio STI
MIP	Herramienta de instalación neumática	T	Macho 1º o cónico STI
TB	Herramienta rompe arrastre	B	Macho 3º o de acabado STI
STB	Herramienta rompe arrastre automático	SF	Macho helicoidal STI
PTB	Herramienta rompe arrastre neumática	SP	Macho con entrada corregida STI
RT	Herramienta extractora de insertos	FT	Macho laminación STI
LH	Giro izquierda	TW	Loksert de pared delgada
GC	Roscas en tolerancia STI 4H5H	HD	Loksert para trabajos pesados (duros)
		TT	Herramienta instalación de Loksert de pared delgada
		HT	Herramienta instalación de Loksert para trabajos pesados
		T	Herramienta de instalación universal



Part No. 3520 - 12.00 X 1.5D

35	PowerCoil - 不锈钢
36	Loksert - 碳钢
37	Loksert - 不锈钢

直径	
XX . XX	公制
XX / XX	英制

20	公制粗牙	32	统一标准粗牙螺纹
21	公制细牙	34	统一标准细牙螺纹
22	火花塞	44	英国 BA 标准螺纹
23	公制细牙	46	英制标准管螺纹
24	公制细牙	52	标准管螺纹
28	英制标准惠氏螺纹	60	英国 BSC 螺纹
30	英制标准细牙螺纹	70	英制 8 螺纹
00	多功能的		

X.X D	螺孔倍率因子	PB	磷铜
IR	PowerCoil 盘装螺套	IC	因科镍合金
SL	PowerCoil 自锁型螺套	NM	镍锰合金
K	PowerCoil 螺纹修理套装	NT	Nitronic60 合金
P	PowerCoil 悬挂螺套包	Y	316 不锈钢
WK	PowerCoil 车间修理套装	CD	镀铜
		ZN	镀锌
		AG	镀银
		FL	干性润滑剂涂层
HIT	手动安装工具	I	中锥
HIP	预拉伸安装工具	T	头锥
MIT	机用安装工具	B	底锥
HIM	HEX 安装心轴	SF	螺旋槽丝锥
MIP	气动安装工具	SP	螺尖丝锥
TB	安装柄折断工具	FT	挤压丝锥
STB	伸缩折断工具	TW	Loksert 薄壁型螺套
PTB	气动折断工具	HD	Loksert 厚重型螺套
RT	螺套拆除工具	TT	Loksert 薄壁型螺套安装工具
LH	左手	HT	Loksert 厚重型螺套安装工具
GC	STI 专用量规 (4H,5H)	T	Loksert 通用安装工具
GM	STI 专用量规 (6H)		



部品番号 3520-12.00 X 1.5D

35	PowerCoil - ステンレス網
36	Loksert - カーボン網
37	Loksert - ステンレス網

径	
XX . XX	メートル法
XX / XX	インチ法

20	ミリ並目	32	UNC
21	ミリ細目	34	UNF
22	スパークプラグ	44	BA
23	ミリ細目	46	BSP
24	ミリ細目	52	NPT
28	BSW	60	BSC
30	BSF	70	8-UN
00	多機能性		

X.X D	呼びねじ寸法の倍数としてのインサートの長さ	PB	りん青銅
IR	Power Coil ストリップフィードリール	IC	インコネルX-750
SL	Power Coil ロックタイプ	NM	ナイモニック90
K	Power Coil ねじ山補修キット	NT	ニトロニック60
P	Power Coil ハングセルインサートパッケージ	Y	316ステンレス網
WK	Power Coil 作業キット	CD	カドミウムメッキ
HIT	手動挿入工具	ZN	亜鉛メッキ
HIP	プリワインダー挿入工具	AG	銀メッキ
MIT	電動挿入工具	FL	ドライフィロム潤滑材
HIM	6角ドライブ挿入マンドレル	I	STI中タップ
MIP	エアース挿入工具	T	STI先タップ
TB	タンク折取工具	B	STI上げタップ
STB	スプリング式タンク折取工具	SF	STIスパイラルフルートタップ
PTB	エアースタンク折取工具	SP	STIスパイラルポイントタップ
RT	取出し/抜取り工具	FT	STIフルートレス溝なしタップ
LH	左(巻き方向)	TW	薄肉ロックサート
GC	STI 4H5H公差ゲージ	HD	高耐久性ロックサート
		TT	薄肉ロックサート挿入工具
		HT	高耐久性ロックサート挿入工具
		T	Loksert(ロックサート)



powercoil[®]
wire thread insert system

Introduction to Wire Thread Inserts..... 2
 Repair Kits..... 6
 Workshop (Range) Kits..... 11
 Insert Hang Sell (Retail) Packets..... 13
 Merchandisers 23
 Bulk Inserts 26
 Strip Feed 46
 STI Taps 48
 Installation and Removal Tools..... 53



loksert[®]

Repair Kits..... 60
 Insert Hang Sell (Retail) Packets..... 62
 Merchandiser 63
 Bulk Thinwall Inserts..... 64
 Bulk Heavy Duty Inserts 66
 Drills and Taps..... 70
 Installation Tools 72



tapsert[®]

Hang Sell (Retail) Repair Kits..... 74
 Merchandiser 75
 Bulk Inserts 76



Nes[®]

Threadmate Kit and Accessories..... 78
 External Thread Restorers..... 79
 Internal Thread Restorers 80
 Merchandiser 81
 Thread Restoration Kits..... 82

Technical – PowerCoil 84
Technical – Loksert 92
Technical – Tapsert 94

German, French, Spanish, Chinese, Japanese

Introduction to PowerCoil® Wire Thread Inserts..... 97
 Introduction to Loksert® Solid Keylocking Inserts 112

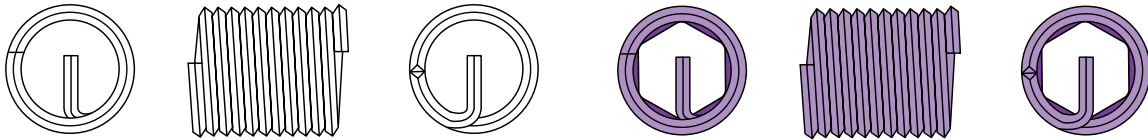

Manufactured from high quality chromium nickel stainless steel, PowerCoil Wire Thread Inserts provide high strength internal threads that resist the effects of temperature and corrosion. Their unique design ensures superior threads whose compound performance cannot be reproduced by any other single fastening method. Available in two basic forms, free running or screw locking, they are much lighter and less expensive than any other equivalent type of thread insert and because of their compact size they can generally be incorporated into existing designs where no previous provision has been made.

FREE RUNNING

Produced from precision profiled austenitic stainless steel wire wound into a helical spiral, PowerCoil free running inserts have a spring like appearance. When installed, using any one of a variety of manual or automatic tools, they provide strong permanent internal threads which resist heat and corrosion. Once fitted, their position is maintained by the action of radial pressure between their coils and the flanks of the tapped hole. This pressure exists because their free diameter is larger by a calculated amount, than their installed diameter.

SCREW LOCKING

Screw locking (or prevailing torque) inserts are of particular value in applications subject to the effects of cyclic vibration or impact. In addition to the benefits afforded by free running inserts, PowerCoil screw locking inserts offer the additional security of prevailing locking torque. This is achieved by the action of one or more polygonal grip coils positioned within the insert's length, which exert radial pressure on the male thread. Each grip coil consists of a number of tangential locking chords which protrude inside the minor diameter of the normal free running coils. As the male thread passes through these grip coils, the locking flats are displaced thus exerting radial pressure or prevailing torque on the male thread. On removal of the male thread, the locking coils relax to their original form permitting repeated assembly whilst retaining a measurable level of prevailing torque.

Note: It is recommended that only close fit plated or lubricated bolts or screws are used with screw locking inserts.

FEATURES & BENEFITS

For many years, helically coiled wire thread inserts have been vastly underestimated. The popular misconception that they were designed for the repair of damaged threads has given this unique fastener a false image.

They are much lighter and less expensive than any other equivalent type of thread insert and because of their compact size, can generally be introduced into existing designs where no previous provision has been made. Unlike many other economic measures, their introduction increases quality and performance whilst reducing overall product cost. Their introduction may result in the use of thinner sections or lighter parent materials without sacrificing thread strength.

They protect tapped threads against failures due to stripping, seizing, corrosion and wear. PowerCoil wire thread inserts are produced from austenitic stainless steel wire which is work hardened to a tensile strength above 200,000psi and a hardness of Rc43-50. The inserts have an exceedingly smooth surface finish which virtually eliminates friction-induced thread erosion.

The continuous helically coiled design negates the need for thick wall structures to support the internal and external threads - the diamond profile wire coil is the thread. PowerCoil wire thread inserts can be installed in reduced size bosses or flanges

and within constricted areas – saving space and weight while providing high strength.

A boss radius equal to the nominal bolt diameter is usually sufficient.

A complete range of installation tools are available to suit specific production techniques. A range of hand tools exist for small runs and repairs; electric and pneumatic tools are available for high volume production requirements.

STRENGTH

Due to their flexibility, wire thread inserts create internal threads which have a much improved distribution of residual stress loading when compared with conventional tapped holes, where 75% of the shearing forces are carried by the first three threads in the tapped hole. The flexibility of wire thread inserts helps to compensate for pitch and flank angle errors, inherent in normal tapped holes, and significantly enhances the load bearing capacity by deflecting the residual forces into a helical hoop stress which is dispersed into the wall of the tapped hole. This enables the design to be confidently based on the bolt strength utilising smaller and shorter threads even when used in low strength materials.

The high tensile coils of a wire thread insert undergo a diameter reduction during installation. The outward spring-like force of the coils "locks" the insert into place.

Each coil can flex independently to contact the greatest amount of parent material thread surface. Both static and dynamic load bearing capabilities are improved.

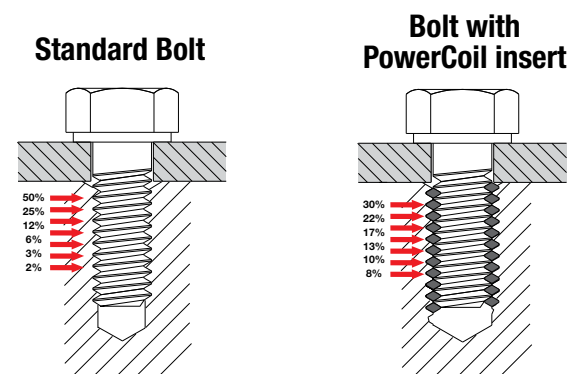

ELIMINATE STRESS

Virtually no stress is introduced into the parent material because there is no staking, locking, swaging or keying in place. The outward "spring action" of the insert holds it in place.

WEAR RESISTANCE

The combination of material hardness and the brilliant surface finish of wire thread inserts creates internal threads in which wear due to thread friction is virtually eliminated. This is of particular value in applications requiring repeated assembly & disassembly. The low frictional coefficient ensures that virtually all of the applied assembly torque is converted into clamping load. Thus providing threads that stay tight.

CORROSION PROTECTION

The 18/8 austenitic stainless steel wire used in PowerCoil inserts resists corrosion under normal environmental conditions. Galvanic action within the thread assembly is reduced, increasing the life of the fastening assembly.

Galvanic corrosion is most significant form of corrosion affecting

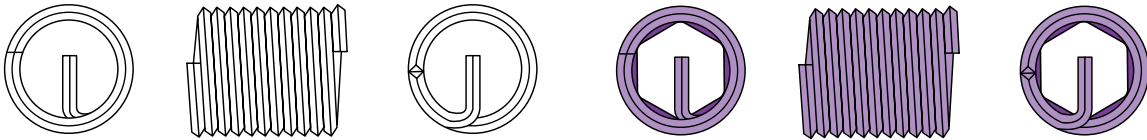

inserts and fasteners. Galvanic corrosion occurs when dissimilar metals are in contact in the presence of an electrolytic solution. All metals exhibit different degrees of “activity” or “nobility” and can be arranged in a galvanic series of increasing activity. Gold and platinum are most noble while zinc and magnesium are most active. The most common electrolytic solution encountered is ordinary water. Seawater or salt spray is more damaging because of high concentrations of dissolved salts.

The best way to preclude galvanic corrosion is to use similar potential metals and eliminate the electrolyte conductor. The active stainless steel of PowerCoil wire thread inserts are not passivated. This minimizes the possibility of galvanic corrosion occurring when they are installed in aluminum or magnesium parent materials.

Some additional precautions for reducing galvanic corrosion are:

1. Isolate the fasteners from the electrolyte. This can be done through gasketing or sealing.
2. Specify cadmium plated inserts. The cadmium plate provides a sacrificial barrier against corrosion. In addition, the cadmium plate has lubricating properties that minimize galling when stainless steel screws are used.
3. Apply corrosion inhibiting pastes or compounds to the screw. These include zinc chromate primer (MIL-P-8585) and strontium chromate primer (MIL-P-23377). Note: Pastes applied to the PowerCoil Thread Insert can become trapped between the wire and the hole and cause loss of proper tolerance. It is therefore recommended to apply the paste only to the screw, not the insert. If zinc chromate primer is applied to the tapped hole it should be thinned and applied sparingly. The insert should be installed while the primer is still wet.
4. Specify a dry film lubricant such as molybdenum disulphide on the inserts. This provides a secondary barrier against corrosion.
5. Where practical or where it will not interfere with the completed assembly, the external joint should be coated with a suitable paint.

MATERIALS

PowerCoil standard inserts are manufactured from fully certified, aircraft quality, 304 (18/8) austenitic stainless steel in accordance with DTD 734A. Alternative materials include 316 stainless steel and a variety of application specific surface coatings.

ALTERNATIVE MATERIALS

Phosphor Bronze

Non ferrous copper/tin alloy in accordance with BS2783 PB 102 EH – is suitable for operation in temperatures ranging from -200°C to +300°C.

Inconel X-750

Heat resisting precipitation hardenable nickel base alloy (equivalent specifications SAE AS 7246, DIN/NF 3018, W.NR 2.4669, UNS N07750). Inconel X-750 is suitable for operation in temperatures ranging from -200°C to +550° degrees celsius.

Nimonic 90

Heat resisting precipitation hardenable nickel base alloy in accordance with BS2 HR 501 (equivalent specifications W.NR 2.4632, UNS N07090).

Nimonic 90 is suitable for operation in temperatures ranging from -100°C to +650° degrees celsius.

Insert Material	Max. Peak Temp.	Cont.	Typical Applications	Coatings
Stainless 304	425°C 800°F	315°C 600°F	Most general applications in all materials	FL, AG, CD
Stainless 316	425°C 800°F	315°C 600°F	Increased corrosion resistance for salt water applications	FL, AG, CD
Phosphor Bronze	300°C 572°F	235°C 455°F	Copper parts, non-magnetic, low permeability applications	AG, CD
Inconel X-750	650°C 1200°F	550°C 1020°F	Aerospace, turbines, corrosive environments, high temp. use	AG
Nimonic 90	650°C 1200°F	550°C 1020°F	Aerospace and turbine applications	AG

ALTERNATIVE FINISHES & COATINGS

Cadmium Plate

Electro-deposited Cadmium in accordance with DTD 904/Def Stan 03-19 (equivalent specifications FED. QQ-P-416, LN 9368). Cadmium plating provides an excellent barrier between dissimilar metals dramatically reducing the effects of galvanic corrosion, its high lubricity and excellent corrosion resistance prevents seizure and galling between threaded components. Cadmium plate is suitable for operation in temperatures ranging from -200°C to +235°C.

Cadmium plated parts must not be

- subjected to temperatures exceeding 235°C (455°F)
- come into contact with fuel or hot oil
- come into contact with food or drinking water
- be used with titanium components (either directly or indirectly). At elevated temperatures embrittlement and subsequent component failure may occur.
- Cadmium is highly toxic – consequently extreme care must be taken when shipping, handling and installing.

Zinc Plate

Electrolytically deposited zinc in accordance with BS 3382. Electro-deposited zinc is the most widely applied electroplated finish in industry. Zinc is suitable for operation in temperatures ranging from -200°C to +250°C.

Silver Plate

Electrolytically deposited silver in accordance with DTD 939. Silver plating is used to prevent seizure and galling between thread components in high temperature applications and is most commonly applied to aero-engine fasteners. Silver plate is suitable for operation in temperatures ranging from -200°C to +650°C. Silver plated wire inserts may be installed in various materials including aluminium alloys, magnesium alloys, corrosion and heat resistant materials etc.

Silver plated inserts are not recommended for installation in titanium alloy which may exceed a service temperature of 300°C (570°F). Stress corrosion as a result of the combination of silver and titanium may occur in the housing material.

Dry Film Lubricant

Solid film heat cured molybdenum disulphide dry film lubricant coating in accordance with MIL-L-0046010 provides a low frictional coefficient coating with excellent load bearing capabilities. Dry film lubricant prevents seizing and galling between threaded components and is particularly effective in screw locking insert applications. Dry film lubricant is suitable for operation in temperatures ranging from -100°C to +250°C.

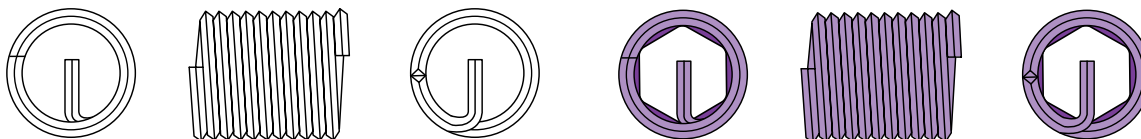

Plating / Finish	Part No. Suffix	Applicable Process Specification
Silver Plating	AG	DTD 939
Cadmium Plating	CD	QQP-416 or DEF STD 03-19
Dry Film Lubricant	FL	MIL-L-8937 or MIL-L-46010
Red Dye	—	Applied to locking inserts for identification purposes*

* other color dyes may also be utilised for specific identification purposes

SELECTION OF CORRECT INSERT LENGTH

PowerCoil wire thread inserts are available in all popular thread types. Five insert lengths are available for each thread size. It is important to select the correct insert length in order to balance the bolt tensile strength against the shear strength of the parent material. The five insert lengths (recommended thread engagement of the PowerCoil wire thread insert), 1D, 1.5D, 2D, 2.5D and 3D are shown in the shaded area of the table below. These are calculated numbers since the inserts cannot be measured in the free (un-installed) state. The numbers are multiples of the nominal thread size, or diameter, of the insert. The actual insert lengths in the installed position are listed in the insert selection tables. There they represent the actual installed length plus 1/2 pitch. Using the table below, an insert length can be selected which will produce a thread system strong enough to fracture a bolt before it will strip or damage either the parent material or the insert.

Recommended Nominal Insert lengths Based on Parent Material Versus Bolt Material Strengths

UNIFIED (source BS7752 Part 1:1994)

Shear Strength of Parent Material (KSI)	Bolt Material Minimum Ultimate Tensile Strength (KSI)								
	54	75	96	108	125	132	160	180	220
10	2.0	2.5	3.0	3.0	—	—	—	—	—
15	1.5	1.5	2.0	2.5	2.5	3.0	—	—	—
20	1.0	1.5	1.5	2.0	2.0	2.0	2.5	3.0	3.0
25	1.0	1.0	1.5	1.5	1.5	2.0	2.0	2.5	2.5
30	1.0	1.0	1.0	1.5	1.5	1.5	2.0	2.0	2.5
40	1.0	1.0	1.0	1.0	1.0	1.5	1.5	1.5	2.0
50	1.0	1.0	1.0	1.0	1.0	1.0	1.0	1.5	1.5

EXAMPLE: If parent material shear strength is 10KSI and the bolt tensile strength is 54 KSI, the correct insert length is 2.0 diameters (2D).

METRIC

Shear Strength of Parent Material (MPa)	Bolt Material Minimum Ultimate Tensile Strength (MPa)								
	300	400	500	600	800	1000	1200	1400	
70	1.5	2.0	2.5	2.5	—	—	—	—	—
100	1.0	1.5	1.5	2.0	2.5	3.0	—	—	—
150	1.0	1.0	1.5	1.5	2.0	2.0	2.5	3.0	
200	1.0	1.0	1.0	1.0	1.5	1.5	2.0	2.5	
250	1.0	1.0	1.0	1.0	1.0	1.5	1.5	2.0	
300	1.0	1.0	1.0	1.0	1.0	1.5	1.5	1.5	
350	1.0	1.0	1.0	1.0	1.0	1.0	1.5	1.5	

EXAMPLE: If parent material shear strength is 150Mpa and the bolt tensile strength is 600Mpa, the correct insert length is 1.5 diameters (1.5D).

BOLT PROJECTION

PowerCoil wire thread inserts are designed to be used with standard, readily available bolts and screws that require no special hardware.

The bolt must engage the entire insert length to achieve maximum assembly strength. To ensure against partial engagement, it is recommended that the tang always be removed. This will also guarantee that the locking coil(s) will be engaged by the full threads of the bolt. If design parameters prevent this, contact PowerCoil for assistance.

NOTES:

1. Bolt tensile strengths are specified minimums. When choosing an insert length, consideration should be given the maximum tensile strength allowed by the bolt drawing or procurement specification.
2. Service temperatures can cause significant variations in strength values, therefore compensation should be allowed.
3. The importance of shear values should be kept in mind because the parent material is subject to shear ing stress near the major diameter of the tapped threads.
4. When the strength values fall between two values in the tables, use next lower material shear value, or the next higher bolt tensile strength value.
5. To achieve maximum strength, bolt length and thread length as well as full tapped thread depth must be sufficient to assure full thread engagement over the entire length of the insert.

SCREW LOCKING (PREVAILING TORQUE) INSERTS

Screw Locking PowerCoil wire thread inserts are designed for applications subject to the effects of cyclic vibration or impact. The screw locking insert exerts a prevailing torque on male threaded fasteners to prevent loosening due to vibration or impact. They eliminate the need for other, less desirable and costly locking mechanisms. They are excellent in “adjusting screw” applications by preventing the male fastener from creeping.

HOW SCREW LOCKING INSERTS WORK

PowerCoil Screw Locking inserts offer the additional security of prevailing locking torque. This is achieved by the action of one or more polygonal grip coils positioned within the insert's length, which exert radial pressure on the male thread. Each grip coil consists of a number of tangential locking chords which protrude inside the minor diameter of the normal free running coils. As the male thread passes through these grip coils, the locking flats are displaced and exert radial pressure (prevailing torque) on the male thread.

On removal of the male thread, the locking coils relax to their original form permitting repeated assembly whilst retaining a measurable level of prevailing torque.

Please note:

It is recommended that only close fit plated or lubricated bolts or screws are used with screw locking PowerCoil wire thread inserts. When using heat treated unplated or stainless steel bolts, an anti-seize compound, e.g., molybdenum disulfide, must be used in order to minimize galling and assure maximum cycle life. Wear life of screw or bolt using PowerCoil screw locking wire thread inserts can also be improved by specifying dry film lubrication or cadmium plating.

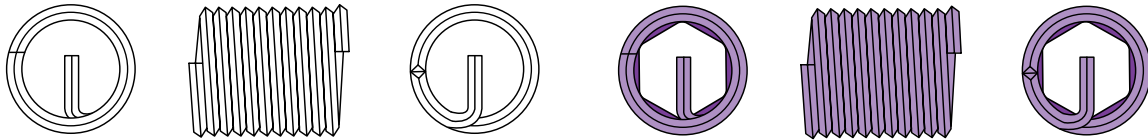

LOCATION OF LOCKING COILS

For 1D, 1.5D, and 2D diameter lengths: The center of the locking coil (or coils) equals 1/2 the number of free coils. For 2.5D and 3D diameter lengths: The locking coil is located the same distance from the tang as 2D length inserts.

Screw locking inserts are dyed red for easy identification purposes only. It is alcohol soluble and can be removed if desired.

RED DYE COATING

PowerCoil screw locking inserts are generally colour coded with an organic red dye for identification purposes. The dye does not affect the installation or performance of the insert and does not need to be removed (in most situations). In situations requiring extreme cleanliness (such as assembly of precision instruments in clean room conditions) the dye may be removed by soaking the inserts in a denatured alcohol solution prior to installation.

POWERCOIL LOCKING INSERT TORQUE VALUES

METRIC COARSE

Thread mm x mm	Torque Max (Nm)	Torque Min (Nm)
M2.2x0.45	0.14	0.02
M2.5x0.45	0.23	0.05
M3.0x0.50	0.45	0.10
M3.5x0.60	0.68	0.12
M4.0x0.70	0.90	0.15
M5.0x0.80	1.60	0.30
M6.0x1.00	3.00	0.40
M7.0x1.00	4.50	0.60
M8.0x1.25	6.00	0.80
M10.0x1.50	10.50	1.40
M12.0x1.75	15.50	2.10
M14.0x2.00	23.50	3.00
M16.0x2.00	31.50	4.20
M18.0x2.50	42.00	5.50
M20.0x2.50	54.00	7.00
M22.0x2.50	67.50	9.00
M24.0x3.00	80.00	10.50
M27.0x3.00	94.00	12.00
M30.0x3.50	108.00	14.00
M33.0x3.50	122.00	15.50
M36.0x4.00	136.00	17.50
M39.0x4.00	150.00	19.50

METRIC FINE

Thread mm x mm	Torque Max (Nm)	Torque Min (Nm)
M8.0x1.00	6.00	0.80
M10.0x1.00	10.50	1.40
M10.0x1.25	10.50	1.40
M12.0x1.25	15.50	2.10
M12.0x1.50	15.50	2.10
M14.0x1.50	23.50	3.00
M16.0x1.50	31.50	4.20
M18.0x1.50	42.00	5.50
M20.0x1.50	54.00	7.00
M22.0x1.50	67.50	9.00
M18.0x2.00	42.00	5.50
M20.0x2.00	54.00	7.00
M22.0x2.00	67.50	9.00
M24.0x2.00	80.00	10.50
M27.0x2.00	94.00	12.00
M30.0x2.00	108.00	14.00
M33.0x2.00	122.00	15.50
M36.0x2.00	136.00	17.50
M39.0x2.00	150.00	19.50
M36.0x3.00	136.00	17.50

Locking torque values conform to
MP3329, MP3330, MP3331

UNIFIED NATIONAL COARSE – UNC

Thread inch x tpi	Torque Max (lb in)	Torque Min (lb in)
2x56	1.25	0.19
3x48	2.00	0.44
4x40	3.00	0.63
5x40	4.69	0.81
6x32	6.00	1.00
8x32	9.00	1.50
10x24	13.00	2.00
12x24	24.00	3.00
1/4x20	30.00	4.50
5/16x18	60.00	7.50
3/8x18	80.00	12.00
7/16x14	100.00	16.50
1/2x13	150.00	24.00
9/16x12	200.00	30.00
5/8x11	300.00	40.00
3/4x10	400.00	60.00
7/8x9	600.00	82.00
1x8	800.00	110.00
11/8x7	900.00	137.00
11/4x7	1000.00	165.00
13/8x6	1150.00	185.00
11/2x6	1350.00	210.00

UNIFIED NATIONAL FINE – UNF

Thread inch x tpi	Torque Max (lb in)	Torque Min (lb in)
3x56	0.13	0.44
4x48	0.19	0.63
6x40	6.00	1.00
8x36	9.00	1.50
10x32	13.00	2.00
1/4x28	30.00	3.50
5/16x24	60.00	6.50
3/8x24	80.00	9.50
7/16x20	100.00	14.00
1/2x20	150.00	18.00
9/16x18	200.00	24.00
5/8x18	300.00	32.00
3/4x16	400.00	50.00
7/8x14	600.00	70.00
1x12	800.00	90.00
11/8x12	900.00	117.00
11/4x12	1000.00	143.00
13/8x12	1150.00	165.00
11/2x12	1350.00	190.00

Locking torque values conform to
NASM8846

Note: It is also essential that the bolt fully engages all insert coils for maximum strength.

PowerCoil screw locking inserts can be designed to suit a customer's specific needs. In certain instances and applications prevailing torque can be lessened or increased to cater for a specific application. In these situations please contact your PowerCoil representative to discuss your specific requirements.

Please Note: Installation of PowerCoil screw locking inserts requires the use of a pre-winder tool. Please discuss other installation options with your PowerCoil agent.



GROUP	PCRK
INSERT TYPE	WIRE THREAD
INSERT MATERIAL	304 STAINLESS STEEL
STYLE	FREE RUNNING

METRIC COARSE

MM	MM	INSTALLED LENGTH	€	PART #	#	MM	PART #	PART #	PART #
2.00	0.40	1.5D 3.00MM	52.50	3520-2.00K	20	2.1	3520-2.00I	3500-HIT2	3500-TB1
2.20	0.45	1.5D 3.30MM	52.50	3520-2.20K	20	2.3	3520-2.20I	3500-HIT2	3500-TB2
2.50	0.45	1.5D 3.75MM	39.90	3520-2.50K	20	2.6	3520-2.50I	3500-HIT3	3500-TB3
3.00	0.50	1.5D 4.50MM	38.85	3520-3.00K	20	3.2	3520-3.00I	3500-HIT4	3500-TB4
3.50	0.60	1.5D 5.25MM	39.90	3520-3.50K	20	3.7	3520-3.50I	3500-HIT5	3500-TB5
4.00	0.70	1.5D 6.00MM	38.85	3520-4.00K	20	4.2	3520-4.00I	3500-HIT6	3500-TB6
5.00	0.80	1.5D 7.50MM	38.85	3520-5.00K	20	5.2	3520-5.00I	3500-HIT8	3500-TB8
6.00	1.00	1.5D 9.00MM	40.95	3520-6.00K	20	6.3	3520-6.00I	3500-HIT9	3500-TB9
7.00	1.00	1.5D 10.50MM	50.40	3520-7.00K	20	7.3	3520-7.00I	3500-HIT10	3500-TB11
8.00	1.25	1.5D 12.00MM	47.25	3520-8.00K	20	8.3	3520-8.00I	3500-HIT11	3500-TB12
9.00	1.25	1.5D 13.50MM	58.80	3520-9.00K	15	9.4	3520-9.00I	3500-HIT13	3500-TB12
10.00	1.50	1.5D 15.00MM	50.40	3520-10.00K	15	10.4	3520-10.00I	3500-HIT13	3500-TB13
11.00	1.50	1.5D 16.50MM	61.95	3520-11.00K	10	11.4	3520-11.00I	3500-HIT14	3500-TB14
12.00	1.75	1.5D 18.00MM	60.90	3520-12.00K	10	12.4	3520-12.00I	3500-HIT15	3500-TB15
13.00	1.75	1.5D 19.50MM	73.50	3520-13.00K	10	13.5*	3520-13.00I	3500-HIT15	-
14.00	2.00	1.5D 21.00MM	82.95	3520-14.00K	10	14.5*	3520-14.00I	3500-HIT16	-
15.00	2.00	1.5D 22.50MM	94.50	3520-15.00K	10	15.5*	3520-15.00I	3500-HIT16	-
16.00	2.00	1.5D 24.00MM	82.95	3520-16.00K	10	16.5*	3520-16.00I	3500-HIT18	-
18.00	2.50	1.5D 27.00MM	94.50	3520-18.00K	5	18.5*	3520-18.00I	3500-HIT20	-
20.00	2.50	1.5D 30.00MM	105.00	3520-20.00K	5	20.8*	3520-20.00I	3500-HIT21	-
22.00	2.50	1.5D 33.00MM	126.00	3520-22.00K	5	22.8*	3520-22.00I	3500-HIT22	-
24.00	3.00	1.5D 36.00MM	141.75	3520-24.00K	5	25.0*	3520-24.00I	3500-HIT23	-
27.00	3.00	1.5D 40.50MM	294.00	3520-27.00K	5	28.0*	3520-27.00I	3500-HIT24	-
30.00	3.50	1.5D 45.00MM	351.75	3520-30.00K	5	31.0*	3520-30.00I	3500-HIT25	-
33.00	3.50	1.5D 49.50MM	372.75	3520-33.00K	5	34.0*	3520-33.00I	3500-HIT26	-
36.00	4.00	1.5D 54.00MM	404.25	3520-36.00K	5	37.0*	3520-36.00I	3500-HIT28	-

* Tapping drill not included in thread repair kit.



Some large repair kits over 24mm may be supplied with HIM tools (hex installation mandrels) in place of HIT tools (hand installation tools).

SPARK PLUG

MM	MM	INSTALLED LENGTH	€	PART #	#	MM	PART #	PART #	PART #
10.00	1.00	- 1/2"	70.35	3522-10.00K	5	-	3522-10.00PN	3500-HIT13	3500-TB13
-	-	- 0.339"	-	-	5	-	-	-	-
12.00	1.25	- 1/2"	74.55	3522-12.00K	5	-	3522-10.00PN	3500-HIT15	3500-TB15
-	-	- 3/4"	-	-	5	-	-	-	-
14.00	1.25	- 3/8"	89.25	3522-14.00K	5	-	3522-14.00PN	3500-HIT17	-
-	-	- 1/2"	-	-	5	-	-	-	-
-	-	- 3/4"	-	-	5	-	-	-	-
14.00	1.25	8.4MM	89.25	3522-14.00K1	5	-	3522-14.00PN	3500-HIT17	-
-	-	12.4MM	-	-	5	-	-	-	-
-	-	16.4MM	-	-	5	-	-	-	-
18.00	1.50	- 1/2"	131.25	3522-18.00K	5	-	3522-18.00PN	3500-HIT20	-

STI Pilot Nose Taps are used to repair damaged threads and do not require the drilling of a pilot hole.

These taps use the existing thread as a guide in tapping a straight hole. STI Pilot Nose Taps are most commonly used to tap holes for the repair of spark plug threads.



GROUP	PCRK
INSERT TYPE	WIRE THREAD
INSERT MATERIAL	304 STAINLESS STEEL
STYLE	FREE RUNNING



METRIC FINE											
MM	MM	INSTALLED LENGTH	€	PART #	#	MM	PART #	PART #	PART #	MM	PART #
8.00	1.00	1.5D	12.00MM	47.25	3521-8.00K	20	8.3	3521-8.00I	3500-HIT11	3500-TB12	
10.00	1.25	1.5D	15.00MM	50.40	3521-10.00K	15	10.3	3521-10.00I	3500-HIT13	3500-TB13	
10.00	1.00	1.5D	15.00MM	50.40	3523-10.00K	15	10.3	3523-10.00I	3500-HIT13	3500-TB13	
11.00	1.25	1.5D	16.50MM	61.95	3521-11.00K	10	11.3	3521-11.00I	3500-HIT14	3500-TB14	
11.00	1.00	1.5D	16.50MM	61.95	3523-11.00K	10	11.3	3523-11.00I	3500-HIT14	3500-TB14	
12.00	1.50	1.5D	18.00MM	60.90	3521-12.00K	10	12.4	3521-12.00I	3500-HIT15	3500-TB15	
12.00	1.25	1.5D	18.00MM	60.90	3523-12.00K	10	12.3	3523-12.00I	3500-HIT15	3500-TB15	
12.00	1.00	1.5D	18.00MM	60.90	3524-12.00K	10	12.3	3524-12.00I	3500-HIT15	3500-TB15	
13.00	1.50	1.5D	19.50MM	73.50	3521-13.00K	10	13.2*	3521-13.00I	3500-HIT15	-	
13.00	1.25	1.5D	19.50MM	73.50	3523-13.00K	10	13.2*	3523-13.00I	3500-HIT15	-	
14.00	1.50	1.5D	21.00MM	82.95	3521-14.00K	10	14.4*	3521-14.00I	3500-HIT16	-	
14.00	1.25	1.5D	21.00MM	82.95	3523-14.00K	10	14.3*	3523-14.00I	3500-HIT16	-	
14.00	1.00	1.5D	21.00MM	82.95	3524-14.00K	10	14.3*	3524-14.00I	3500-HIT16	-	
15.00	1.50	1.5D	22.50MM	94.50	3521-15.00K	10	15.3*	3521-15.00I	3500-HIT16	-	
16.00	1.50	1.5D	24.00MM	82.95	3521-16.00K	10	16.5*	3521-16.00I	3500-HIT18	-	
18.00	2.00	1.5D	27.00MM	94.50	3521-18.00K	5	18.5*	3521-18.00I	3500-HIT20	-	
18.00	1.50	1.5D	27.00MM	94.50	3523-18.00K	5	18.5*	3523-18.00I	3500-HIT20	-	
20.00	2.00	1.5D	30.00MM	105.00	3521-20.00K	5	20.5*	3521-20.00I	3500-HIT21	-	
20.00	1.50	1.5D	30.00MM	105.00	3523-20.00K	5	20.5*	3523-20.00I	3500-HIT21	-	
22.00	2.00	1.5D	33.00MM	126.00	3521-22.00K	5	22.5*	3521-22.00I	3500-HIT22	-	
22.00	1.50	1.5D	33.00MM	126.00	3523-22.00K	5	22.5*	3523-22.00I	3500-HIT22	-	
24.00	2.00	1.5D	36.00MM	141.75	3521-24.00K	5	24.5*	3521-24.00I	3500-HIT23	-	
24.00	1.50	1.5D	36.00MM	141.75	3523-24.00K	5	24.5*	3523-24.00I	3500-HIT23	-	
26.00	1.50	1.5D	39.00MM	273.00	3523-26.00K	5	26.5*	3523-26.00I	3500-HIT24	-	
27.00	2.00	1.5D	40.50MM	294.00	3521-27.00K	5	27.5*	3521-27.00I	3500-HIT24	-	
27.00	1.50	1.5D	40.50MM	294.00	3523-27.00K	5	27.5*	3523-27.00I	3500-HIT24	-	
28.00	1.50	1.5D	42.00MM	325.50	3523-28.00K	5	28.5*	3523-28.00I	3500-HIT24	-	
30.00	2.00	1.5D	45.00MM	351.75	3521-30.00K	5	30.5*	3521-30.00I	3500-HIT26	-	
30.00	1.50	1.5D	45.00MM	351.75	3523-30.00K	5	30.5*	3523-30.00I	3500-HIT26	-	
33.00	2.00	1.5D	49.50MM	372.75	3521-33.00K	5	33.5*	3523-33.00I	3500-HIT26	-	
36.00	3.00	1.5D	54.00MM	404.25	3521-36.00K	3	37.0*	3521-36.00I	3500-HIT28	-	
36.00	2.00	1.5D	54.00MM	404.25	3523-36.00K	3	36.5*	3523-36.00I	3500-HIT28	-	
36.00	1.50	1.5D	54.00MM	404.25	3524-36.00K	3	36.5*	3524-36.00I	3500-HIT28	-	

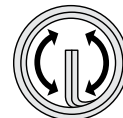

MF

Standard Bolt

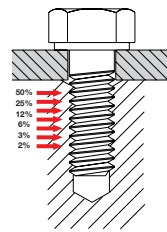

Bolt with PowerCoil insert

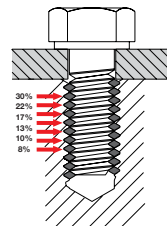

In a conventional threaded joint 75% of the load is placed on the first three threads.

The helical coil design of the PowerCoil Wire Thread Insert allows the shear loading to be transformed into a more desirable radial loading (hoop stress) over the entire length of the insert.

Use of a PowerCoil insert results in a far stronger thread than can be obtained by using conventional drilling or tapping. Improved strength allows designers to select fasteners based on minimum bolt strength and allows the use of smaller diameters and thread lengths - even in magnesium and aluminium alloys.

* Tapping drill not included in thread repair kit.



Some large repair kits over 24mm may be supplied with HIM tools (hex installation mandrels) in place of HIT tools (hand installation tools).



Bulk Free Running Inserts
Page 26



GROUP	PCRK
INSERT TYPE	WIRE THREAD
INSERT MATERIAL	304 STAINLESS STEEL
STYLE	FREE RUNNING

UNC											
INCH	TPI	INSTALLED LENGTH		€	PART #	#	MM	PART #	PART #	PART #	
2G	56	1.5D	0.13"	52.50	3532-2GK	20	2.4	3532-2GI	3500-HIT2	3500-TB2	
3G	48	1.5D	0.15"	52.50	3532-3GK	20	2.7	3532-3GI	3500-HIT3	3500-TB3	
4G	40	1.5D	0.17"	47.25	3532-4GK	20	3.1	3532-4GI	3500-HIT4	3500-TB4	
5G	40	1.5D	0.19"	47.25	3532-5GK	20	3.4	3532-5GI	3500-HIT4	3500-TB4	
6G	32	1.5D	0.21"	46.20	3532-6GK	20	3.8	3532-6GI	3500-HIT5	3500-TB5	
8G	32	1.5D	0.25"	46.20	3532-8GK	20	4.4	3532-8GI	3500-HIT6	3500-TB6	
10G	24	1.5D	0.28"	47.25	3532-10GK	20	5.2	3532-10GI	3500-HIT7	3500-TB8	
12G	24	1.5D	0.33"	47.25	3532-12GK	20	5.8	3532-12GI	3500-HIT8	3500-TB8	
1/4	20	1.5D	0.38"	44.10	3532-1/4K	20	6.7	3532-1/4I	3500-HIT9	3500-TB9	
5/16	18	1.5D	0.47"	51.45	3532-5/16K	20	8.3	3532-5/16I	3500-HIT10	3500-TB12	
3/8	16	1.5D	0.56"	55.65	3532-3/8K	15	9.9	3532-3/8I	3500-HIT13	3500-TB12	
7/16	14	1.5D	0.66"	63.00	3532-7/16K	10	11.6	3532-7/16I	3500-HIT14	3500-TB14	
1/2	13	1.5D	0.75"	67.20	3532-1/2K	10	13.0	3532-1/2I	3500-HIT15	3500-TB15	
9/16	12	1.5D	0.84"	88.20	3532-9/16K	10	15.0*	3532-9/16I	3500-HIT16	-	
5/8	11	1.5D	0.94"	94.50	3532-5/8K	10	16.5*	3532-5/8I	3500-HIT18	-	
3/4	10	1.5D	1.13"	115.50	3532-3/4K	5	19.8*	3532-3/4I	3500-HIT20	-	
7/8	9	1.5D	1.31"	152.25	3532-7/8K	5	23.0*	3532-7/8I	3500-HIT22	-	
1	8	1.5D	1.50"	162.75	3532-1K	5	26.2*	3532-1I	3500-HIT23	-	
1-1/8	7	1.5D	1.69"	325.50	3532-1.1/8K	3	29.5*	3532-1.1/8I	3500-HIT25	-	
1-1/4	7	1.5D	1.88"	351.75	3532-1.1/4K	3	32.5*	3532-1.1/4I	3500-HIT26	-	
1-3/8	6	1.5D	2.06"	414.75	3532-1.3/8K	3	36.0*	3532-1.3/8I	3500-HIT27	-	
1-1/2	6	1.5D	2.25"	446.25	3532-1.1/2K	3	39.5*	3532-1.1/2I	3500-HIT28	-	
UNF											
INCH	TPI	INSTALLED LENGTH		€	PART #	#	MM	PART #	PART #	PART #	
3G	56	1.5D	0.15"	52.50	3534-3GK	20	2.7	3534-3GI	3500-HIT3	3500-TB3	
4G	48	1.5D	0.17"	47.25	3534-4GK	20	3.0	3534-4GI	3500-HIT4	3500-TB4	
6G	40	1.5D	0.21"	46.20	3534-6GK	20	3.8	3534-6GI	3500-HIT5	3500-TB5	
8G	36	1.5D	0.25"	46.20	3534-8GK	20	4.4	3534-8GI	3500-HIT6	3500-TB6	
10G	32	1.5D	0.28"	47.25	3534-10GK	20	5.1	3534-10GI	3500-HIT8	3500-TB8	
12G	28	1.5D	0.33"	47.25	3534-12GK	20	5.6	3534-12GI	3500-HIT8	3500-TB8	
1/4	28	1.5D	0.38"	44.10	3534-1/4K	20	6.7	3534-1/4I	3500-HIT9	3500-TB9	
5/16	24	1.5D	0.47"	51.45	3534-5/16K	20	8.3	3534-5/16I	3500-HIT11	3500-TB12	
3/8	24	1.5D	0.56"	55.65	3534-3/8K	15	9.8	3534-3/8I	3500-HIT13	3500-TB13	
7/16	16	1.5D	0.66"	63.00	3534-7/16-16K	10	11.5	3534-7/16-16I	3500-HIT14	3500-TB14	
7/16	20	1.5D	0.66"	63.00	3534-7/16K	10	11.5	3534-7/16I	3500-HIT14	3500-TB14	
1/2	20	1.5D	0.75"	67.20	3534-1/2K	10	13.0	3534-1/2I	3500-HIT15	3500-TB15	
9/16	18	1.5D	0.84"	88.20	3534-9/16K	10	14.7*	3534-9/16I	3500-HIT16	-	
5/8	18	1.5D	0.94"	94.50	3534-5/8K	10	16.3*	3534-5/8I	3500-HIT18	-	
3/4	16	1.5D	1.13"	115.50	3534-3/4K	5	19.5*	3534-3/4I	3500-HIT21	-	
7/8	14	1.5D	1.31"	152.25	3534-7/8K	5	22.5*	3534-7/8I	3500-HIT22	-	
1	12	1.5D	1.50"	162.75	3534-1K	5	26.0*	3534-1I	3500-HIT23	-	
1	14	1.5D	1.50"	162.75	3535-1K	5	26.0*	3535-1I	3500-HIT23	-	
1-1/8	12	1.5D	1.69"	325.50	3534-1.1/8K	3	29.5*	3534-1.1/8I	3500-HIT25	-	
1-1/4	12	1.5D	1.88"	351.75	3534-1.1/4K	3	32.5*	3534-1.1/4I	3500-HIT26	-	
1-3/8	12	1.5D	2.06"	414.75	3534-1.3/8K	3	35.5*	3534-1.3/8I	3500-HIT27	-	
1-1/2	12	1.5D	2.25"	446.25	3534-1.1/2K	3	38.5*	3534-1.1/2I	3500-HIT28	-	

* Tapping drill not included in thread repair kit.



Some large repair kits over 1" may be supplied with HIM tools (hex installation mandrels) in place of HIT tools (hand installation tools).

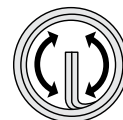

**BSW
BSF
BSP**



GROUP	PCRK
INSERT TYPE	WIRE THREAD
INSERT MATERIAL	304 STAINLESS STEEL
STYLE	FREE RUNNING

BSW										
INCH	TPI	INSTALLED LENGTH		€	PART #	#	MM	PART #	PART #	PART #
1/8	40	1.5D	0.19"	50.40	3528-1/8K	20	3.4	3528-1/8I	3500-HIT4	3500-TB4
3/16	24	1.5D	0.28"	50.40	3528-3/16K	20	5.0	3528-3/16I	3500-HIT7	3500-TB8
1/4	20	1.5D	0.38"	47.25	3528-1/4K	20	6.7	3528-1/4I	3500-HIT9	3500-TB9
5/16	18	1.5D	0.47"	52.50	3528-5/16K	20	8.3	3528-5/16I	3500-HIT10	3500-TB11
3/8	16	1.5D	0.56"	55.65	3528-3/8K	15	9.9	3528-3/8I	3500-HIT11	3500-TB12
7/16	14	1.5D	0.66"	63.00	3528-7/16K	10	11.5	3528-7/16I	3500-HIT14	3500-TB14
1/2	12	1.5D	0.75"	72.45	3528-1/2K	10	13.0	3528-1/2I	3500-HIT15	3500-TB15
9/16	12	1.5D	0.84"	87.15	3528-9/16K	10	14.8*	3528-9/16I	3500-HIT16	-
5/8	11	1.5D	0.94"	94.50	3528-5/8K	10	16.7*	3528-5/8I	3500-HIT18	-
3/4	10	1.5D	1.13"	112.35	3528-3/4K	5	20.0*	3528-3/4I	3500-HIT20	-
7/8	9	1.5D	1.31"	152.25	3528-7/8K	5	23.2*	3528-7/8I	3500-HIT22	-
1	8	1.5D	1.50"	162.75	3528-1K	5	26.5*	3528-1I	3500-HIT23	-

BSF										
INCH	TPI	INSTALLED LENGTH		€	PART #	#	MM	PART #	PART #	PART #
3/16	32	1.5D	0.28"	50.40	3530-3/16K	20	5.0	3530-3/16I	3500-HIT8	3500-TB6
1/4	26	1.5D	0.38"	47.25	3530-1/4K	20	6.6	3530-1/4I	3500-HIT9	3500-TB9
5/16	22	1.5D	0.47"	52.50	3530-5/16K	20	8.3	3530-5/16I	3500-HIT11	3500-TB11
3/8	20	1.5D	0.56"	55.65	3530-3/8K	15	9.9	3530-3/8I	3500-HIT13	3500-TB12
7/16	18	1.5D	0.66"	63.00	3530-7/16K	10	11.5	3530-7/16I	3500-HIT14	3500-TB14
1/2	16	1.5D	0.75"	72.45	3530-1/2K	10	13.0	3530-1/2I	3500-HIT15	3500-TB15
9/16	16	1.5D	0.84"	87.15	3530-9/16K	10	14.8*	3530-9/16I	3500-HIT16	-
5/8	14	1.5D	0.94"	94.50	3530-5/8K	10	16.3*	3530-5/8I	3500-HIT18	-
3/4	12	1.5D	1.13"	112.35	3530-3/4K	5	19.5*	3530-3/4I	3500-HIT20	-
7/8	11	1.5D	1.31"	152.25	3530-7/8K	5	22.8*	3530-7/8I	3500-HIT22	-
1	10	1.5D	1.50"	162.75	3530-1K	5	26.2*	3530-1I	3500-HIT23	-

BSP										
INCH	TPI	INSTALLED LENGTH		€	PART #	#	MM	PART #	PART #	PART #
1/8	28	1.5D	0.19"	86.10	3546-1/8K	10	10.0*	3546-1/8I	3500-HIT14	-
1/4	19	1.5D	0.38"	99.75	3546-1/4K	10	13.6*	3546-1/4I	3500-HIT16	-
3/8	19	1.5D	0.56"	115.50	3546-3/8K	10	17.1*	3546-3/8I	3500-HIT20	-
1/2	14	1.5D	0.75"	148.05	3546-1/2K	10	21.5*	3546-1/2I	3500-HIT23	-
5/8	14	1.5D	0.94"	231.00	3546-5/8K	10	23.4*	3546-5/8I	3500-HIT23	-
3/4	14	1.5D	1.13"	325.50	3546-3/4K	10	27.0*	3546-3/4I	3500-HIT26	-
7/8	14	1.5D	1.31"	283.50	3546-7/8K	5	30.5*	3546-7/8I	3500-HIT27	-
1	11	1.5D	1.50"	367.50	3546-1K	5	33.7*	3546-1I	3500-HIT27	-

* Tapping drill not included in thread repair kit.



Some repair kits may be supplied with HIM tools (hex installation mandrels) in place of HIT tools (hand installation tools).



GROUP	PCRK
INSERT TYPE	WIRE THREAD
INSERT MATERIAL	304 STAINLESS STEEL
STYLE	FREE RUNNING

NPT

INCH	TPI	INSTALLED LENGTH		€	PART #	#	MM	PART #	PART #	PART #
1/16	27	1.5D	0.09"	141.75	3552-1/16K	10	K*	3552-1/16I	3500-HIT10	-
1/8	27	1.5D	0.19"	141.75	3552-1/8K	10	U*	3552-1/8I	3500-HIT13	-
1/4	18	1.5D	0.38"	157.50	3552-1/4K	10	31/64*	3552-1/4I	3500-HIT16	-
3/8	18	1.5D	0.56"	204.75	3552-3/8K	10	5/8*	3552-3/8I	3500-HIT18	-
1/2	14	1.5D	0.75"	278.25	3552-1/2K	10	35/32*	3552-1/2I	3500-HIT22	-
3/4	14	1.5D	1.13"	330.75	3552-3/4K	10	63/64*	3552-3/4I	3500-HIT24	-
1	11.5	1.5D	1.50"	456.75	3552-1K	10	1-1/4*	3552-1I	3500-HIT27	-



Some repair kits may be supplied with HIM tools (hex installation mandrels) in place of HIT tools (hand installation tools).

8-UN

INCH	TPI	INSTALLED LENGTH		€	PART #	#	MM	PART #	PART #	PART #
1-1/8	8	1.5D	1.69"	351.75	3570-1.1/8K	3	28.5*	3570-1.1/8I	3500-HIT25	-
1-1/4	8	1.5D	1.88"	414.75	3570-1.1/4K	3	32.0*	3570-1.1/4I	3500-HIT26	-
1-3/8	8	1.5D	2.06"	509.25	3570-1.3/8K	3	35.0*	3570-1.3/8I	3500-HIT27	-
1-1/2	8	1.5D	2.25"	456.75	3570-1.1/2K	3	38.0*	3570-1.1/2I	3500-HIT28	-
1-5/8	8	1.5D	2.44"	640.50	3570-1.5/8K	3	41.0*	3570-1.5/8I	3500-HIT28	-
1-3/4	8	1.5D	2.63"	651.00	3570-1.3/4K	3	44.5*	3570-1.3/4I	3500-HIT28	-
1-7/8	8	1.5D	2.81"	729.75	3570-1.7/8K	3	47.5*	3570-1.7/8I	3500-HIT30	-
2	8	1.5D	3.00"	813.75	3570-2K	3	50.8*	3570-2I	3500-HIT30	-



Some repair kits may be supplied with HIM tools (hex installation mandrels) in place of HIT tools (hand installation tools).

BSC

INCH	TPI	INSTALLED LENGTH		€	PART #	#	MM	PART #	PART #	PART #
1/4	26	1.5D	0.38"	57.75	3560-1/4K	20	6.6	3560-1/4I	3500-HIT10	3500-TB9
5/16	26	1.5D	0.47"	63.00	3560-5/16K	20	8.0	3560-5/16I	3500-HIT11	3500-TB12
3/8	26	1.5D	0.56"	68.25	3560-3/8K	15	9.8	3560-3/8I	3500-HIT13	3500-TB13
7/16	26	1.5D	0.66"	73.50	3560-7/16K	10	11.1	3560-7/16I	3500-HIT14	3500-TB14
1/2	26	1.5D	0.75"	78.75	3560-1/2K	10	12.7	3560-1/2I	3500-HIT15	3500-TB15

BA

INCH	MM	INCH	INSTALLED LENGTH	€	PART #	#	MM	PART #	PART #	PART #		
0	0.236	6.0	0.0394	1.5D	0.35"	73.50	3544-0K	20	6.2	3544-0I	3500-HIT9	3500-TB11
2	0.185	4.7	0.0319	1.5D	0.28"	70.35	3544-2K	20	4.9	3544-2I	3500-HIT7	3500-TB8
4	0.142	3.6	0.0260	1.5D	0.21"	70.35	3544-4K	20	3.8	3544-4I	3500-HIT5	3500-TB5
6	0.110	2.8	0.0209	1.5D	0.17"	68.25	3544-6K	20	2.9	3544-6I	3500-HIT3	3500-TB3

* Tapping drill not included in thread repair kit.



**MC
MF**

GROUP	PCRK
INSERT TYPE	WIRE THREAD
INSERT MATERIAL	304 STAINLESS STEEL
STYLE	FREE RUNNING

METRIC COARSE M5-M12

MM	MM	INSTALLED LENGTH		€	PART #	#	MM	PART #	PART #	PART #
5.00	0.80	1.5D	7.5MM	257.25	3520-WK1	25	5.2	3520-5.00I	3500-HIT8	3500-TB8
6.00	1.00	1.5D	9.0MM			25	6.3	3520-6.00I	3500-HIT9	3500-TB9
8.00	1.25	1.5D	12.0MM			25	8.3	3520-8.00I	3500-HIT11	3500-TB12
10.00	1.50	1.5D	15.0MM			25	10.4	3520-10.00I	3500-HIT13	3500-TB13
12.00	1.75	1.5D	18.0MM			10	12.4	3520-12.00I	3500-HIT15	3500-TB15

METRIC COARSE M6-M12 + M14 SPARK PLUG

MM	MM	INSTALLED LENGTH		€	PART #	#	MM	PART #	PART #	PART #
6.00	1.00	1.5D	9.0MM	307.65	3522-WK4	25	6.3	3520-6.00I	3500-HIT9	3500-TB9
8.00	1.25	1.5D	12.0MM			25	8.3	3520-8.00I	3500-HIT11	3500-TB12
10.00	1.50	1.5D	15.0MM			25	10.4	3520-10.00I	3500-HIT13	3500-TB13
12.00	1.75	1.5D	18.0MM			10	12.4	3520-12.00I	3500-HIT15	3500-TB15
14.00	1.25	-	8.4MM			5	-	3522-14.00PN	3500-HIT17	-
14.00	1.25	-	12.4MM			5	-	-	-	-
14.00	1.25	-	16.4MM			5	-	-	-	-



SPARK PLUG

MM	MM	INSTALLED LENGTH		€	PART #	#	MM	PART #	PART #	PART #
10.00	1.00	-	0.339"	250.34	3522-WK1	5	-	3520-10.00PN	3500-HIT13	3500-TB13
-	-	-	1/2"			5	-	-	-	-
12.00	1.25	-	1/2"			5	-	3520-10.00PN	3500-HIT15	3500-TB15
-	-	-	3/4"			5	-	-	-	-
14.00	1.25	-	3/8"			5	-	3522-14.00PN	3500-HIT17	-
-	-	-	1/2"			5	-	-	-	-
-	-	-	3/4"			5	-	-	-	-





GROUP	PCRK
INSERT TYPE	WIRE THREAD
INSERT MATERIAL	304 STAINLESS STEEL
STYLE	FREE RUNNING

UNC 1/4" – UNC 1/2"

INCH	TPI	INSTALLED LENGTH		€	PART #	#	MM	PART #	PART #	PART #
1/4	20	1.5D	0.38"	299.25	3532-WK1	25	6.7	3532-1/4I	3500-HIT9	3500-TB9
5/16	18	1.5D	0.47"			25	8.3	3532-5/16I	3500-HIT10	3500-TB12
3/8	16	1.5D	0.56"			25	9.9	3532-3/8I	3500-HIT13	3500-TB12
7/16	14	1.5D	0.66"			10	11.6	3532-7/16I	3500-HIT14	3500-TB14
1/2	13	1.5D	0.75"			10	13.0	3532-1/2I	3500-HIT15	3500-TB15

UNF 1/4" – UNF 1/2"

INCH	TPI	INSTALLED LENGTH		€	PART #	#	MM	PART #	PART #	PART #
1/4	28	1.5D	0.38"	299.25	3534-WK1	25	6.7	3534-1/4I	3500-HIT9	3500-TB9
5/16	24	1.5D	0.47"			25	8.3	3534-5/16I	3500-HIT11	3500-TB12
3/8	24	1.5D	0.56"			25	9.8	3534-3/8I	3500-HIT13	3500-TB13
7/16	20	1.5D	0.66"			10	11.5	3534-7/16I	3500-HIT14	3500-TB14
1/2	20	1.5D	0.75"			10	13.0	3534-1/2I	3500-HIT15	3500-TB15

BSW 1/4" – BSW 1/2"

INCH	TPI	INSTALLED LENGTH		€	PART #	#	MM	PART #	PART #	PART #
1/4	20	1.5D	0.38"	309.75	3528-WK1	25	6.7	3528-1/4I	3500-HIT9	3500-TB9
5/16	18	1.5D	0.47"			25	8.3	3528-5/16I	3500-HIT10	3500-TB11
3/8	16	1.5D	0.56"			25	9.9	3528-3/8I	3500-HIT11	3500-TB12
7/16	14	1.5D	0.66"			10	11.5	3528-7/16I	3500-HIT14	3500-TB14
1/2	12	1.5D	0.75"			10	13.0	3528-1/2I	3500-HIT15	3500-TB15

BSF 1/4" – BSF 1/2"

INCH	TPI	INSTALLED LENGTH		€	PART #	#	MM	PART #	PART #	PART #
1/4	26	1.5D	0.38"	309.75	3530-WK1	25	6.6	3530-1/4I	3500-HIT9	3500-TB9
5/16	22	1.5D	0.47"			25	8.3	3530-5/16I	3500-HIT11	3500-TB11
3/8	20	1.5D	0.56"			25	9.9	3530-3/8I	3500-HIT13	3500-TB12
7/16	18	1.5D	0.66"			10	11.5	3530-7/16I	3500-HIT14	3500-TB14
1/2	16	1.5D	0.75"			10	13.0	3530-1/2I	3500-HIT15	3500-TB15



**UNC
UNF
BSW
BSF**

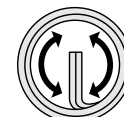

MC

GROUP	PCRP
INSERT TYPE	WIRE THREAD
INSERT MATERIAL	304 STAINLESS STEEL
STYLE	FREE RUNNING

METRIC COARSE										
						1.0D		1.5D		2.0D
MM	MM	INSTALLED LENGTH	#	€	PART #	€	PART #	€	PART #	
2.00	0.40	1.0D	2.00MM	10	2.87	3520-2.00X1.0DP	—	—	—	—
2.00	0.40	1.5D	3.00MM	10	—	—	3.01	3520-2.00X1.5DP	—	—
2.00	0.40	2.0D	4.00MM	10	—	—	—	—	3.15	3520-2.00X2.0DP
2.20	0.45	1.0D	2.20MM	10	2.76	3520-2.20X1.0DP	—	—	—	—
2.20	0.45	1.5D	3.30MM	10	—	—	2.91	3520-2.20X1.5DP	—	—
2.20	0.45	2.0D	4.40MM	10	—	—	—	—	3.03	3520-2.20X2.0DP
2.50	0.45	1.0D	2.50MM	10	2.57	3520-2.50X1.0DP	—	—	—	—
2.50	0.45	1.5D	3.75MM	10	—	—	2.70	3520-2.50X1.5DP	—	—
2.50	0.45	2.0D	5.00MM	10	—	—	—	—	2.81	3520-2.50X2.0DP
3.00	0.50	1.0D	3.00MM	10	2.57	3520-3.00X1.0DP	—	—	—	—
3.00	0.50	1.5D	4.50MM	10	—	—	2.70	3520-3.00X1.5DP	—	—
3.00	0.50	2.0D	6.00MM	10	—	—	—	—	2.81	3520-3.00X2.0DP
3.50	0.60	1.0D	3.50MM	10	2.76	3520-3.50X1.0DP	—	—	—	—
3.50	0.60	1.5D	5.25MM	10	—	—	2.91	3520-3.50X1.5DP	—	—
3.50	0.60	2.0D	7.00MM	10	—	—	—	—	3.03	3520-3.50X2.0DP
4.00	0.70	1.0D	4.00MM	10	2.57	3520-4.00X1.0DP	—	—	—	—
4.00	0.70	1.5D	6.00MM	10	—	—	2.70	3520-4.00X1.5DP	—	—
4.00	0.70	2.0D	8.00MM	10	—	—	—	—	2.81	3520-4.00X2.0DP
5.00	0.80	1.0D	5.00MM	10	2.57	3520-5.00X1.0DP	—	—	—	—
5.00	0.80	1.5D	7.50MM	10	—	—	2.70	3520-5.00X1.5DP	—	—
5.00	0.80	2.0D	10.00MM	10	—	—	—	—	2.81	3520-5.00X2.0DP
6.00	1.00	1.0D	6.00MM	10	2.57	3520-6.00X1.0DP	—	—	—	—
6.00	1.00	1.5D	9.00MM	10	—	—	2.70	3520-6.00X1.5DP	—	—
6.00	1.00	2.0D	12.00MM	10	—	—	—	—	2.81	3520-6.00X2.0DP
7.00	1.00	1.0D	7.00MM	10	2.76	3520-7.00X1.0DP	—	—	—	—
7.00	1.00	1.5D	10.50MM	10	—	—	2.91	3520-7.00X1.5DP	—	—
7.00	1.00	2.0D	14.00MM	10	—	—	—	—	3.03	3520-7.00X2.0DP
8.00	1.25	1.0D	8.00MM	10	2.81	3520-8.00X1.0DP	—	—	—	—
8.00	1.25	1.5D	12.00MM	10	—	—	3.19	3520-8.00X1.5DP	—	—
8.00	1.25	2.0D	16.00MM	10	—	—	—	—	3.75	3520-8.00X2.0DP
9.00	1.25	1.0D	9.00MM	10	3.48	3520-9.00X1.0DP	—	—	—	—
9.00	1.25	1.5D	13.50MM	10	—	—	3.98	3520-9.00X1.5DP	—	—
9.00	1.25	2.0D	18.00MM	10	—	—	—	—	4.70	3520-9.00X2.0DP
10.00	1.50	1.0D	10.00MM	10	3.12	3520-10.00X1.0DP	—	—	—	—
10.00	1.50	1.5D	15.00MM	10	—	—	3.62	3520-10.00X1.5DP	—	—
10.00	1.50	2.0D	20.00MM	10	—	—	—	—	4.62	3520-10.00X2.0DP
11.00	1.50	1.0D	11.00MM	10	3.68	3520-11.00X1.0DP	—	—	—	—
11.00	1.50	1.5D	16.50MM	10	—	—	5.36	3520-11.00X1.5DP	—	—
11.00	1.50	2.0D	22.00MM	10	—	—	—	—	7.04	3520-11.00X2.0DP
12.00	1.75	1.0D	12.00MM	10	3.68	3520-12.00X1.0DP	—	—	—	—
12.00	1.75	1.5D	18.00MM	10	—	—	5.36	3520-12.00X1.5DP	—	—
12.00	1.75	2.0D	24.00MM	10	—	—	—	—	7.04	3520-12.00X2.0DP
13.00	1.75	1.0D	13.00MM	5	3.71	3520-13.00X1.0DP	—	—	—	—
13.00	1.75	1.5D	19.50MM	5	—	—	5.41	3520-13.00X1.5DP	—	—
13.00	1.75	2.0D	26.00MM	5	—	—	—	—	7.09	3520-13.00X2.0DP
14.00	2.00	1.0D	14.00MM	5	3.29	3520-14.00X1.0DP	—	—	—	—
14.00	2.00	1.5D	21.00MM	5	—	—	4.04	3520-14.00X1.5DP	—	—
14.00	2.00	2.0D	28.00MM	5	—	—	—	—	4.97	3520-14.00X2.0DP
15.00	2.00	1.0D	15.00MM	5	4.22	3520-15.00X1.0DP	—	—	—	—
15.00	2.00	1.5D	22.50MM	5	—	—	5.05	3520-15.00X1.5DP	—	—
15.00	2.00	2.0D	30.00MM	5	—	—	—	—	6.17	3520-15.00X2.0DP



GROUP	PCR
INSERT TYPE	WIRE THREAD
INSERT MATERIAL	304 STAINLESS STEEL
STYLE	FREE RUNNING



METRIC COARSE											
MM	MM	INSTALLED LENGTH	#	€	PART #	€	PART #	€	PART #	€	PART #
16.00	2.00	1.0D	16.00MM	5	4.22	3520-16.00X1.0DP	-	-	-	-	-
16.00	2.00	1.5D	24.00MM	5	-	-	5.05	3520-16.00X1.5DP	-	-	-
16.00	2.00	2.0D	32.00MM	5	-	-	-	-	6.17	3520-16.00X2.0DP	-
18.00	2.50	1.0D	18.00MM	5	5.53	3520-18.00X1.0DP	-	-	-	-	-
18.00	2.50	1.5D	27.00MM	5	-	-	7.02	3520-18.00X1.5DP	-	-	-
18.00	2.50	2.0D	36.00MM	5	-	-	-	-	8.41	3520-18.00X2.0DP	-
20.00	2.50	1.0D	20.00MM	5	5.63	3520-20.00X1.0DP	-	-	-	-	-
20.00	2.50	1.5D	30.00MM	5	-	-	7.15	3520-20.00X1.5DP	-	-	-
20.00	2.50	2.0D	40.00MM	5	-	-	-	-	8.56	3520-20.00X2.0DP	-
22.00	2.50	1.0D	22.00MM	3	4.76	3520-22.00X1.0DP	-	-	-	-	-
22.00	2.50	1.5D	33.00MM	3	-	-	5.82	3520-22.00X1.5DP	-	-	-
22.00	2.50	2.0D	44.00MM	3	-	-	-	-	7.03	3520-22.00X2.0DP	-
24.00	3.00	1.0D	24.00MM	3	5.82	3520-24.00X1.0DP	-	-	-	-	-
24.00	3.00	1.5D	36.00MM	3	-	-	7.42	3520-24.00X1.5DP	-	-	-
24.00	3.00	2.0D	48.00MM	3	-	-	-	-	8.90	3520-24.00X2.0DP	-

METRIC COARSE											
MM	MM	INSTALLED LENGTH	#	€	PART #	€	PART #	€	PART #	€	PART #
3.00	0.50	2.5D	7.50MM	10	2.92	3520-3.00X2.5DP	-	-	-	-	-
4.00	0.70	2.5D	10.00MM	10	3.06	3520-4.00X2.5DP	-	-	-	-	-
4.00	0.70	3.0D	12.00MM	10	-	-	3.38	3520-4.00X3.0DP	-	-	-
6.00	1.00	2.5D	15.00MM	10	3.08	3520-6.00X2.5DP	-	-	-	-	-
6.00	1.00	3.0D	18.00MM	10	-	-	3.41	3520-6.00X3.0DP	-	-	-
7.00	1.00	3.0D	21.00MM	10	-	-	6.78	3520-7.00X3.0DP	-	-	-
8.00	1.25	2.5D	20.00MM	10	4.50	3520-8.00X2.5DP	-	-	-	-	-
8.00	1.25	3.0D	24.00MM	10	-	-	5.18	3520-8.00X3.0DP	-	-	-
9.00	1.25	3.0D	27.00MM	10	-	-	6.78	3520-9.00X3.0DP	-	-	-
10.00	1.50	2.5D	25.00MM	10	5.61	3520-10.00X2.5DP	-	-	-	-	-
10.00	1.50	3.0D	30.00MM	10	-	-	6.60	3520-10.00X3.0DP	-	-	-
12.00	1.75	2.5D	30.00MM	10	9.27	3520-12.00X2.5DP	-	-	-	-	-
12.00	1.75	3.0D	36.00MM	10	-	-	11.33	3520-12.00X3.0DP	-	-	-
14.00	2.00	2.5D	35.00MM	5	5.98	3520-14.00X2.5DP	-	-	-	-	-
14.00	2.00	3.0D	42.00MM	5	-	-	6.84	3520-14.00X3.0DP	-	-	-
16.00	2.00	2.5D	40.00MM	5	7.23	3520-16.00X2.5DP	-	-	-	-	-
24.00	3.00	2.5D	60.00MM	3	13.65	3520-24.00X2.5DP	-	-	-	-	-

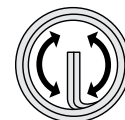









MF

GROUP	PCRP
INSERT TYPE	WIRE THREAD
INSERT MATERIAL	304 STAINLESS STEEL
STYLE	FREE RUNNING

METRIC FINE										
MM	MM	INSTALLED LENGTH	#	€	PART #	€	PART #	€	PART #	€
6.00	0.75	1.0D	6.00	10	2.47	3521-6.00X1.0DP	-	-	-	-
6.00	0.75	1.5D	9.00	10	-	-	2.71	3521-6.00X1.5DP	-	-
6.00	0.75	2.0D	12.00	10	-	-	-	-	2.86	3521-6.00X2.0DP
8.00	1.00	1.0D	8.00	10	2.81	3521-8.00X1.0DP	-	-	-	-
8.00	1.00	1.5D	12.00	10	-	-	3.19	3521-8.00X1.5DP	-	-
8.00	1.00	2.0D	16.00	10	-	-	-	-	3.75	3521-8.00X2.0DP
8.00	0.75	1.0D	8.00	10	3.68	3523-8.00X1.0DP	-	-	-	-
8.00	0.75	1.5D	12.00	10	-	-	4.16	3523-8.00X1.5DP	-	-
8.00	0.75	2.0D	16.00	10	-	-	-	-	4.74	3523-8.00X2.0DP
9.00	1.00	1.0D	9.00	10	3.68	3521-9.00X1.0DP	-	-	-	-
9.00	1.00	1.5D	13.50	10	-	-	4.16	3521-9.00X1.5DP	-	-
9.00	1.00	2.0D	18.00	10	-	-	-	-	4.74	3521-9.00X2.0DP
10.00	1.25	1.0D	10.00	10	3.12	3521-10.00X1.0DP	-	-	-	-
10.00	1.25	1.5D	15.00	10	-	-	3.62	3521-10.00X1.5DP	-	-
10.00	1.25	2.0D	20.00	10	-	-	-	-	4.62	3521-10.00X2.0DP
10.00	1.00	1.0D	10.00	10	3.12	3523-10.00X1.0DP	-	-	-	-
10.00	1.00	1.5D	15.00	10	-	-	3.62	3523-10.00X1.5DP	-	-
10.00	1.00	2.0D	20.00	10	-	-	-	-	4.62	3523-10.00X2.0DP
11.00	1.25	1.0D	11.00	10	3.68	3521-11.00X1.0DP	-	-	-	-
11.00	1.25	1.5D	16.50	10	-	-	5.36	3521-11.00X1.5DP	-	-
11.00	1.25	2.0D	22.00	10	-	-	-	-	7.04	3521-11.00X2.0DP
11.00	1.00	1.0D	11.00	10	3.68	3523-11.00X1.0DP	-	-	-	-
11.00	1.00	1.5D	16.50	10	-	-	5.36	3523-11.00X1.5DP	-	-
11.00	1.00	2.0D	22.00	10	-	-	-	-	7.04	3523-11.00X2.0DP
12.00	1.50	1.0D	12.00	10	3.68	3521-12.00X1.0DP	-	-	-	-
12.00	1.50	1.5D	18.00	10	-	-	5.36	3521-12.00X1.5DP	-	-
12.00	1.50	2.0D	24.00	10	-	-	-	-	7.04	3521-12.00X2.0DP
12.00	1.25	1.0D	12.00	10	3.68	3523-12.00X1.0DP	-	-	-	-
12.00	1.25	1.5D	18.00	10	-	-	5.36	3523-12.00X1.5DP	-	-
12.00	1.25	2.0D	24.00	10	-	-	-	-	7.04	3523-12.00X2.0DP
12.00	1.00	1.0D	12.00	10	4.84	3524-12.00X1.0DP	-	-	-	-
12.00	1.00	1.5D	18.00	10	-	-	7.14	3524-12.00X1.5DP	-	-
12.00	1.00	2.0D	24.00	10	-	-	-	-	9.44	3524-12.00X2.0DP
13.00	1.50	1.0D	13.00	5	5.38	3521-13.00X1.0DP	-	-	-	-
13.00	1.50	1.5D	19.50	5	-	-	6.89	3521-13.00X1.5DP	-	-
13.00	1.50	2.0D	26.00	5	-	-	-	-	8.62	3521-13.00X2.0DP
13.00	1.25	1.0D	13.00	5	5.38	3523-13.00X1.0DP	-	-	-	-
13.00	1.25	1.5D	19.50	5	-	-	6.89	3523-13.00X1.5DP	-	-
13.00	1.25	2.0D	26.00	5	-	-	-	-	8.62	3523-13.00X2.0DP
14.00	1.50	1.0D	14.00	5	3.29	3521-14.00X1.0DP	-	-	-	-
14.00	1.50	1.5D	21.00	5	-	-	4.04	3521-14.00X1.5DP	-	-
14.00	1.50	2.0D	28.00	5	-	-	-	-	4.97	3521-14.00X2.0DP
14.00	1.25	1.0D	14.00	5	3.46	3523-14.00X1.0DP	-	-	-	-
14.00	1.25	1.5D	21.00	5	-	-	3.73	3523-14.00X1.5DP	-	-
14.00	1.25	2.0D	28.00	5	-	-	-	-	4.07	3523-14.00X2.0DP
14.00	1.00	1.0D	14.00	5	3.86	3524-14.00X1.0DP	-	-	-	-
14.00	1.00	1.5D	21.00	5	-	-	4.71	3524-14.00X1.5DP	-	-
14.00	1.00	2.0D	28.00	5	-	-	-	-	5.29	3524-14.00X2.0DP
15.00	1.50	1.0D	15.00	5	4.60	3521-15.00X1.0DP	-	-	-	-
15.00	1.50	1.5D	22.50	5	-	-	5.67	3521-15.00X1.5DP	-	-
15.00	1.50	2.0D	30.00	5	-	-	-	-	7.26	3521-15.00X2.0DP



GROUP	PCRIP
INSERT TYPE	WIRE THREAD
INSERT MATERIAL	304 STAINLESS STEEL
STYLE	FREE RUNNING

METRIC FINE											
 MF						1.0D		1.5D		2.0D	
	MM	MM	INSTALLED LENGTH	#	€	PART #	€	PART #	€	PART #	
16.00	1.50	1.0D	16.00MM	5	4.22	3521-16.00X1.0DP	-	-	-	-	-
16.00	1.50	1.5D	24.00MM	5	-	-	5.05	3521-16.00X1.5DP	-	-	-
16.00	1.50	2.0D	32.00MM	5	-	-	-	-	6.17	3521-16.00X2.0DP	
18.00	2.00	1.0D	18.00MM	5	5.53	3521-18.00X1.0DP	-	-	-	-	-
18.00	2.00	1.5D	27.00MM	5	-	-	7.02	3521-18.00X1.5DP	-	-	-
18.00	2.00	2.0D	36.00MM	5	-	-	-	-	8.41	3521-18.00X2.0DP	
18.00	1.50	1.0D	18.00MM	5	5.53	3523-18.00X1.0DP	-	-	-	-	-
18.00	1.50	1.5D	27.00MM	5	-	-	7.02	3523-18.00X1.5DP	-	-	-
18.00	1.50	2.0D	36.00MM	5	-	-	-	-	8.41	3523-18.00X2.0DP	
20.00	2.00	1.0D	20.00MM	5	5.63	3521-20.00X1.0DP	-	-	-	-	-
20.00	2.00	1.5D	30.00MM	5	-	-	7.15	3521-20.00X1.5DP	-	-	-
20.00	2.00	2.0D	40.00MM	5	-	-	-	-	8.56	3521-20.00X2.0DP	
20.00	1.50	1.0D	20.00MM	5	5.63	3523-20.00X1.0DP	-	-	-	-	-
20.00	1.50	1.5D	30.00MM	5	-	-	7.15	3523-20.00X1.5DP	-	-	-
20.00	1.50	2.0D	40.00MM	5	-	-	-	-	8.56	3523-20.00X2.0DP	
20.00	1.25	1.5D	30.00MM	5	-	-	13.32	3524-20.00X1.5DP	-	-	-
22.00	2.00	1.0D	22.00MM	3	4.76	3521-22.00X1.0DP	-	-	-	-	-
22.00	2.00	1.5D	33.00MM	3	-	-	5.83	3521-22.00X1.5DP	-	-	-
22.00	2.00	2.0D	44.00MM	3	-	-	-	-	7.03	3521-22.00X2.0DP	
22.00	1.50	1.0D	22.00MM	3	4.76	3523-22.00X1.0DP	-	-	-	-	-
22.00	1.50	1.5D	33.00MM	3	-	-	5.83	3523-22.00X1.5DP	-	-	-
22.00	1.50	2.0D	44.00MM	3	-	-	-	-	7.03	3523-22.00X2.0DP	
24.00	2.00	1.0D	24.00MM	3	5.83	3521-24.00X1.0DP	-	-	-	-	-
24.00	2.00	1.5D	36.00MM	3	-	-	7.42	3521-24.00X1.5DP	-	-	-
24.00	2.00	2.0D	48.00MM	3	-	-	-	-	8.90	3521-24.00X2.0DP	
24.00	1.50	1.0D	24.00MM	3	5.83	3523-24.00X1.0DP	-	-	-	-	-
24.00	1.50	1.5D	36.00MM	3	-	-	7.42	3523-24.00X1.5DP	-	-	-
24.00	1.50	2.0D	48.00MM	3	-	-	-	-	8.90	3523-24.00X2.0DP	



GROUP	PCRP
INSERT TYPE	WIRE THREAD
INSERT MATERIAL	304 STAINLESS STEEL
STYLE	FREE RUNNING

SPARK PLUG										
					€	PART #	€	PART #	€	PART #
10.00	1.00	0.339"	10	0.339"	3.12	3522-10.00X.339P	-	-	-	-
10.00	1.00	1/2"	10	1/2"	-	-	3.68	3522-10.00X1/2P	-	-
12.00	1.25	1/2"	10	1/2"	-	-	3.68	3522-12.00X1/2P	-	-
12.00	1.25	3/4"	10	3/4"	-	-	-	-	5.36	3522-12.00X3/4P
18.00	1.25	1/2"	10	1/2"	-	-	4.06	3522-18.00X1/2P	-	-



SPARK PLUG												
					€	PART #	€	PART #	€	PART #	€	PART #
14.00	1.25	3/8"	10	3/8"	4.01	3522-14.00X3/8P	-	-	-	-	-	-
14.00	1.25	7/16"	10	7/16"	-	-	5.77	3522-14.00X7/16P	-	-	-	-
14.00	1.25	1/2"	10	1/2"	-	-	-	-	5.77	3522-14.00X1/2P	-	-
14.00	1.25	3/4"	10	3/4"	-	-	-	-	-	-	8.46	3522-14.00X3/4P

SPARK PLUG										
					€	PART #	€	PART #	€	PART #
14	1.25	8.4MM	10	8.4MM	2.30	3522-14.00X8.4P	-	-	-	-
14	1.25	12.4MM	10	12.4MM	-	-	3.17	3522-14.00X12.4P	-	-
14	1.25	16.4MM	10	16.4MM	-	-	-	-	4.52	3522-14.00X16.4P



GROUP	PCRP
INSERT TYPE	WIRE THREAD
INSERT MATERIAL	304 STAINLESS STEEL
STYLE	FREE RUNNING

UNC											
INCH	TPI	INSTALLED LENGTH	#	€	PART #	€	PART #	€	PART #		
2G	56	1.0D	0.09"	10	3.24	3532-2GX1.0DP	-	-	-	-	-
2G	56	1.5D	0.13"	10	-	-	3.41	3532-2GX1.5DP	-	-	-
2G	56	2.0D	0.17"	10	-	-	-	-	3.56	3532-2GX2.0DP	-
3G	48	1.0D	0.10"	10	4.84	3532-3GX1.0DP	-	-	-	-	-
3G	48	1.5D	0.15"	10	-	-	5.23	3532-3GX1.5DP	-	-	-
3G	48	2.0D	0.20"	10	-	-	-	-	5.52	3532-3GX2.0DP	-
4G	40	1.0D	0.11"	10	2.67	3532-4GX1.0DP	-	-	-	-	-
4G	40	1.5D	0.17"	10	-	-	2.80	3532-4GX1.5DP	-	-	-
4G	40	2.0D	0.22"	10	-	-	-	-	2.92	3532-4GX2.0DP	-
5G	40	1.0D	0.13"	10	2.87	3532-5GX1.0DP	-	-	-	-	-
5G	40	1.5D	0.19"	10	-	-	3.03	3532-5GX1.5DP	-	-	-
5G	40	2.0D	0.25"	10	-	-	-	-	3.15	3532-5GX2.0DP	-
6G	32	1.0D	0.14"	10	2.67	3532-6GX1.0DP	-	-	-	-	-
6G	32	1.5D	0.21"	10	-	-	2.80	3532-6GX1.5DP	-	-	-
6G	32	2.0D	0.28"	10	-	-	-	-	2.92	3532-6GX2.0DP	-
8G	32	1.0D	0.16"	10	2.67	3532-8GX1.0DP	-	-	-	-	-
8G	32	1.5D	0.25"	10	-	-	2.80	3532-8GX1.5DP	-	-	-
8G	32	2.0D	0.33"	10	-	-	-	-	2.92	3532-8GX2.0DP	-
10G	24	1.0D	0.19"	10	2.67	3532-10GX1.0DP	-	-	-	-	-
10G	24	1.5D	0.29"	10	-	-	2.80	3532-10GX1.5DP	-	-	-
10G	24	2.0D	0.38"	10	-	-	-	-	2.92	3532-10GX2.0DP	-
12G	24	1.0D	0.22"	10	2.87	3532-12GX1.0DP	-	-	-	-	-
12G	24	1.5D	0.32"	10	-	-	3.03	3532-12GX1.5DP	-	-	-
12G	24	2.0D	0.43"	10	-	-	-	-	3.15	3532-12GX2.0DP	-
1/4	20	1.0D	0.25"	10	2.67	3532-1/4X1.0DP	-	-	-	-	-
1/4	20	1.5D	0.38"	10	-	-	2.80	3532-1/4X1.5DP	-	-	-
1/4	20	2.0D	0.50"	10	-	-	-	-	2.92	3532-1/4X2.0DP	-
5/16	18	1.0D	0.31"	10	2.92	3532-5/16X1.0DP	-	-	-	-	-
5/16	18	1.5D	0.47"	10	-	-	3.32	3532-5/16X1.5DP	-	-	-
5/16	18	2.0D	0.63"	10	-	-	-	-	3.91	3532-5/16X2.0DP	-
3/8	16	1.0D	0.38"	10	3.25	3532-3/8X1.0DP	-	-	-	-	-
3/8	16	1.5D	0.56"	10	-	-	3.77	3532-3/8X1.5DP	-	-	-
3/8	16	2.0D	0.75"	10	-	-	-	-	4.82	3532-3/8X2.0DP	-
7/16	14	1.0D	0.44"	10	3.63	3532-7/16X1.0DP	-	-	-	-	-
7/16	14	1.5D	0.66"	10	-	-	4.29	3532-7/16X1.5DP	-	-	-
7/16	14	2.0D	0.88"	10	-	-	-	-	5.60	3532-7/16X2.0DP	-
1/2	13	1.0D	0.50"	10	3.84	3532-1/2X1.0DP	-	-	-	-	-
1/2	13	1.5D	0.75"	10	-	-	5.60	3532-1/2X1.5DP	-	-	-
1/2	13	2.0D	1.00"	10	-	-	-	-	7.36	3532-1/2X2.0DP	-
9/16	12	1.0D	0.56"	5	3.29	3532-9/16X1.0DP	-	-	-	-	-
9/16	12	1.5D	0.84"	5	-	-	4.04	3532-9/16X1.5DP	-	-	-
9/16	12	2.0D	1.13"	5	-	-	-	-	4.97	3532-9/16X2.0DP	-
5/8	11	1.0D	0.63"	5	4.22	3532-5/8X1.0DP	-	-	-	-	-
5/8	11	1.5D	0.94"	5	-	-	5.05	3532-5/8X1.5DP	-	-	-
5/8	11	2.0D	1.25"	5	-	-	-	-	6.17	3532-5/8X2.0DP	-
3/4	10	1.0D	0.75"	5	5.53	3532-3/4X1.0DP	-	-	-	-	-
3/4	10	1.5D	1.13"	5	-	-	7.02	3532-3/4X1.5DP	-	-	-
3/4	10	2.0D	1.50"	5	-	-	-	-	8.41	3532-3/4X2.0DP	-
7/8	9	1.0D	0.88"	3	4.67	3532-7/8X1.0DP	-	-	-	-	-
7/8	9	1.5D	1.31"	3	-	-	5.72	3532-7/8X1.5DP	-	-	-
7/8	9	2.0D	1.75"	3	-	-	-	-	6.90	3532-7/8X2.0DP	-
1	8	1.0D	1.00"	3	5.72	3532-1X1.0DP	-	-	-	-	-
1	8	1.5D	1.50"	3	-	-	7.29	3532-1X1.5DP	-	-	-
1	8	2.0D	2.00"	3	-	-	-	-	8.74	3532-1X2.0DP	-



GROUP	PCRP
INSERT TYPE	WIRE THREAD
INSERT MATERIAL	304 STAINLESS STEEL
STYLE	FREE RUNNING

UNF										
INCH	TPI	INSTALLED LENGTH		#	€	PART #	€	PART #	€	PART #
3G	56	1.0D	0.10"	10	4.84	3534-3GX1.0DP	-	-	-	-
3G	56	1.5D	0.15"	10	-	-	5.23	3534-3GX1.5DP	-	-
3G	56	2.0D	0.20"	10	-	-	-	-	5.52	3534-3GX2.0DP
4G	48	1.0D	0.11"	10	2.67	3534-4GX1.0DP	-	-	-	-
4G	48	1.5D	0.17"	10	-	-	2.80	3534-4GX1.5DP	-	-
4G	48	2.0D	0.22"	10	-	-	-	-	2.92	3534-4GX2.0DP
6G	40	1.0D	0.14"	10	2.67	3534-6GX1.0DP	-	-	-	-
6G	40	1.5D	0.21"	10	-	-	2.80	3534-6GX1.5DP	-	-
6G	40	2.0D	0.28"	10	-	-	-	-	2.92	3534-6GX2.0DP
8G	36	1.0D	0.16"	10	2.67	3534-8GX1.0DP	-	-	-	-
8G	36	1.5D	0.25"	10	-	-	2.80	3534-8GX1.5DP	-	-
8G	36	2.0D	0.33"	10	-	-	-	-	2.92	3534-8GX2.0DP
10G	32	1.0D	0.19"	10	2.67	3534-10GX1.0DP	-	-	-	-
10G	32	1.5D	0.29"	10	-	-	2.80	3534-10GX1.5DP	-	-
10G	32	2.0D	0.38"	10	-	-	-	-	2.92	3534-10GX2.0DP
12G	28	1.0D	0.22"	10	2.57	3534-12GX1.0DP	-	-	-	-
12G	28	1.5D	0.32"	10	-	-	2.67	3534-12GX1.5DP	-	-
12G	28	2.0D	0.43"	10	-	-	-	-	3.00	3534-12GX2.0DP
1/4	32	1.5D	0.38"	10	-	-	3.26	3535-1/4X1.5DP	-	-
1/4	28	1.0D	0.25"	10	2.67	3534-1/4X1.0DP	-	-	-	-
1/4	28	1.5D	0.38"	10	-	-	2.80	3534-1/4X1.5DP	-	-
1/4	28	2.0D	0.50"	10	-	-	-	-	2.92	3534-1/4X2.0DP
1/4	24	1.0D	0.25"	10	2.67	3534-1/4X1.0DP	-	-	-	-
1/4	24	1.5D	0.38"	10	-	-	2.80	3534-1/4X1.5DP	-	-
1/4	24	2.0D	0.50"	10	-	-	-	-	2.92	3534-1/4X2.0DP
5/16	24	1.0D	0.31"	10	2.92	3534-5/16X1.0DP	-	-	-	-
5/16	24	1.5D	0.47"	10	-	-	3.32	3534-5/16X1.5DP	-	-
5/16	24	2.0D	0.62"	10	-	-	-	-	3.91	3534-5/16X2.0DP
3/8	24	1.0D	0.38"	10	3.25	3534-3/8X1.0DP	-	-	-	-
3/8	24	1.5D	0.57"	10	-	-	3.77	3534-3/8X1.5DP	-	-
3/8	24	2.0D	0.76"	10	-	-	-	-	4.82	3534-3/8X2.0DP
7/16	20	1.0D	0.44"	10	3.64	3534-7/16X1.0DP	-	-	-	-
7/16	20	1.5D	0.66"	10	-	-	4.30	3534-7/16X1.5DP	-	-
7/16	20	2.0D	0.88"	10	-	-	-	-	5.60	3534-7/16X2.0DP
7/16	16	1.5D	0.66"	10	-	-	4.30	3534-7/16X1.5DP	-	-
1/2	20	1.0D	0.50"	10	3.84	3534-1/2X1.0DP	-	-	-	-
1/2	20	1.5D	0.75"	10	-	-	5.60	3534-1/2X1.5DP	-	-
1/2	20	2.0D	1.00"	10	-	-	-	-	7.37	3534-1/2X2.0DP
9/16	18	1.0D	0.56"	5	3.29	3534-9/16X1.0DP	-	-	-	-
9/16	18	1.5D	0.84"	5	-	-	4.04	3534-9/16X1.5DP	-	-
9/16	18	2.0D	1.12"	5	-	-	-	-	4.97	3534-9/16X2.0DP
5/8	18	1.0D	0.63"	5	4.22	3534-5/8X1.0DP	-	-	-	-
5/8	18	1.5D	0.95"	5	-	-	5.05	3534-5/8X1.5DP	-	-
5/8	18	2.0D	1.26"	5	-	-	-	-	6.17	3534-5/8X2.0DP
3/4	16	1.0D	0.75"	5	5.53	3534-3/4X1.0DP	-	-	-	-
3/4	16	1.5D	1.13"	5	-	-	7.02	3534-3/4X1.5DP	-	-
3/4	16	2.0D	1.50"	5	-	-	-	-	8.41	3534-3/4X2.0DP
7/8	14	1.0D	0.88"	3	6.32	3534-7/8X1.0DP	-	-	-	-
7/8	14	1.5D	1.32"	3	-	-	6.90	3534-7/8X1.5DP	-	-
7/8	14	2.0D	1.76"	3	-	-	-	-	7.92	3534-7/8X2.0DP
1	14	1.0D	1.00"	3	8.57	3535-1X1.0DP	-	-	-	-
1	14	1.5D	1.50"	3	-	-	8.18	3535-1X1.5DP	-	-
1	14	2.0D	2.00"	3	-	-	-	-	11.33	3535-1X2.0DP
1	12	1.0D	1.00"	3	7.14	3534-1X1.0DP	-	-	-	-
1	12	1.5D	1.50"	3	-	-	8.18	3534-1X1.5DP	-	-
1	12	2.0D	2.00"	3	-	-	-	-	9.21	3534-1X2.0DP



GROUP	PCRIP
INSERT TYPE	WIRE THREAD
INSERT MATERIAL	304 STAINLESS STEEL
STYLE	FREE RUNNING

BSW											
INCH	TPI	INSTALLED LENGTH	#	€	PART #	€	PART #	€	PART #		
1/8	40	1.0D	0.13"	10	2.87	3528-1/8X1.0DP	-	-	-	-	-
1/8	40	1.5D	0.20"	10	-	-	3.03	3528-1/8X1.5DP	-	-	-
1/8	40	2.0D	0.26"	10	-	-	-	-	3.15	3528-1/8X2.0DP	-
3/16	24	1.0D	0.19"	10	2.67	3528-3/16X1.0DP	-	-	-	-	-
3/16	24	1.5D	0.29"	10	-	-	2.80	3528-3/16X1.5DP	-	-	-
3/16	24	2.0D	0.38"	10	-	-	-	-	2.92	3528-3/16X2.0DP	-
1/4	20	1.0D	0.25"	10	2.67	3528-1/4X1.0DP	-	-	-	-	-
1/4	20	1.5D	0.38"	10	-	-	2.80	3528-1/4X1.5DP	-	-	-
1/4	20	2.0D	0.50"	10	-	-	-	-	2.92	3528-1/4X2.0DP	-
5/16	18	1.0D	0.31"	10	2.92	3528-5/16X1.0DP	-	-	-	-	-
5/16	18	1.5D	0.47"	10	-	-	3.32	3528-5/16X1.5DP	-	-	-
5/16	18	2.0D	0.62"	10	-	-	-	-	3.91	3528-5/16X2.0DP	-
3/8	16	1.0D	0.38"	10	3.25	3528-3/8X1.0DP	-	-	-	-	-
3/8	16	1.5D	0.57"	10	-	-	3.77	3528-3/8X1.5DP	-	-	-
3/8	16	2.0D	0.76"	10	-	-	-	-	4.82	3528-3/8X2.0DP	-
7/16	14	1.0D	0.44"	10	3.64	3528-7/16X1.0DP	-	-	-	-	-
7/16	14	1.5D	0.66"	10	-	-	4.30	3528-7/16X1.5DP	-	-	-
7/16	14	2.0D	0.88"	10	-	-	-	-	5.60	3528-7/16X2.0DP	-
1/2	12	1.0D	0.50"	10	3.84	3528-1/2X1.0DP	-	-	-	-	-
1/2	12	1.5D	0.75"	10	-	-	5.60	3528-1/2X1.5DP	-	-	-
1/2	12	2.0D	1.00"	10	-	-	-	-	7.37	3528-1/2X2.0DP	-
9/16	12	1.0D	0.56"	5	3.90	3528-9/16X1.0DP	-	-	-	-	-
9/16	12	1.5D	0.84"	5	-	-	4.82	3528-9/16X1.5DP	-	-	-
9/16	12	2.0D	1.12"	5	-	-	-	-	5.96	3528-9/16X2.0DP	-
5/8	11	1.0D	0.63"	5	5.04	3528-5/8X1.0DP	-	-	-	-	-
5/8	11	1.5D	0.95"	5	-	-	6.06	3528-5/8X1.5DP	-	-	-
5/8	11	2.0D	1.26"	5	-	-	-	-	7.42	3528-5/8X2.0DP	-
3/4	10	1.0D	0.75"	5	6.64	3528-3/4X1.0DP	-	-	-	-	-
3/4	10	1.5D	1.13"	5	-	-	8.47	3528-3/4X1.5DP	-	-	-
3/4	10	2.0D	1.50"	5	-	-	-	-	10.17	3528-3/4X2.0DP	-
7/8	9	1.0D	0.88"	3	4.58	3528-7/8X1.0DP	-	-	-	-	-
7/8	9	1.5D	1.32"	3	-	-	5.62	3528-7/8X1.5DP	-	-	-
7/8	9	2.0D	1.76"	3	-	-	-	-	6.78	3528-7/8X2.0DP	-
1	8	1.0D	1.00"	3	5.62	3528-1X1.0DP	-	-	-	-	-
1	8	1.5D	1.50"	3	-	-	7.15	3528-1X1.5DP	-	-	-
1	8	2.0D	2.00"	3	-	-	-	-	8.58	3528-1X2.0DP	-



GROUP	PCRP
INSERT TYPE	WIRE THREAD
INSERT MATERIAL	304 STAINLESS STEEL
STYLE	FREE RUNNING

BSF										
					1.0D		1.5D		2.0D	
INCH	TPI	INSTALLED LENGTH		#	€	PART #	€	PART #	€	PART #
3/16	32	1.0D	0.19"	10	2.67	3530-3/16X1.0DP	–	–	–	–
3/16	32	1.5D	0.29"	10	–	–	2.80	3530-3/16X1.5DP	–	–
3/16	32	2.0D	0.38"	10	–	–	–	–	2.92	3530-3/16X2.0DP
1/4	26	1.0D	0.25"	10	2.67	3530-1/4X1.0DP	–	–	–	–
1/4	26	1.5D	0.38"	10	–	–	2.80	3530-1/4X1.5DP	–	–
1/4	26	2.0D	0.50"	10	–	–	–	–	2.92	3530-1/4X2.0DP
5/16	22	1.0D	0.31"	10	2.92	3530-5/16X1.0DP	–	–	–	–
5/16	22	1.5D	0.47"	10	–	–	3.32	3530-5/16X1.5DP	–	–
5/16	22	2.0D	0.62"	10	–	–	–	–	3.91	3530-5/16X2.0DP
3/8	20	1.0D	0.38"	10	3.25	3530-3/8X1.0DP	–	–	–	–
3/8	20	1.5D	0.57"	10	–	–	3.77	3530-3/8X1.5DP	–	–
3/8	20	2.0D	0.76"	10	–	–	–	–	4.82	3530-3/8X2.0DP
7/16	18	1.0D	0.44"	10	3.64	3530-7/16X1.0DP	–	–	–	–
7/16	18	1.5D	0.66"	10	–	–	4.30	3530-7/16X1.5DP	–	–
7/16	18	2.0D	0.88"	10	–	–	–	–	5.60	3530-7/16X2.0DP
1/2	16	1.0D	0.50"	10	3.84	3530-1/2X1.0DP	–	–	–	–
1/2	16	1.5D	0.75"	10	–	–	5.60	3530-1/2X1.5DP	–	–
1/2	16	2.0D	1.00"	10	–	–	–	–	7.37	3530-1/2X2.0DP
9/16	16	1.0D	0.56"	5	4.10	3530-9/16X1.0DP	–	–	–	–
9/16	16	1.5D	0.84"	5	–	–	4.68	3530-9/16X1.5DP	–	–
9/16	16	2.0D	1.12"	5	–	–	–	–	6.73	3530-9/16X2.0DP
5/8	14	1.0D	0.63"	5	5.50	3530-5/8X1.0DP	–	–	–	–
5/8	14	1.5D	0.95"	5	–	–	7.02	3530-5/8X1.5DP	–	–
5/8	14	2.0D	1.26"	5	–	–	–	–	8.78	3530-5/8X2.0DP
3/4	12	1.0D	0.75"	5	7.90	3530-3/4X1.0DP	–	–	–	–
3/4	12	1.5D	1.13"	5	–	–	9.36	3530-3/4X1.5DP	–	–
3/4	12	2.0D	1.50"	5	–	–	–	–	12.28	3530-3/4X2.0DP
7/8	11	1.0D	0.88"	3	8.08	3530-7/8X1.0DP	–	–	–	–
7/8	11	1.5D	1.32"	3	–	–	9.48	3530-7/8X1.5DP	–	–
7/8	11	2.0D	1.76"	3	–	–	–	–	10.88	3530-7/8X2.0DP
1	10	1.0D	1.00"	3	10.53	3530-1X1.0DP	–	–	–	–
1	10	1.5D	1.50"	3	–	–	11.93	3530-1X1.5DP	–	–
1	10	2.0D	2.00"	3	–	–	–	–	13.69	3530-1X2.0DP



GROUP	PCRP
INSERT TYPE	WIRE THREAD
INSERT MATERIAL	304 STAINLESS STEEL
STYLE	FREE RUNNING



**BSC
BSP
NPT**

BSC											
INCH	TPI	INSTALLED LENGTH	#	€	PART #	€	PART #	€	PART #	€	PART #
1/4	26	1.5D 0.38"	10	-	-	4.28	3560-1/4X1.5DP	-	-	-	-
5/16	26	1.5D 0.47"	10	-	-	5.58	3560-5/16X1.5DP	-	-	-	-
3/8	26	1.5D 0.56"	10	-	-	6.48	3560-3/8X1.5DP	-	-	-	-
7/16	26	1.5D 0.66"	10	-	-	9.00	3560-7/16X1.5DP	-	-	-	-
1/2	26	1.5D 0.75"	10	-	-	14.40	3560-1/2X1.5DP	-	-	-	-



BSP											
INCH	TPI	INSTALLED LENGTH	#	€	PART #	€	PART #	€	PART #	€	PART #
1/8	28	1.5D 0.19"	10	-	-	6.17	3546-1/8X1.5DP	-	-	-	-
1/4	19	1.5D 0.38"	10	-	-	8.64	3546-1/4X1.5DP	-	-	-	-
1/4	19	2.0D 0.50"	10	-	-	-	-	12.41	3546-1/4X2.0DP	-	
3/8	19	1.5D 0.56"	10	-	-	10.81	3546-3/8X1.5DP	-	-	-	-
1/2	14	1.5D 0.75"	5	-	-	17.29	3546-1/2X1.5DP	-	-	-	-
5/8	14	1.5D 0.94"	5	-	-	12.61	3546-5/8X1.5DP	-	-	-	-
5/8	14	2.0D 1.25"	5	-	-	-	-	17.04	3546-5/8X2.0DP	-	
3/4	14	1.0D 0.75"	5	11.62	3546-3/4X1.0DP	-	-	-	-	-	-
3/4	14	1.5D 1.13"	5	-	-	12.61	3546-3/4X1.5DP	-	-	-	-
7/8	14	1.5D 1.32"	3	-	-	10.78	3546-7/8X1.5DP	-	-	-	-
1	11	1.5D 1.50"	3	-	-	10.26	3546-1X1.5DP	-	-	-	-

NPT											
INCH	TPI	INSTALLED LENGTH	#	€	PART #	€	PART #	€	PART #	€	PART #
1/16	27	1.5D 0.09"	10	-	-	7.37	3552-1/16X1.5DP	-	-	-	-
1/8	27	1.5D 0.19"	10	-	-	7.37	3552-1/8X1.5DP	-	-	-	-
1/4	18	1.5D 0.38"	10	-	-	10.78	3552-1/4X1.5DP	-	-	-	-
3/8	18	1.5D 0.56"	10	-	-	13.48	3552-3/8X1.5DP	-	-	-	-
1/2	14	1.5D 0.75"	5	-	-	11.01	3552-1/2X1.5DP	-	-	-	-
3/4	14	1.5D 1.13"	5	-	-	16.18	3552-3/4X1.5DP	-	-	-	-
1	11	1.5D 1.50"	3	-	-	12.80	3552-1X1.5DP	-	-	-	-



GROUP	PCRK
INSERT TYPE	WIRE THREAD
INSERT MATERIAL	304 STAINLESS STEEL
STYLE	FREE RUNNING

MERCHANDISER	€	PART #
POWERCOIL HANG SELL MERCHANDISER	1650.75	3500-D1

CONTENTS			
			
#	MM / INCH	PART #	PART #
METRIC COARSE			
1	4 x 0.7	3520-4.00K	3520-4.00 x 1.5DP
1	5 x 0.8	3520-5.00K	3520-5.00 x 1.5DP
1	6 x 1.0	3520-6.00K	3520-6.00 x 1.5DP
1	6 x 1.0	–	3520-6.00 x 2.0DP
1	8 x 1.25	3520-8.00K	3520-8.00 x 1.5DP
1	8 x 1.25	–	3520-8.00 x 2.0DP
1	10 x 1.5	3520-10.00K	3520-10.00 x 1.5DP
1	12 x 1.75	3520-12.00K	3520-12.00 x 1.5DP
1	12 x 1.75	–	3520-12.00 x 2.0DP
1	16 x 2.0	3520-16.00K	3520-16.00 x 1.5DP
1	10 x 1.25	3521-10.00K	3521-10.00 x 1.5DP
1	12 x 1.5	3521-12.00K	3521-12.00 x 1.5DP
SPARK PLUG			
1	12 x 1.25	3522-12.00K	3522-12.00 x 1/2P
1	12 x 1.25	–	3522-12.00 x 3/4P
1	14 x 1.25	3522-14.00K	3522-14.00 x 3/8P
1	14 x 1.25	–	3522-14.00 x 1/2P
1	14 x 1.25	–	3522-14.00 x 3/4P
UNC			
1	1/4 x 20	3532-1/4K	3532-1/4 x 1.5DP
1	5/16 x 18	3532-5/16K	3532-5/16 x 1.5DP
1	3/8 x 16	3532-3/8K	3532-3/8 x 1.5DP
1	3/8 x 16	–	3532-3/8 x 2.0DP
1	7/16 x 14	3532-7/16K	3532-7/16 x 1.5DP
1	1/2 x 13	3532-1/2K	3532-1/2 x 1.5DP
1	5/8 x 11	3532-5/8K	3532-5/8 x 1.5DP
1	3/4 x 10	3532-3/4K	3532-3/4 x 1.5DP
UNF			
1	1/4 x 28	3534-1/4K	3534-1/4 x 1.5DP
1	5/16 x 24	3534-5/16K	3534-5/16 x 1.5DP
1	3/8 x 24	3534-3/8K	3534-3/8 x 1.5DP
1	7/16 x 20	3534-7/16K	3534-7/16 x 1.5DP
1	1/2 x 20	3534-1/2K	3534-1/2 x 1.5DP
BSW			
1	1/2 x 12	3528-1/2K	3528-1/2 x 1.5DP



Picture is representative of merchandiser appearance.
Actual contents as listed.



MC



GROUP	PCRK
INSERT TYPE	WIRE THREAD
INSERT MATERIAL	304 STAINLESS STEEL
STYLE	FREE RUNNING

MERCHANDISER	€	PART #
POWERCOIL BENCH MERCHANDISER	467.97	3500-CS1

CONTENTS

#	MM / INCH	PART #	PART #
METRIC COARSE			
1	5 x 0.8	3520-5.00K	3520-5.00 x 1.5DP
1	6 x 1.0	3520-6.00K	3520-6.00 x 1.0DP
1	6 x 1.0	-	3520-6.00 x 1.5DP
1	6 x 1.0	-	3520-6.00 x 2.0DP
1	8 x 1.25	3520-8.00K	3520-8.00 x 1.0DP
1	8 x 1.25	-	3520-8.00 x 1.5DP
1	8 x 1.25	-	3520-8.00 x 2.0DP
1	10 x 1.5	3520-10.00K	3520-10.00 x 1.5DP
1	10 x 1.5	-	3520-10.00 x 2.0DP
1	12 x 1.75	3520-12.00K	3520-12.00 x 1.5DP
1	16 x 2.0	3520-16.00K	3520-16.00 x 1.5DP
SPARK PLUG			
1	14 x 1.25	3522-14.00K	3522-14.00 x 3/8P
1	14 x 1.25	-	3522-14.00 x 1/2P
1	14 x 1.25	-	3522-14.00 x 3/4P





PowerCoil bench merchandisers are double sided units that display thread repair kits on one side and replacement insert packets on the other.



PowerCoil bench merchandisers are double sided units that display thread repair kits on one side and replacement insert packets on the other.

GROUP	PCRK
INSERT TYPE	WIRE THREAD
INSERT MATERIAL	304 STAINLESS STEEL
STYLE	FREE RUNNING

MERCHANDISER	€	PART #
POWERCOIL HANG SELL MERCHANDISER	465.02	3500-CS2

CONTENTS			
#	MM / INCH	PART #	PART #
			
	METRIC COARSE		
1	6 x 1.0	3520-6.00K	3520-6.00 x 1.0DP
1	6 x 1.0	—	3520-6.00 x 1.5DP
1	6 x 1.0	—	3520-6.00 x 2.0DP
1	8 x 1.25	3520-8.00K	3520-8.00 x 1.0DP
1	8 x 1.25	—	3520-8.00 x 1.5DP
1	8 x 1.25	—	3520-8.00 x 2.0DP
1	10 x 1.5	3520-10.00K	3520-10.00 x 1.5DP
1	12 x 1.75	3520-12.00K	3520-12.00 x 1.5DP
	UNC		
1	1/4 x 20	3532-1/4K	3532-1/4 x 1.5DP
1	5/16 x 18	3532-5/16K	3532-5/16 x 1.5DP
1	3/8 x 16	3532-3/8K	3532-3/8 x 1.5DP
1	3/8 x 16	—	3532-3/8 x 2.0DP
1	1/2 x 13	3532-1/2K	3532-1/2 x 1.5DP



**MC
UNC**



MC

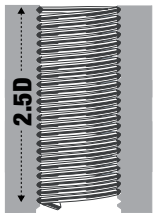
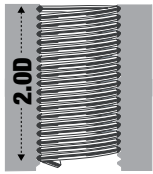

GROUP	PCWI
INSERT TYPE	WIRE THREAD
INSERT MATERIAL	304 STAINLESS STEEL
STYLE	FREE RUNNING

METRIC COARSE – 2.0D BULK INSERTS

D	MM	MM	MM	PART #	€ EACH													
					1	3	5	10	50	100	250	500	1000	5000	10000	100K+		
2.00	0.40	4.00	3520-2.00X2.0D	–	–	0.270	0.270	0.270	0.270	0.270	0.270	0.270	0.270	0.220	0.220	0.194	0.171	POA
2.20	0.45	4.40	3520-2.20X2.0D	–	–	0.257	0.257	0.257	0.257	0.257	0.257	0.257	0.257	0.210	0.210	0.185	0.163	POA
2.50	0.45	5.00	3520-2.50X2.0D	–	–	0.234	0.234	0.234	0.234	0.234	0.234	0.234	0.234	0.191	0.191	0.169	0.148	POA
3.00	0.50	6.00	3520-3.00X2.0D	–	–	0.234	0.234	0.234	0.234	0.234	0.234	0.234	0.234	0.191	0.191	0.169	0.148	POA
3.50	0.60	7.00	3520-3.50X2.0D	–	–	0.257	0.257	0.257	0.257	0.257	0.257	0.257	0.257	0.210	0.210	0.185	0.163	POA
4.00	0.70	8.00	3520-4.00X2.0D	–	–	0.234	0.234	0.234	0.234	0.234	0.234	0.234	0.234	0.191	0.191	0.169	0.148	POA
5.00	0.80	10.00	3520-5.00X2.0D	–	–	0.234	0.234	0.234	0.234	0.234	0.234	0.234	0.234	0.191	0.191	0.169	0.148	POA
6.00	1.00	12.00	3520-6.00X2.0D	–	–	0.234	0.234	0.234	0.234	0.234	0.234	0.234	0.234	0.191	0.191	0.169	0.148	POA
7.00	1.00	14.00	3520-7.00X2.0D	–	–	0.257	0.257	0.257	0.257	0.257	0.257	0.257	0.257	0.210	0.210	0.185	0.163	POA
8.00	1.25	16.00	3520-8.00X2.0D	–	–	0.333	0.333	0.333	0.333	0.333	0.333	0.333	0.333	0.271	0.271	0.240	0.210	POA
9.00	1.25	18.00	3520-9.00X2.0D	–	–	0.433	0.433	0.433	0.433	0.433	0.433	0.433	0.433	0.353	0.353	0.312	0.273	POA
10.00	1.50	20.00	3520-10.00X2.0D	–	–	0.424	0.424	0.424	0.424	0.424	0.424	0.424	0.424	0.345	0.345	0.305	0.268	POA
11.00	1.50	22.00	3520-11.00X2.0D	–	–	0.679	0.679	0.679	0.679	0.679	0.679	0.679	0.679	0.553	0.553	0.489	0.429	POA
12.00	1.75	24.00	3520-12.00X2.0D	–	–	0.679	0.679	0.679	0.679	0.679	0.679	0.679	0.679	0.553	0.553	0.489	0.429	POA
13.00	1.75	26.00	3520-13.00X2.0D	–	–	0.815	0.815	0.815	0.815	0.815	0.815	0.815	0.815	0.663	0.663	0.587	0.557	POA
14.00	2.00	28.00	3520-14.00X2.0D	–	–	0.923	0.923	0.923	0.923	0.923	0.923	0.923	0.923	0.818	0.818	0.736	0.699	POA
15.00	2.00	30.00	3520-15.00X2.0D	–	–	1.061	1.061	1.061	1.061	1.061	1.061	1.061	1.061	0.941	0.941	0.846	0.804	POA
16.00	2.00	32.00	3520-16.00X2.0D	–	–	1.174	1.174	1.174	1.174	1.174	1.174	1.174	1.174	1.041	1.041	0.936	0.889	POA
18.00	2.50	36.00	3520-18.00X2.0D	–	–	1.644	1.644	1.644	1.644	1.644	1.644	1.644	1.644	1.457	1.457	1.311	1.311	POA
20.00	2.50	40.00	3520-20.00X2.0D	–	–	1.677	1.677	1.677	1.677	1.677	1.677	1.677	1.677	1.534	1.534	1.534	1.534	POA
22.00	2.50	44.00	3520-22.00X2.0D	–	–	2.258	2.258	2.258	2.258	2.258	2.258	2.258	2.258	2.066	2.066	2.066	2.066	POA
24.00	3.00	48.00	3520-24.00X2.0D	–	–	2.914	2.914	2.914	2.914	2.914	2.914	2.914	2.914	2.666	2.666	2.666	2.666	POA

METRIC COARSE – 2.5D BULK INSERTS

D	MM	MM	MM	PART #	€ EACH													
					1	3	5	10	50	100	250	500	1000	5000	10000	100K+		
2.00	0.40	5.00	3520-2.00X2.5D	–	–	0.285	0.285	0.285	0.285	0.285	0.285	0.285	0.285	0.232	0.232	0.205	0.180	POA
2.20	0.45	5.50	3520-2.20X2.5D	–	–	0.272	0.272	0.272	0.272	0.272	0.272	0.272	0.272	0.221	0.221	0.196	0.172	POA
2.50	0.45	6.25	3520-2.50X2.5D	–	–	0.248	0.248	0.248	0.248	0.248	0.248	0.248	0.248	0.202	0.202	0.178	0.156	POA
3.00	0.50	7.50	3520-3.00X2.5D	–	–	0.248	0.248	0.248	0.248	0.248	0.248	0.248	0.248	0.202	0.202	0.178	0.156	POA
3.50	0.60	8.75	3520-3.50X2.5D	–	–	0.272	0.272	0.272	0.272	0.272	0.272	0.272	0.272	0.221	0.221	0.196	0.172	POA
4.00	0.70	10.00	3520-4.00X2.5D	–	–	0.261	0.261	0.261	0.261	0.261	0.261	0.261	0.261	0.213	0.213	0.188	0.165	POA
5.00	0.80	12.50	3520-5.00X2.5D	–	–	0.261	0.261	0.261	0.261	0.261	0.261	0.261	0.261	0.213	0.213	0.188	0.165	POA
6.00	1.00	15.00	3520-6.00X2.5D	–	–	0.261	0.261	0.261	0.261	0.261	0.261	0.261	0.261	0.213	0.213	0.188	0.165	POA
7.00	1.00	17.50	3520-7.00X2.5D	–	–	0.287	0.287	0.287	0.287	0.287	0.287	0.287	0.287	0.234	0.234	0.207	0.181	POA
8.00	1.25	20.00	3520-8.00X2.5D	–	–	0.411	0.411	0.411	0.411	0.411	0.411	0.411	0.411	0.335	0.335	0.296	0.260	POA
9.00	1.25	22.50	3520-9.00X2.5D	–	–	0.535	0.535	0.535	0.535	0.535	0.535	0.535	0.535	0.435	0.435	0.385	0.338	POA
10.00	1.50	25.00	3520-10.00X2.5D	–	–	0.528	0.528	0.528	0.528	0.528	0.528	0.528	0.528	0.430	0.430	0.381	0.334	POA
11.00	1.50	27.50	3520-11.00X2.5D	–	–	0.913	0.913	0.913	0.913	0.913	0.913	0.913	0.913	0.743	0.743	0.657	0.576	POA
12.00	1.75	30.00	3520-12.00X2.5D	–	–	0.913	0.913	0.913	0.913	0.913	0.913	0.913	0.913	0.743	0.743	0.657	0.576	POA
14.00	2.00	35.00	3520-14.00X2.5D	–	–	1.135	1.135	1.135	1.135	1.135	1.135	1.135	1.135	1.007	1.007	0.905	0.859	POA
16.00	2.00	40.00	3520-16.00X2.5D	–	–	1.409	1.409	1.409	1.409	1.409	1.409	1.409	1.409	1.249	1.249	1.124	1.067	POA
18.00	2.50	45.00	3520-18.00X2.5D	–	–	1.940	1.940	1.940	1.940	1.940	1.940	1.940	1.940	1.720	1.720	1.547	1.547	POA
20.00	2.50	50.00	3520-20.00X2.5D	–	–	2.167	2.167	2.167	2.167	2.167	2.167	2.167	2.167	1.983	1.983	1.983	1.983	POA
22.00	2.50	55.00	3520-22.00X2.5D	–	–	2.933	2.933	2.933	2.933	2.933	2.933	2.933	2.933	2.684	2.684	2.684	2.684	POA
24.00	3.00	60.00	3520-24.00X2.5D	–	–	4.280	4.280	4.280	4.280	4.280	4.280	4.280	4.280	3.150	3.150	3.150	3.150	POA



GROUP	PCWI
INSERT TYPE	WIRE THREAD
INSERT MATERIAL	304 STAINLESS STEEL
STYLE	FREE RUNNING

METRIC COARSE – 3.0D BULK INSERTS

D	MM	MM	MM	PART #	€ EACH													
					1	3	5	10	50	100	250	500	1000	5000	10000	100K+		
2.00	0.40	6.00	3520-2.00X3.0D	-	-	0.316	0.316	0.316	0.316	0.316	0.316	0.316	0.316	0.257	0.257	0.228	0.200	POA
2.20	0.45	6.60	3520-2.20X3.0D	-	-	0.302	0.302	0.302	0.302	0.302	0.302	0.302	0.302	0.246	0.246	0.217	0.190	POA
2.50	0.45	7.50	3520-2.50X3.0D	-	-	0.275	0.275	0.275	0.275	0.275	0.275	0.275	0.275	0.224	0.224	0.198	0.173	POA
3.00	0.50	9.00	3520-3.00X3.0D	-	-	0.275	0.275	0.275	0.275	0.275	0.275	0.275	0.275	0.224	0.224	0.198	0.173	POA
3.50	0.60	10.50	3520-3.50X3.0D	-	-	0.302	0.302	0.302	0.302	0.302	0.302	0.302	0.302	0.246	0.246	0.217	0.190	POA
4.00	0.70	12.00	3520-4.00X3.0D	-	-	0.294	0.294	0.294	0.294	0.294	0.294	0.294	0.294	0.240	0.240	0.212	0.186	POA
5.00	0.80	15.00	3520-5.00X3.0D	-	-	0.294	0.294	0.294	0.294	0.294	0.294	0.294	0.294	0.240	0.240	0.212	0.186	POA
6.00	1.00	18.00	3520-6.00X3.0D	-	-	0.294	0.294	0.294	0.294	0.294	0.294	0.294	0.294	0.240	0.240	0.212	0.186	POA
7.00	1.00	21.00	3520-7.00X3.0D	-	-	0.324	0.324	0.324	0.324	0.324	0.324	0.324	0.324	0.264	0.264	0.233	0.205	POA
8.00	1.25	24.00	3520-8.00X3.0D	-	-	0.483	0.483	0.483	0.483	0.483	0.483	0.483	0.483	0.394	0.394	0.348	0.305	POA
9.00	1.25	27.00	3520-9.00X3.0D	-	-	0.628	0.628	0.628	0.628	0.628	0.628	0.628	0.628	0.512	0.512	0.452	0.397	POA
10.00	1.50	30.00	3520-10.00X3.0D	-	-	0.632	0.632	0.632	0.632	0.632	0.632	0.632	0.632	0.515	0.515	0.455	0.399	POA
11.00	1.50	33.00	3520-11.00X3.0D	-	-	1.129	1.129	1.129	1.129	1.129	1.129	1.129	1.129	0.919	0.919	0.813	0.713	POA
12.00	1.75	36.00	3520-12.00X3.0D	-	-	1.129	1.129	1.129	1.129	1.129	1.129	1.129	1.129	0.919	0.919	0.813	0.713	POA
14.00	2.00	42.00	3520-14.00X3.0D	-	-	1.314	1.314	1.314	1.314	1.314	1.314	1.314	1.314	1.165	1.165	1.048	0.995	POA
16.00	2.00	48.00	3520-16.00X3.0D	-	-	1.666	1.666	1.666	1.666	1.666	1.666	1.666	1.666	1.477	1.477	1.328	1.262	POA
18.00	2.50	54.00	3520-18.00X3.0D	-	-	2.231	2.231	2.231	2.231	2.231	2.231	2.231	2.231	1.978	1.978	1.779	1.779	POA
20.00	2.50	60.00	3520-20.00X3.0D	-	-	2.490	2.490	2.490	2.490	2.490	2.490	2.490	2.490	2.278	2.278	2.278	2.278	POA
22.00	2.50	66.00	3520-22.00X3.0D	-	-	3.413	3.413	3.413	3.413	3.413	3.413	3.413	3.413	3.123	3.123	3.123	3.123	POA
24.00	3.00	72.00	3520-24.00X3.0D	-	-	5.021	5.021	5.021	5.021	5.021	5.021	5.021	5.021	3.308	3.308	3.308	3.308	POA

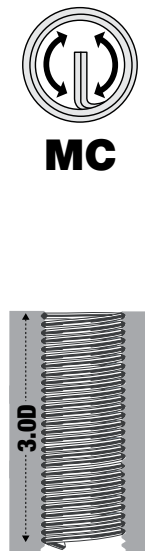

Screw Locking Wire Thread Inserts

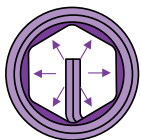

Screw locking (or prevailing torque) inserts are of particular value in applications subject to the effects of cyclic vibration or impact. In addition to the benefits afforded by free running inserts, PowerCoil screw locking inserts offer the additional security of prevailing locking torque. This is achieved by the action of one or more polygonal grip coils positioned within the insert's length, which exert radial pressure on the male thread. Each grip coil consists of a number of tangential locking chords which protrude inside the minor diameter of the normal free running coils. As the male thread passes through these grip coils, the locking flats are displaced thus exerting radial pressure or prevailing torque on the male thread. On removal of the male thread, the locking coils relax to their original form permitting repeated assembly whilst retaining a measurable level of prevailing torque.

Note: It is recommended that only close fit plated or lubricated bolts or screws are used with screw locking inserts.

Call for the latest pricing and availability.





















MF



GROUP	PCWI
INSERT TYPE	WIRE THREAD
INSERT MATERIAL	304 STAINLESS STEEL
STYLE	FREE RUNNING

METRIC FINE – 1.0D BULK INSERTS

																			€	€	€	€	€	€	€	€	€	€	€
																			EACH	EACH	EACH	EACH	EACH	EACH	EACH	EACH	EACH	EACH	EACH
MM	MM	MM	PART #	1	3	5	10	50	100	250	500	1000	5000	10000	100K+														
6.00	0.75	6.00	3521-6.00X1.0D	-	-	0.251	0.251	0.251	0.251	0.251	0.251	0.251	0.204	0.204	0.180	0.158	POA												
8.00	1.00	8.00	3521-8.00X1.0D	-	-	0.234	0.234	0.234	0.234	0.234	0.234	0.234	0.191	0.191	0.169	0.148	POA												
8.00	0.75	8.00	3523-8.00X1.0D	-	-	0.281	0.281	0.281	0.281	0.281	0.281	0.281	0.229	0.229	0.202	0.177	POA												
9.00	1.00	9.00	3521-9.00X1.0D	-	-	0.304	0.304	0.304	0.304	0.304	0.304	0.304	0.248	0.248	0.219	0.192	POA												
10.00	1.25	10.00	3521-10.00X1.0D	-	-	0.267	0.267	0.267	0.267	0.267	0.267	0.267	0.218	0.218	0.193	0.169	POA												
10.00	1.00	10.00	3523-10.00X1.0D	-	-	0.267	0.267	0.267	0.267	0.267	0.267	0.267	0.218	0.218	0.193	0.169	POA												
11.00	1.25	11.00	3521-11.00X1.0D	-	-	0.326	0.326	0.326	0.326	0.326	0.326	0.326	0.265	0.265	0.235	0.206	POA												
11.00	1.00	11.00	3523-11.00X1.0D	-	-	0.326	0.326	0.326	0.326	0.326	0.326	0.326	0.265	0.265	0.235	0.206	POA												
12.00	1.50	12.00	3521-12.00X1.0D	-	-	0.326	0.326	0.326	0.326	0.326	0.326	0.326	0.265	0.265	0.235	0.206	POA												
12.00	1.25	12.00	3523-12.00X1.0D	-	-	0.326	0.326	0.326	0.326	0.326	0.326	0.326	0.265	0.265	0.235	0.206	POA												
12.00	1.00	12.00	3524-12.00X1.0D	-	-	0.447	0.447	0.447	0.447	0.447	0.447	0.447	0.270	0.270	0.447	0.331	POA												
13.00	1.50	13.00	3521-13.00X1.0D	-	-	0.391	0.391	0.391	0.391	0.391	0.391	0.391	0.318	0.318	0.282	0.268	POA												
13.00	1.25	13.00	3523-13.00X1.0D	-	-	0.391	0.391	0.391	0.391	0.391	0.391	0.391	0.318	0.318	0.282	0.268	POA												
14.00	1.50	14.00	3521-14.00X1.0D	-	-	0.570	0.570	0.570	0.570	0.570	0.570	0.570	0.506	0.506	0.455	0.432	POA												
14.00	1.25	14.00	3523-14.00X1.0D	-	-	0.604	0.604	0.604	0.604	0.604	0.604	0.604	0.544	0.544	0.505	0.479	POA												
14.00	1.00	14.00	3524-14.00X1.0D	-	-	0.690	0.690	0.690	0.690	0.690	0.690	0.690	0.621	0.621	0.577	0.548	POA												
15.00	1.50	15.00	3521-15.00X1.0D	-	-	0.656	0.656	0.656	0.656	0.656	0.656	0.656	0.582	0.582	0.523	0.496	POA												
16.00	1.50	16.00	3521-16.00X1.0D	-	-	0.766	0.766	0.766	0.766	0.766	0.766	0.766	0.679	0.679	0.610	0.579	POA												
18.00	2.00	18.00	3521-18.00X1.0D	-	-	1.040	1.040	1.040	1.040	1.040	1.040	1.040	0.922	0.922	0.829	0.829	POA												
18.00	1.50	18.00	3523-18.00X1.0D	-	-	1.040	1.040	1.040	1.040	1.040	1.040	1.040	0.922	0.922	0.829	0.829	POA												
20.00	2.00	20.00	3521-20.00X1.0D	-	-	1.060	1.060	1.060	1.060	1.060	1.060	1.060	0.970	0.970	0.970	0.970	POA												
20.00	1.50	20.00	3523-20.00X1.0D	-	-	1.060	1.060	1.060	1.060	1.060	1.060	1.060	0.970	0.970	0.970	0.970	POA												
22.00	2.00	22.00	3521-22.00X1.0D	-	-	1.463	1.463	1.463	1.463	1.463	1.463	1.463	1.339	1.339	1.339	1.339	POA												
22.00	1.50	22.00	3523-22.00X1.0D	-	-	1.463	1.463	1.463	1.463	1.463	1.463	1.463	1.339	1.339	1.339	1.339	POA												
24.00	2.00	24.00	3521-24.00X1.0D	-	-	1.836	1.836	1.836	1.836	1.836	1.836	1.836	1.680	1.680	1.680	1.680	POA												
24.00	1.50	24.00	3523-24.00X1.0D	-	-	1.836	1.836	1.836	1.836	1.836	1.836	1.836	1.680	1.680	1.680	1.680	POA												



Strip Feed
Free Running Inserts
Page 46



GROUP	PCWI
INSERT TYPE	WIRE THREAD
INSERT MATERIAL	304 STAINLESS STEEL
STYLE	FREE RUNNING

METRIC FINE – 1.5D BULK INSERTS

 MF	 1.5D	 1.5D	PART #	<table border="1"> <tr> <td>€</td><td>€</td><td>€</td><td>€</td><td>€</td><td>€</td><td>€</td><td>€</td><td>€</td><td>€</td><td>€</td><td>€</td><td>€</td><td>€</td><td>€</td><td>€</td><td>€</td><td>€</td><td>€</td><td>€</td> </tr> <tr> <td>EACH</td><td>EACH</td><td>EACH</td><td>EACH</td><td>EACH</td><td>EACH</td><td>EACH</td><td>EACH</td><td>EACH</td><td>EACH</td><td>EACH</td><td>EACH</td><td>EACH</td><td>EACH</td><td>EACH</td><td>EACH</td><td>EACH</td><td>EACH</td><td>EACH</td><td>EACH</td><td>EACH</td> </tr> </table>															€	€	€	€	€	€	€	€	€	€	€	€	€	€	€	€	€	€	€	€	EACH	EACH	EACH	EACH	EACH	EACH	EACH	EACH	EACH	EACH	EACH	EACH	EACH	EACH	EACH	EACH	EACH	EACH	EACH	EACH	EACH
				€	€	€	€	€	€	€	€	€	€	€	€	€	€	€	€	€	€	€	€																																				
EACH	EACH	EACH	EACH	EACH	EACH	EACH	EACH	EACH	EACH	EACH	EACH	EACH	EACH	EACH	EACH	EACH	EACH	EACH	EACH	EACH																																							
MM	MM	MM		1	3	5	10	50	100	250	500	1000	5000	10000	100K+																																												
6.00	0.75	9.00	3521-6.00X1.5D	-	-	0.267	0.267	0.267	0.267	0.267	0.267	0.267	0.217	0.217	0.192	0.169	POA																																										
8.00	1.00	12.00	3521-8.00X1.5D	-	-	0.275	0.275	0.275	0.275	0.275	0.275	0.275	0.224	0.224	0.198	0.173	POA																																										
8.00	0.75	12.00	3523-8.00X1.5D	-	-	0.330	0.330	0.330	0.330	0.330	0.330	0.330	0.268	0.268	0.237	0.208	POA																																										
9.00	1.00	13.50	3521-9.00X1.5D	-	-	0.357	0.357	0.357	0.357	0.357	0.357	0.357	0.291	0.291	0.257	0.226	POA																																										
10.00	1.25	15.00	3521-10.00X1.5D	-	-	0.320	0.320	0.320	0.320	0.320	0.320	0.320	0.260	0.260	0.230	0.202	POA																																										
10.00	1.00	15.00	3523-10.00X1.5D	-	-	0.320	0.320	0.320	0.320	0.320	0.320	0.320	0.260	0.260	0.230	0.202	POA																																										
11.00	1.25	16.50	3521-11.00X1.5D	-	-	0.502	0.502	0.502	0.502	0.502	0.502	0.502	0.409	0.409	0.362	0.317	POA																																										
11.00	1.00	16.50	3523-11.00X1.5D	-	-	0.502	0.502	0.502	0.502	0.502	0.502	0.502	0.409	0.409	0.362	0.317	POA																																										
12.00	1.50	18.00	3521-12.00X1.5D	-	-	0.502	0.502	0.502	0.502	0.502	0.502	0.502	0.409	0.409	0.362	0.317	POA																																										
12.00	1.25	18.00	3523-12.00X1.5D	-	-	0.502	0.502	0.502	0.502	0.502	0.502	0.502	0.409	0.409	0.362	0.317	POA																																										
12.00	1.00	18.00	3524-12.00X1.5D	-	-	0.689	0.689	0.689	0.689	0.689	0.689	0.689	0.408	0.408	0.689	0.501	POA																																										
13.00	1.50	19.50	3521-13.00X1.5D	-	-	0.603	0.603	0.603	0.603	0.603	0.603	0.603	0.491	0.491	0.434	0.412	POA																																										
13.00	1.25	19.50	3523-13.00X1.5D	-	-	0.603	0.603	0.603	0.603	0.603	0.603	0.603	0.491	0.491	0.434	0.412	POA																																										
14.00	1.50	21.00	3521-14.00X1.5D	-	-	0.727	0.727	0.727	0.727	0.727	0.727	0.727	0.645	0.645	0.580	0.551	POA																																										
14.00	1.25	21.00	3523-14.00X1.5D	-	-	0.663	0.663	0.663	0.663	0.663	0.663	0.663	0.596	0.596	0.554	0.526	POA																																										
14.00	1.00	21.00	3524-14.00X1.5D	-	-	0.868	0.868	0.868	0.868	0.868	0.868	0.868	0.781	0.781	0.725	0.688	POA																																										
15.00	1.50	22.50	3521-15.00X1.5D	-	-	0.836	0.836	0.836	0.836	0.836	0.836	0.836	0.741	0.741	0.667	0.633	POA																																										
16.00	1.50	24.00	3521-16.00X1.5D	-	-	0.939	0.939	0.939	0.939	0.939	0.939	0.939	0.833	0.833	0.749	0.711	POA																																										
18.00	2.00	27.00	3521-18.00X1.5D	-	-	1.354	1.354	1.354	1.354	1.354	1.354	1.354	1.200	1.200	1.079	1.079	POA																																										
18.00	1.50	27.00	3523-18.00X1.5D	-	-	1.354	1.354	1.354	1.354	1.354	1.354	1.354	1.200	1.200	1.079	1.079	POA																																										
20.00	2.00	30.00	3521-20.00X1.5D	-	-	1.381	1.381	1.381	1.381	1.381	1.381	1.381	1.263	1.263	1.263	1.263	POA																																										
20.00	1.50	30.00	3523-20.00X1.5D	-	-	1.381	1.381	1.381	1.381	1.381	1.381	1.381	1.263	1.263	1.263	1.263	POA																																										
22.00	2.00	33.00	3521-22.00X1.5D	-	-	1.836	1.836	1.836	1.836	1.836	1.836	1.836	1.680	1.680	1.680	1.680	POA																																										
22.00	1.50	33.00	3523-22.00X1.5D	-	-	1.836	1.836	1.836	1.836	1.836	1.836	1.836	1.680	1.680	1.680	1.680	POA																																										
24.00	2.00	36.00	3521-24.00X1.5D	-	-	2.395	2.395	2.395	2.395	2.395	2.395	2.395	2.192	2.192	2.192	2.192	POA																																										
24.00	1.50	36.00	3523-24.00X1.5D	-	-	2.395	2.395	2.395	2.395	2.395	2.395	2.395	2.192	2.192	2.192	2.192	POA																																										
26.00	1.50	39.00	3523-26.00X1.5D	-	-	2.331	2.331	2.331	2.331	2.331	2.331	2.331	2.331	2.331	2.331	2.331	POA																																										
27.00	2.00	40.50	3521-27.00X1.5D	-	-	2.549	2.549	2.549	2.549	2.549	2.549	2.549	2.549	2.549	2.549	2.549	POA																																										
27.00	1.50	40.50	3523-27.00X1.5D	-	-	2.318	2.318	2.318	2.318	2.318	2.318	2.318	2.318	2.318	2.318	2.318	POA																																										
28.00	1.50	42.00	3523-28.00X1.5D	-	-	2.498	2.498	2.498	2.498	2.498	2.498	2.498	2.498	2.498	2.498	2.498	POA																																										
30.00	2.00	45.00	3521-30.00X1.5D	-	-	3.038	2.978	2.918	2.860	2.803	2.747	2.692	2.692	2.692	2.692	2.692	POA																																										
30.00	1.50	45.00	3523-30.00X1.5D	-	-	2.831	2.775	2.720	2.666	2.613	2.561	2.510	2.510	2.510	2.510	2.510	POA																																										
33.00	2.00	49.50	3521-33.00X1.5D	-	-	4.419	4.331	4.244	4.159	4.076	3.994	3.914	3.914	3.914	3.914	3.914	POA																																										
36.00	3.00	54.00	3521-36.00X1.5D	-	-	5.942	5.823	5.707	5.593	5.481	5.371	5.264	5.264	5.264	5.264	5.264	POA																																										
36.00	2.00	54.00	3523-36.00X1.5D	-	-	4.697	4.603	4.511	4.421	4.333	4.246	4.161	4.161	4.161	4.161	4.161	POA																																										
36.00	1.50	54.00	3524-36.00X1.5D	-	-	4.697	4.603	4.511	4.421	4.333	4.246	4.161	4.161	4.161	4.161	4.161	POA																																										



GROUP	PCWI
INSERT TYPE	WIRE THREAD
INSERT MATERIAL	304 STAINLESS STEEL
STYLE	FREE RUNNING

METRIC FINE – 3.0D BULK INSERTS

 MF	 3.0D			PART #	<table border="1"> <tr> <td>€</td><td>€</td><td>€</td><td>€</td><td>€</td><td>€</td><td>€</td><td>€</td><td>€</td><td>€</td><td>€</td><td>€</td><td>€</td><td>€</td><td>€</td><td>€</td><td>€</td><td>€</td> </tr> <tr> <td>EACH</td><td>EACH</td><td>EACH</td><td>EACH</td><td>EACH</td><td>EACH</td><td>EACH</td><td>EACH</td><td>EACH</td><td>EACH</td><td>EACH</td><td>EACH</td><td>EACH</td><td>EACH</td><td>EACH</td><td>EACH</td><td>EACH</td><td>EACH</td> </tr> </table>													€	€	€	€	€	€	€	€	€	€	€	€	€	€	€	€	€	€	EACH	EACH	EACH	EACH	EACH	EACH	EACH	EACH	EACH	EACH	EACH	EACH	EACH	EACH	EACH	EACH	EACH	EACH
					€	€	€	€	€	€	€	€	€	€	€	€	€	€	€	€	€	€																															
EACH	EACH	EACH	EACH	EACH	EACH	EACH	EACH	EACH	EACH	EACH	EACH	EACH	EACH	EACH	EACH	EACH	EACH																																				
MM	MM	MM	MM	1	3	5	10	50	100	250	500	1000	5000	10000	100K+																																						
6.00	0.75	18.00	3521-6.00X3.0D	-	-	0.353	0.353	0.353	0.353	0.353	0.353	0.353	0.288	0.288	0.254	0.223	POA																																				
8.00	1.00	24.00	3521-8.00X3.0D	-	-	0.483	0.483	0.483	0.483	0.483	0.483	0.483	0.394	0.394	0.348	0.305	POA																																				
8.00	0.75	24.00	3523-8.00X3.0D	-	-	0.580	0.580	0.580	0.580	0.580	0.580	0.580	0.472	0.472	0.418	0.366	POA																																				
9.00	1.00	27.00	3521-9.00X3.0D	-	-	0.628	0.628	0.628	0.628	0.628	0.628	0.628	0.512	0.512	0.452	0.397	POA																																				
10.00	1.25	30.00	3521-10.00X3.0D	-	-	0.632	0.632	0.632	0.632	0.632	0.632	0.632	0.515	0.515	0.455	0.399	POA																																				
10.00	1.00	30.00	3523-10.00X3.0D	-	-	0.632	0.632	0.632	0.632	0.632	0.632	0.632	0.515	0.515	0.455	0.399	POA																																				
11.00	1.25	33.00	3521-11.00X3.0D	-	-	1.129	1.129	1.129	1.129	1.129	1.129	1.129	0.919	0.919	0.813	0.713	POA																																				
11.00	1.00	33.00	3523-11.00X3.0D	-	-	1.129	1.129	1.129	1.129	1.129	1.129	1.129	0.919	0.919	0.813	0.713	POA																																				
12.00	1.50	36.00	3521-12.00X3.0D	-	-	1.129	1.129	1.129	1.129	1.129	1.129	1.129	0.919	0.919	0.813	0.713	POA																																				
12.00	1.25	36.00	3523-12.00X3.0D	-	-	1.129	1.129	1.129	1.129	1.129	1.129	1.129	0.919	0.919	0.813	0.713	POA																																				
12.00	1.00	36.00	3524-12.00X3.0D	-	-	1.703	1.703	1.703	1.703	1.703	1.703	1.703	0.919	0.919	0.813	0.713	POA																																				
14.00	1.50	42.00	3521-14.00X3.0D	-	-	1.314	1.314	1.314	1.314	1.314	1.314	1.314	1.165	1.165	1.048	0.995	POA																																				
14.00	1.25	42.00	3523-14.00X3.0D	-	-	0.970	0.970	0.970	0.970	0.970	0.970	0.970	0.873	0.873	0.810	0.769	POA																																				
14.00	1.00	42.00	3524-14.00X3.0D	-	-	1.301	1.301	1.301	1.301	1.301	1.301	1.301	1.170	1.170	1.087	1.033	POA																																				
16.00	1.50	48.00	3521-16.00X3.0D	-	-	1.666	1.666	1.666	1.666	1.666	1.666	1.666	1.477	1.477	1.328	1.262	POA																																				
18.00	2.00	54.00	3521-18.00X3.0D	-	-	2.231	2.231	2.231	2.231	2.231	2.231	2.231	1.978	1.978	1.779	1.779	POA																																				
18.00	1.50	54.00	3523-18.00X3.0D	-	-	2.231	2.231	2.231	2.231	2.231	2.231	2.231	1.978	1.978	1.779	1.779	POA																																				
20.00	2.00	60.00	3521-20.00X3.0D	-	-	2.490	2.490	2.490	2.490	2.490	2.490	2.490	2.278	2.278	2.278	2.278	POA																																				
20.00	1.50	60.00	3523-20.00X3.0D	-	-	2.490	2.490	2.490	2.490	2.490	2.490	2.490	2.278	2.278	2.278	2.278	POA																																				
22.00	2.00	66.00	3521-22.00X3.0D	-	-	3.413	3.413	3.413	3.413	3.413	3.413	3.413	3.123	3.123	3.123	3.123	POA																																				
22.00	1.50	66.00	3523-22.00X3.0D	-	-	3.413	3.413	3.413	3.413	3.413	3.413	3.413	3.123	3.123	3.123	3.123	POA																																				
24.00	2.00	72.00	3521-24.00X3.0D	-	-	5.021	5.021	5.021	5.021	5.021	5.021	5.021	3.308	3.308	3.308	3.308	POA																																				
24.00	1.50	72.00	3523-24.00X3.0D	-	-	5.021	5.021	5.021	5.021	5.021	5.021	5.021	3.308	3.308	3.308	3.308	POA																																				

SPARK PLUG – BULK INSERTS

 MF	 3.0D			<table border="1"> <tr> <td>€</td><td>€</td><td>€</td><td>€</td><td>€</td><td>€</td><td>€</td><td>€</td><td>€</td><td>€</td><td>€</td><td>€</td><td>€</td><td>€</td><td>€</td><td>€</td><td>€</td><td>€</td> </tr> <tr> <td>EACH</td><td>EACH</td><td>EACH</td><td>EACH</td><td>EACH</td><td>EACH</td><td>EACH</td><td>EACH</td><td>EACH</td><td>EACH</td><td>EACH</td><td>EACH</td><td>EACH</td><td>EACH</td><td>EACH</td><td>EACH</td><td>EACH</td><td>EACH</td> </tr> </table>													€	€	€	€	€	€	€	€	€	€	€	€	€	€	€	€	€	€	EACH	EACH	EACH	EACH	EACH	EACH	EACH	EACH	EACH	EACH	EACH	EACH	EACH	EACH	EACH	EACH	EACH	EACH
				€	€	€	€	€	€	€	€	€	€	€	€	€	€	€	€	€	€																															
EACH	EACH	EACH	EACH	EACH	EACH	EACH	EACH	EACH	EACH	EACH	EACH	EACH	EACH	EACH	EACH	EACH	EACH																																			
MM	MM	MM	MM	1	3	5	10	50	100	250	500	1000	5000	10000	100K+																																					
IMPERIAL LENGTH																																																				
10.00	1.00	0.339"	3522-10.00X.339	-	-	0.267	0.267	0.267	0.267	0.267	0.267	0.267	0.217	0.217	0.206	0.183	POA																																			
10.00	1.00	1/2"	3522-10.00X1/2	-	-	0.326	0.326	0.326	0.326	0.326	0.326	0.326	0.265	0.265	0.251	0.224	POA																																			
12.00	1.25	1/2"	3522-12.00X1/2	-	-	0.326	0.326	0.326	0.326	0.326	0.326	0.326	0.265	0.265	0.235	0.206	POA																																			
12.00	1.25	3/4"	3522-12.00X3/4	-	-	0.502	0.502	0.502	0.502	0.502	0.502	0.502	0.409	0.409	0.362	0.317	POA																																			
14.00	1.25	7/16"	3522-14.00X7/16	-	-	0.545	0.545	0.545	0.545	0.545	0.545	0.545	0.454	0.454	0.431	0.431	POA																																			
14.00	1.25	3/8"	3522-14.00X3/8	-	-	0.361	0.361	0.361	0.361	0.361	0.361	0.361	0.299	0.299	0.284	0.284	POA																																			
14.00	1.25	1/2"	3522-14.00X1/2	-	-	0.545	0.545	0.545	0.545	0.545	0.545	0.545	0.454	0.454	0.431	0.431	POA																																			
14.00	1.25	3/4"	3522-14.00X3/4	-	-	0.828	0.828	0.828	0.828	0.828	0.828	0.828	0.689	0.689	0.654	0.654	POA																																			
18.00	1.50	1/2"	3522-18.00X1/2	-	-	0.731	0.731	0.731	0.731	0.731	0.731	0.731	0.608	0.608	0.578	0.578	POA																																			
METRIC LENGTH																																																				
14.00	1.25	8.4MM	3522-14.00X8.4	-	-	0.361	0.361	0.361	0.361	0.361	0.361	0.361	0.299	0.299	0.284	0.284	POA																																			
14.00	1.25	12.4MM	3522-14.00X12.4	-	-	0.545	0.545	0.545	0.545	0.545	0.545	0.545	0.454	0.454	0.431	0.431	POA																																			
14.00	1.25	16.4MM	3522-14.00X16.4	-	-	0.828	0.828	0.828	0.828	0.828	0.828	0.828	0.689	0.689	0.654	0.654	POA																																			



UNC

2.0D, 2.5D



GROUP	PCWI
INSERT TYPE	WIRE THREAD
INSERT MATERIAL	304 STAINLESS STEEL
STYLE	FREE RUNNING

UNC – 2.0D BULK INSERTS

						€	€	€	€	€	€	€	€	€	€	€	€
						EACH	EACH	EACH	EACH	EACH	EACH	EACH	EACH	EACH	EACH	EACH	EACH
INCH	TPI	INCH	PART #	1	3	5	10	50	100	250	500	1000	5000	10000	100K+		
2G	56	0.18	3532-2GX2.0D	-	-	0.313	0.313	0.313	0.313	0.313	0.313	0.313	0.255	0.255	0.215	0.215	POA
3G	48	0.20	3532-3GX2.0D	-	-	0.313	0.313	0.313	0.313	0.313	0.313	0.313	0.255	0.255	0.215	0.215	POA
4G	40	0.22	3532-4GX2.0D	-	-	0.246	0.246	0.246	0.246	0.246	0.246	0.246	0.201	0.201	0.169	0.169	POA
5G	40	0.26	3532-5GX2.0D	-	-	0.270	0.270	0.270	0.270	0.270	0.270	0.270	0.221	0.221	0.185	0.185	POA
6G	32	0.28	3532-6GX2.0D	-	-	0.246	0.246	0.246	0.246	0.246	0.246	0.246	0.201	0.201	0.169	0.169	POA
8G	32	0.32	3532-8GX2.0D	-	-	0.246	0.246	0.246	0.246	0.246	0.246	0.246	0.201	0.201	0.169	0.169	POA
10G	24	0.38	3532-10GX2.0D	-	-	0.246	0.246	0.246	0.246	0.246	0.246	0.246	0.201	0.201	0.169	0.169	POA
12G	24	0.44	3532-12GX2.0D	-	-	0.270	0.270	0.270	0.270	0.270	0.270	0.270	0.221	0.221	0.185	0.185	POA
1/4	20	0.50	3532-1/4X2.0D	-	-	0.246	0.246	0.246	0.246	0.246	0.246	0.246	0.201	0.201	0.169	0.169	POA
5/16	18	0.62	3532-5/16X2.0D	-	-	0.350	0.350	0.350	0.350	0.350	0.350	0.350	0.286	0.286	0.240	0.240	POA
3/8	16	0.76	3532-3/8X2.0D	-	-	0.445	0.445	0.445	0.445	0.445	0.445	0.445	0.363	0.363	0.305	0.305	POA
7/16	14	0.88	3532-7/16X2.0D	-	-	0.527	0.527	0.527	0.527	0.527	0.527	0.527	0.431	0.431	0.361	0.361	POA
1/2	13	1.00	3532-1/2X2.0D	-	-	0.712	0.712	0.712	0.712	0.712	0.712	0.712	0.582	0.582	0.489	0.489	POA
9/16	12	1.12	3532-9/16X2.0D	-	-	0.923	0.923	0.923	0.923	0.923	0.923	0.923	0.818	0.818	0.818	0.818	POA
5/8	11	1.26	3532-5/8X2.0D	-	-	1.174	1.174	1.174	1.174	1.174	1.174	1.174	1.041	1.041	1.041	1.041	POA
3/4	10	1.50	3532-3/4X2.0D	-	-	1.644	1.644	1.644	1.644	1.644	1.644	1.644	1.457	1.457	1.457	1.457	POA
7/8	9	1.76	3532-7/8X2.0D	-	-	2.214	2.214	2.214	2.214	2.214	2.214	2.214	2.046	2.046	2.046	2.046	POA
1	8	2.00	3532-1X2.0D	-	-	2.857	2.857	2.857	2.857	2.857	2.857	2.857	2.640	2.640	2.640	2.640	POA

UNC – 2.5D BULK INSERTS

						€	€	€	€	€	€	€	€	€	€	€	€
						EACH	EACH	EACH	EACH	EACH	EACH	EACH	EACH	EACH	EACH	EACH	EACH
INCH	TPI	INCH	PART #	1	3	5	10	50	100	250	500	1000	5000	10000	100K+		
2G	56	0.23	3532-2GX2.5D	-	-	0.332	0.332	0.332	0.332	0.332	0.332	0.332	0.271	0.271	0.228	0.228	POA
4G	48	0.25	3532-4GX2.5D	-	-	0.260	0.260	0.260	0.260	0.260	0.260	0.260	0.212	0.212	0.178	0.178	POA
5G	40	0.28	3532-5GX2.5D	-	-	0.285	0.285	0.285	0.285	0.285	0.285	0.285	0.233	0.233	0.196	0.196	POA
6G	40	0.33	3532-6GX2.5D	-	-	0.260	0.260	0.260	0.260	0.260	0.260	0.260	0.212	0.212	0.178	0.178	POA
8G	32	0.35	3532-8GX2.5D	-	-	0.274	0.274	0.274	0.274	0.274	0.274	0.274	0.224	0.224	0.188	0.188	POA
10G	32	0.40	3532-10GX2.5D	-	-	0.274	0.274	0.274	0.274	0.274	0.274	0.274	0.224	0.224	0.188	0.188	POA
12G	24	0.48	3532-12GX2.5D	-	-	0.285	0.285	0.285	0.285	0.285	0.285	0.285	0.233	0.233	0.196	0.196	POA
1/4	24	0.55	3532-1/4X2.5D	-	-	0.274	0.274	0.274	0.274	0.274	0.274	0.274	0.224	0.224	0.188	0.188	POA
5/16	20	0.63	3532-5/16X2.5D	-	-	0.432	0.432	0.432	0.432	0.432	0.432	0.432	0.353	0.353	0.296	0.296	POA
3/8	18	0.78	3532-3/8X2.5D	-	-	0.555	0.555	0.555	0.555	0.555	0.555	0.555	0.453	0.453	0.381	0.381	POA
7/16	16	0.95	3532-7/16X2.5D	-	-	0.663	0.663	0.663	0.663	0.663	0.663	0.663	0.542	0.542	0.455	0.455	POA
1/2	14	1.10	3532-1/2X2.5D	-	-	0.958	0.958	0.958	0.958	0.958	0.958	0.958	0.782	0.782	0.657	0.657	POA
9/16	13	1.25	3532-9/16X2.5D	-	-	1.135	1.135	1.135	1.135	1.135	1.135	1.135	1.007	1.007	1.007	1.007	POA
5/8	12	1.40	3532-5/8X2.5D	-	-	1.409	1.409	1.409	1.409	1.409	1.409	1.409	1.249	1.249	1.249	1.249	POA
3/4	11	1.58	3532-3/4X2.5D	-	-	1.940	1.940	1.940	1.940	1.940	1.940	1.940	1.720	1.720	1.720	1.720	POA
7/8	10	1.88	3532-7/8X2.5D	-	-	2.622	2.622	2.622	2.622	2.622	2.622	2.622	2.423	2.423	2.423	2.423	POA
1	8	2.50	3532-1X2.5D	-	-	3.727	3.727	3.727	3.727	3.727	3.727	3.727	3.444	3.444	3.444	3.444	POA



UNC

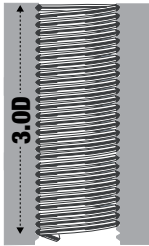

GROUP	PCWI
INSERT TYPE	WIRE THREAD
INSERT MATERIAL	304 STAINLESS STEEL
STYLE	FREE RUNNING

UNC – 3.0D BULK INSERTS

				3.0D	€													
					EACH	EACH	EACH	EACH	EACH	EACH	EACH	EACH	EACH	EACH	EACH	EACH	EACH	
INCH	TPI	INCH	PART #		1	3	5	10	50	100	250	500	1000	5000	10000	100K+		
2G	56	0.27	3532-2GX3.0D	–	0.368	0.368	0.368	0.368	0.368	0.368	0.368	0.300	0.300	0.252	0.252	POA		
4G	40	0.33	3532-4GX3.0D	–	0.288	0.288	0.288	0.288	0.288	0.288	0.288	0.235	0.235	0.198	0.198	POA		
5G	40	0.39	3532-5GX3.0D	–	0.317	0.317	0.317	0.317	0.317	0.317	0.317	0.259	0.259	0.217	0.217	POA		
6G	32	0.42	3532-6GX3.0D	–	0.288	0.288	0.288	0.288	0.288	0.288	0.288	0.235	0.235	0.198	0.198	POA		
8G	32	0.48	3532-8GX3.0D	–	0.309	0.309	0.309	0.309	0.309	0.309	0.309	0.252	0.252	0.212	0.212	POA		
10G	24	0.57	3532-10GX3.0D	–	0.309	0.309	0.309	0.309	0.309	0.309	0.309	0.252	0.252	0.212	0.212	POA		
12G	24	0.66	3532-12GX3.0D	–	0.317	0.317	0.317	0.317	0.317	0.317	0.317	0.259	0.259	0.217	0.217	POA		
1/4	20	0.75	3532-1/4X3.0D	–	0.309	0.309	0.309	0.309	0.309	0.309	0.309	0.252	0.252	0.212	0.212	POA		
5/16	18	0.93	3532-5/16X3.0D	–	0.508	0.508	0.508	0.508	0.508	0.508	0.508	0.414	0.414	0.348	0.348	POA		
3/8	16	1.14	3532-3/8X3.0D	–	0.664	0.664	0.664	0.664	0.664	0.664	0.664	0.542	0.542	0.455	0.455	POA		
7/16	14	1.32	3532-7/16X3.0D	–	0.794	0.794	0.794	0.794	0.794	0.794	0.794	0.648	0.648	0.544	0.544	POA		
1/2	13	1.50	3532-1/2X3.0D	–	1.180	1.180	1.180	1.180	1.180	1.180	1.180	0.967	0.967	0.813	0.813	POA		
9/16	12	1.68	3532-9/16X3.0D	–	1.314	1.314	1.314	1.314	1.314	1.314	1.314	1.165	1.165	1.165	1.165	POA		
5/8	11	1.89	3532-5/8X3.0D	–	1.666	1.666	1.666	1.666	1.666	1.666	1.666	1.477	1.477	1.477	1.477	POA		
3/4	10	2.25	3532-3/4X3.0D	–	2.231	2.231	2.231	2.231	2.231	2.231	2.231	1.978	1.978	1.978	1.978	POA		
7/8	9	2.64	3532-7/8X3.0D	–	3.052	3.052	3.052	3.052	3.052	3.052	3.052	2.820	2.820	2.820	2.820	POA		
1	8	3.00	3532-1X3.0D	–	4.287	4.287	4.287	4.287	4.287	4.287	4.287	3.961	3.961	3.961	3.961	POA		



BSW

1.0D, 1.5D, 2.0D



GROUP	PCWI
INSERT TYPE	WIRE THREAD
INSERT MATERIAL	304 STAINLESS STEEL
STYLE	FREE RUNNING

BSW – 1.0D BULK INSERTS

				1.0D													
				€ EACH	€ EACH	€ EACH	€ EACH	€ EACH	€ EACH	€ EACH	€ EACH	€ EACH	€ EACH	€ EACH	€ EACH	€ EACH	€ EACH
INCH	TPI	INCH	PART #	1	3	5	10	50	100	250	500	1000	5000	10000	100K+		
1/8	40	0.13	3528-1/8X1.0D	-	-	0.241	0.241	0.241	0.241	0.241	0.241	0.241	0.187	0.187	0.187	POA	
3/16	24	0.19	3528-3/16X1.0D	-	-	0.219	0.219	0.219	0.219	0.219	0.219	0.219	0.170	0.170	0.170	POA	
1/4	20	0.25	3528-1/4X1.0D	-	-	0.219	0.219	0.219	0.219	0.219	0.219	0.219	0.170	0.170	0.170	POA	
5/16	18	0.31	3528-5/16X1.0D	-	-	0.246	0.246	0.246	0.246	0.246	0.246	0.246	0.191	0.191	0.191	POA	
3/8	16	0.38	3528-3/8X1.0D	-	-	0.281	0.281	0.281	0.281	0.281	0.281	0.281	0.218	0.218	0.218	POA	
7/16	14	0.44	3528-7/16X1.0D	-	-	0.321	0.321	0.321	0.321	0.321	0.321	0.321	0.250	0.250	0.250	POA	
1/2	12	0.50	3528-1/2X1.0D	-	-	0.342	0.342	0.342	0.342	0.342	0.342	0.342	0.266	0.266	0.266	POA	
9/16	12	0.56	3528-9/16X1.0D	-	-	0.699	0.699	0.699	0.699	0.699	0.699	0.699	0.504	0.504	0.504	POA	
5/8	11	0.63	3528-5/8X1.0D	-	-	0.938	0.938	0.938	0.938	0.938	0.938	0.938	0.677	0.677	0.677	POA	
3/4	10	0.75	3528-3/4X1.0D	-	-	1.273	1.273	1.273	1.273	1.273	1.273	1.273	0.919	0.919	0.919	POA	
7/8	9	0.88	3528-7/8X1.0D	-	-	1.402	1.402	1.402	1.402	1.402	1.402	1.402	1.265	1.265	1.265	POA	
1	8	1.00	3528-1X1.0D	-	-	1.764	1.764	1.764	1.764	1.764	1.764	1.764	1.592	1.592	1.592	POA	

BSW – 1.5D BULK INSERTS

				1.5D													
				€ EACH	€ EACH	€ EACH	€ EACH	€ EACH	€ EACH	€ EACH	€ EACH	€ EACH	€ EACH	€ EACH	€ EACH	€ EACH	€ EACH
INCH	TPI	INCH	PART #	1	3	5	10	50	100	250	500	1000	5000	10000	100K+		
1/8	40	0.20	3528-1/8X1.5D	-	-	0.257	0.257	0.257	0.257	0.257	0.257	0.257	0.200	0.200	0.200	POA	
3/16	24	0.29	3528-3/16X1.5D	-	-	0.234	0.234	0.234	0.234	0.234	0.234	0.234	0.181	0.181	0.181	POA	
1/4	20	0.38	3528-1/4X1.5D	-	-	0.234	0.234	0.234	0.234	0.234	0.234	0.234	0.181	0.181	0.181	POA	
5/16	18	0.47	3528-5/16X1.5D	-	-	0.288	0.288	0.288	0.288	0.288	0.288	0.288	0.224	0.224	0.224	POA	
3/8	16	0.57	3528-3/8X1.5D	-	-	0.336	0.336	0.336	0.336	0.336	0.336	0.336	0.261	0.261	0.261	POA	
7/16	14	0.66	3528-7/16X1.5D	-	-	0.390	0.390	0.390	0.390	0.390	0.390	0.390	0.303	0.303	0.303	POA	
1/2	12	0.75	3528-1/2X1.5D	-	-	0.528	0.528	0.528	0.528	0.528	0.528	0.528	0.410	0.410	0.410	POA	
9/16	12	0.84	3528-9/16X1.5D	-	-	0.891	0.891	0.891	0.891	0.891	0.891	0.891	0.643	0.643	0.643	POA	
5/8	11	0.95	3528-5/8X1.5D	-	-	1.151	1.151	1.151	1.151	1.151	1.151	1.151	0.830	0.830	0.830	POA	
3/4	10	1.13	3528-3/4X1.5D	-	-	1.658	1.658	1.658	1.658	1.658	1.658	1.658	1.197	1.197	1.197	POA	
7/8	9	1.32	3528-7/8X1.5D	-	-	1.764	1.764	1.764	1.764	1.764	1.764	1.764	1.592	1.592	1.592	POA	
1	8	1.50	3528-1X1.5D	-	-	2.301	2.301	2.301	2.301	2.301	2.301	2.301	2.076	2.076	2.076	POA	

BSW – 2.0D BULK INSERTS

				2.0D													
				€ EACH	€ EACH	€ EACH	€ EACH	€ EACH	€ EACH	€ EACH	€ EACH	€ EACH	€ EACH	€ EACH	€ EACH	€ EACH	€ EACH
INCH	TPI	INCH	PART #	1	3	5	10	50	100	250	500	1000	5000	10000	100K+		
1/8	40	0.26	3528-1/8X2.0D	-	-	0.270	0.270	0.270	0.270	0.270	0.270	0.270	0.210	0.210	0.210	POA	
3/16	24	0.38	3528-3/16X2.0D	-	-	0.246	0.246	0.246	0.246	0.246	0.246	0.246	0.191	0.191	0.191	POA	
1/4	20	0.50	3528-1/4X2.0D	-	-	0.246	0.246	0.246	0.246	0.246	0.246	0.246	0.191	0.191	0.191	POA	
5/16	18	0.62	3528-5/16X2.0D	-	-	0.350	0.350	0.350	0.350	0.350	0.350	0.350	0.272	0.272	0.272	POA	
3/8	16	0.76	3528-3/8X2.0D	-	-	0.445	0.445	0.445	0.445	0.445	0.445	0.445	0.346	0.346	0.346	POA	
7/16	14	0.88	3528-7/16X2.0D	-	-	0.528	0.528	0.528	0.528	0.528	0.528	0.528	0.410	0.410	0.410	POA	
1/2	12	1.00	3528-1/2X2.0D	-	-	0.713	0.713	0.713	0.713	0.713	0.713	0.713	0.554	0.554	0.554	POA	
9/16	12	1.12	3528-9/16X2.0D	-	-	1.131	1.131	1.131	1.131	1.131	1.131	1.131	0.816	0.816	0.816	POA	
5/8	11	1.26	3528-5/8X2.0D	-	-	1.438	1.438	1.438	1.438	1.438	1.438	1.438	1.038	1.038	1.038	POA	
3/4	10	1.50	3528-3/4X2.0D	-	-	2.014	2.014	2.014	2.014	2.014	2.014	2.014	1.453	1.453	1.453	POA	
7/8	9	1.76	3528-7/8X2.0D	-	-	2.170	2.170	2.170	2.170	2.170	2.170	2.170	1.957	1.957	1.957	POA	
1	8	2.00	3528-1X2.0D	-	-	2.800	2.800	2.800	2.800	2.800	2.800	2.800	2.526	2.526	2.526	POA	



BSW

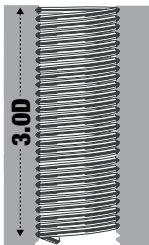
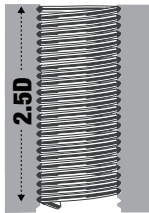

GROUP	PCWI
INSERT TYPE	WIRE THREAD
INSERT MATERIAL	304 STAINLESS STEEL
STYLE	FREE RUNNING

BSW – 2.5D BULK INSERTS

INCH	TPI	INCH	PART #	€ EACH															
				1	3	5	10	50	100	250	500	1000	5000	10000	100K+				
1/8	40	0.33	3528-1/8X2.5D	–	–	0.285	0.285	0.285	0.285	0.285	0.285	0.285	0.285	0.222	0.222	0.222	0.222	POA	
3/16	24	0.48	3528-3/16X2.5D	–	–	0.285	0.285	0.285	0.285	0.285	0.285	0.285	0.285	0.221	0.221	0.221	0.221	POA	
1/4	20	0.63	3528-1/4X2.5D	–	–	0.300	0.300	0.300	0.300	0.300	0.300	0.300	0.300	0.233	0.233	0.233	0.233	POA	
5/16	18	0.78	3528-5/16X2.5D	–	–	0.473	0.473	0.473	0.473	0.473	0.473	0.473	0.473	0.367	0.367	0.367	0.367	POA	
3/8	16	0.95	3528-3/8X2.5D	–	–	0.608	0.608	0.608	0.608	0.608	0.608	0.608	0.608	0.472	0.472	0.472	0.472	POA	
7/16	14	1.10	3528-7/16X2.5D	–	–	0.727	0.727	0.727	0.727	0.727	0.727	0.727	0.727	0.565	0.565	0.565	0.565	POA	
1/2	12	1.25	3528-1/2X2.5D	–	–	1.050	1.050	1.050	1.050	1.050	1.050	1.050	1.050	0.816	0.816	0.816	0.816	POA	
9/16	12	1.40	3528-9/16X2.5D	–	–	1.523	1.523	1.523	1.523	1.523	1.523	1.523	1.523	1.099	1.099	1.099	1.099	POA	
5/8	11	1.58	3528-5/8X2.5D	–	–	1.891	1.891	1.891	1.891	1.891	1.891	1.891	1.891	1.364	1.364	1.364	1.364	POA	
3/4	10	1.88	3528-3/4X2.5D	–	–	2.603	2.603	2.603	2.603	2.603	2.603	2.603	2.603	1.878	1.878	1.878	1.878	POA	
7/8	9	2.20	3528-7/8X2.5D	–	–	2.814	2.814	2.814	2.814	2.814	2.814	2.814	2.814	2.538	2.538	2.538	2.538	POA	
1	8	2.50	3528-1X2.5D	–	–	3.654	3.654	3.654	3.654	3.654	3.654	3.654	3.654	3.296	3.296	3.296	3.296	POA	

BSW – 3.0D BULK INSERTS

INCH	TPI	INCH	PART #	€ EACH															
				1	3	5	10	50	100	250	500	1000	5000	10000	100K+				
1/8	40	0.39	3528-1/8X3.0D	–	–	0.317	0.317	0.317	0.317	0.317	0.317	0.317	0.317	0.246	0.246	0.246	0.246	POA	
3/16	24	0.57	3528-3/16X3.0D	–	–	0.316	0.316	0.316	0.316	0.316	0.316	0.316	0.316	0.245	0.245	0.245	0.245	POA	
1/4	20	0.75	3528-1/4X3.0D	–	–	0.338	0.338	0.338	0.338	0.338	0.338	0.338	0.338	0.263	0.263	0.263	0.263	POA	
5/16	18	0.93	3528-5/16X3.0D	–	–	0.556	0.556	0.556	0.556	0.556	0.556	0.556	0.556	0.432	0.432	0.432	0.432	POA	
3/8	16	1.14	3528-3/8X3.0D	–	–	0.727	0.727	0.727	0.727	0.727	0.727	0.727	0.727	0.565	0.565	0.565	0.565	POA	
7/16	14	1.32	3528-7/16X3.0D	–	–	0.870	0.870	0.870	0.870	0.870	0.870	0.870	0.870	0.676	0.676	0.676	0.676	POA	
1/2	12	1.50	3528-1/2X3.0D	–	–	1.298	1.298	1.298	1.298	1.298	1.298	1.298	1.298	1.009	1.009	1.009	1.009	POA	
9/16	12	1.68	3528-9/16X3.0D	–	–	1.763	1.763	1.763	1.763	1.763	1.763	1.763	1.763	1.272	1.272	1.272	1.272	POA	
5/8	11	1.89	3528-5/8X3.0D	–	–	2.235	2.235	2.235	2.235	2.235	2.235	2.235	2.235	1.613	1.613	1.613	1.613	POA	
3/4	10	2.25	3528-3/4X3.0D	–	–	2.993	2.993	2.993	2.993	2.993	2.993	2.993	2.993	2.160	2.160	2.160	2.160	POA	
7/8	9	2.64	3528-7/8X3.0D	–	–	3.276	3.276	3.276	3.276	3.276	3.276	3.276	3.276	2.955	2.955	2.955	2.955	POA	
1	8	3.00	3528-1X3.0D	–	–	4.201	4.201	4.201	4.201	4.201	4.201	4.201	4.201	3.790	3.790	3.790	3.790	POA	







BSF

1.0D, 1.5D, 2.0D







GROUP	PCWI
INSERT TYPE	WIRE THREAD
INSERT MATERIAL	304 STAINLESS STEEL
STYLE	FREE RUNNING





BSF – 1.0D BULK INSERTS

																		€ EACH	€ EACH	€ EACH	€ EACH	€ EACH	€ EACH	€ EACH	€ EACH	€ EACH	€ EACH	€ EACH
				INCH	TPI	INCH	PART #	1	3	5	10	50	100	250	500	1000	5000											
3/16	32	0.19	3530-3/16X1.0D	-	-	0.219	0.219	0.219	0.219	0.219	0.219	0.219	0.170	0.170	0.170	0.170	POA											
1/4	26	0.25	3530-1/4X1.0D	-	-	0.219	0.219	0.219	0.219	0.219	0.219	0.219	0.170	0.170	0.170	0.170	POA											
5/16	22	0.31	3530-5/16X1.0D	-	-	0.246	0.246	0.246	0.246	0.246	0.246	0.246	0.191	0.191	0.191	0.191	POA											
3/8	20	0.38	3530-3/8X1.0D	-	-	0.281	0.281	0.281	0.281	0.281	0.281	0.281	0.218	0.218	0.218	0.218	POA											
7/16	18	0.44	3530-7/16X1.0D	-	-	0.321	0.321	0.321	0.321	0.321	0.321	0.321	0.250	0.250	0.250	0.250	POA											
1/2	16	0.50	3530-1/2X1.0D	-	-	0.342	0.342	0.342	0.342	0.342	0.342	0.342	0.266	0.266	0.266	0.266	POA											
9/16	16	0.56	3530-9/16X1.0D	-	-	0.599	0.599	0.599	0.599	0.599	0.599	0.599	0.504	0.504	0.504	0.504	POA											
5/8	14	0.63	3530-5/8X1.0D	-	-	0.804	0.804	0.804	0.804	0.804	0.804	0.804	0.677	0.677	0.677	0.677	POA											
3/4	12	0.75	3530-3/4X1.0D	-	-	1.091	1.091	1.091	1.091	1.091	1.091	1.091	0.919	0.919	0.919	0.919	POA											
7/8	11	0.88	3530-7/8X1.0D	-	-	1.402	1.402	1.402	1.402	1.402	1.402	1.402	1.265	1.265	1.265	1.265	POA											
1	10	1.00	3530-1X1.0D	-	-	1.764	1.764	1.764	1.764	1.764	1.764	1.764	1.592	1.592	1.592	1.592	POA											

BSF – 1.5D BULK INSERTS

																		€ EACH	€ EACH	€ EACH	€ EACH	€ EACH	€ EACH	€ EACH	€ EACH	€ EACH	€ EACH
				INCH	TPI	INCH	PART #	1	3	5	10	50	100	250	500	1000	5000										
3/16	32	0.29	3530-3/16X1.5D	-	-	0.234	0.234	0.234	0.234	0.234	0.234	0.234	0.181	0.181	0.181	0.181	POA										
1/4	26	0.38	3530-1/4X1.5D	-	-	0.234	0.234	0.234	0.234	0.234	0.234	0.234	0.181	0.181	0.181	0.181	POA										
5/16	22	0.47	3530-5/16X1.5D	-	-	0.288	0.288	0.288	0.288	0.288	0.288	0.288	0.224	0.224	0.224	0.224	POA										
3/8	20	0.57	3530-3/8X1.5D	-	-	0.336	0.336	0.336	0.336	0.336	0.336	0.336	0.261	0.261	0.261	0.261	POA										
7/16	18	0.66	3530-7/16X1.5D	-	-	0.390	0.390	0.390	0.390	0.390	0.390	0.390	0.303	0.303	0.303	0.303	POA										
1/2	16	0.75	3530-1/2X1.5D	-	-	0.528	0.528	0.528	0.528	0.528	0.528	0.528	0.410	0.410	0.410	0.410	POA										
9/16	16	0.84	3530-9/16X1.5D	-	-	0.763	0.763	0.763	0.763	0.763	0.763	0.763	0.643	0.643	0.643	0.643	POA										
5/8	14	0.95	3530-5/8X1.5D	-	-	0.986	0.986	0.986	0.986	0.986	0.986	0.986	0.830	0.830	0.830	0.830	POA										
3/4	12	1.13	3530-3/4X1.5D	-	-	1.421	1.421	1.421	1.421	1.421	1.421	1.421	1.197	1.197	1.197	1.197	POA										
7/8	11	1.32	3530-7/8X1.5D	-	-	1.764	1.764	1.764	1.764	1.764	1.764	1.764	1.592	1.592	1.592	1.592	POA										
1	10	1.50	3530-1X1.5D	-	-	2.301	2.301	2.301	2.301	2.301	2.301	2.301	2.076	2.076	2.076	2.076	POA										

BSF – 2.0D BULK INSERTS

																		€ EACH	€ EACH	€ EACH	€ EACH	€ EACH	€ EACH	€ EACH	€ EACH	€ EACH	€ EACH
				INCH	TPI	INCH	PART #	1	3	5	10	50	100	250	500	1000	5000										
3/16	32	0.38	3530-3/16X2.0D	-	-	0.246	0.246	0.246	0.246	0.246	0.246	0.246	0.191	0.191	0.191	0.191	POA										
1/4	26	0.50	3530-1/4X2.0D	-	-	0.246	0.246	0.246	0.246	0.246	0.246	0.246	0.191	0.191	0.191	0.191	POA										
5/16	22	0.62	3530-5/16X2.0D	-	-	0.350	0.350	0.350	0.350	0.350	0.350	0.350	0.272	0.272	0.272	0.272	POA										
3/8	20	0.76	3530-3/8X2.0D	-	-	0.445	0.445	0.445	0.445	0.445	0.445	0.445	0.346	0.346	0.346	0.346	POA										
7/16	18	0.88	3530-7/16X2.0D	-	-	0.528	0.528	0.528	0.528	0.528	0.528	0.528	0.410	0.410	0.410	0.410	POA										
1/2	16	1.00	3530-1/2X2.0D	-	-	0.713	0.713	0.713	0.713	0.713	0.713	0.713	0.554	0.554	0.554	0.554	POA										
9/16	16	1.12	3530-9/16X2.0D	-	-	0.969	0.969	0.969	0.969	0.969	0.969	0.969	0.816	0.816	0.816	0.816	POA										
5/8	14	1.26	3530-5/8X2.0D	-	-	1.232	1.232	1.232	1.232	1.232	1.232	1.232	1.038	1.038	1.038	1.038	POA										
3/4	12	1.50	3530-3/4X2.0D	-	-	1.726	1.726	1.726	1.726	1.726	1.726	1.726	1.453	1.453	1.453	1.453	POA										
7/8	11	1.76	3530-7/8X2.0D	-	-	2.170	2.170	2.170	2.170	2.170	2.170	2.170	1.957	1.957	1.957	1.957	POA										
1	10	2.00	3530-1X2.0D	-	-	2.800	2.800	2.800	2.800	2.800	2.800	2.800	2.526	2.526	2.526	2.526	POA										



BSF

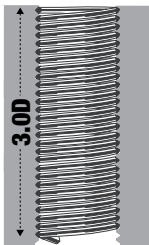
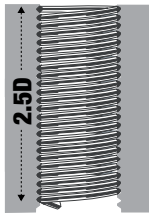

GROUP	PCWI
INSERT TYPE	WIRE THREAD
INSERT MATERIAL	304 STAINLESS STEEL
STYLE	FREE RUNNING

BSF – 2.5D BULK INSERTS

				2.5D														
					€ EACH	€ EACH	€ EACH	€ EACH	€ EACH	€ EACH	€ EACH	€ EACH	€ EACH	€ EACH	€ EACH	€ EACH	€ EACH	
INCH	TPI	INCH	PART #		1	3	5	10	50	100	250	500	1000	5000	10000	100K+		
3/16	32	0.48	3530-3/16X2.5D	–	–	0.285	0.285	0.285	0.285	0.285	0.285	0.285	0.221	0.221	0.221	0.221	POA	
1/4	26	0.63	3530-1/4X2.5D	–	–	0.300	0.300	0.300	0.300	0.300	0.300	0.300	0.233	0.233	0.233	0.233	POA	
5/16	22	0.78	3530-5/16X2.5D	–	–	0.473	0.473	0.473	0.473	0.473	0.473	0.473	0.367	0.367	0.367	0.367	POA	
3/8	20	0.95	3530-3/8X2.5D	–	–	0.608	0.608	0.608	0.608	0.608	0.608	0.608	0.472	0.472	0.472	0.472	POA	
7/16	18	1.10	3530-7/16X2.5D	–	–	0.727	0.727	0.727	0.727	0.727	0.727	0.727	0.565	0.565	0.565	0.565	POA	
1/2	16	1.25	3530-1/2X2.5D	–	–	1.050	1.050	1.050	1.050	1.050	1.050	1.050	0.816	0.816	0.816	0.816	POA	
9/16	16	1.40	3530-9/16X2.5D	–	–	1.305	1.305	1.305	1.305	1.305	1.305	1.305	1.099	1.099	1.099	1.099	POA	
5/8	14	1.58	3530-5/8X2.5D	–	–	1.621	1.621	1.621	1.621	1.621	1.621	1.621	1.364	1.364	1.364	1.364	POA	
3/4	12	1.88	3530-3/4X2.5D	–	–	2.231	2.231	2.231	2.231	2.231	2.231	2.231	1.878	1.878	1.878	1.878	POA	
7/8	11	2.20	3530-7/8X2.5D	–	–	2.814	2.814	2.814	2.814	2.814	2.814	2.814	2.538	2.538	2.538	2.538	POA	
1	10	2.50	3530-1X2.5D	–	–	3.654	3.654	3.654	3.654	3.654	3.654	3.654	3.296	3.296	3.296	3.296	POA	

BSF – 3.0D BULK INSERTS

				3.0D														
					€ EACH	€ EACH	€ EACH	€ EACH	€ EACH	€ EACH	€ EACH	€ EACH	€ EACH	€ EACH	€ EACH	€ EACH	€ EACH	
INCH	TPI	INCH	PART #		1	3	5	10	50	100	250	500	1000	5000	10000	100K+		
3/16	32	0.57	3530-3/16X3.0D	–	–	0.316	0.316	0.316	0.316	0.316	0.316	0.316	0.245	0.245	0.245	0.245	POA	
1/4	26	0.75	3530-1/4X3.0D	–	–	0.338	0.338	0.338	0.338	0.338	0.338	0.338	0.263	0.263	0.263	0.263	POA	
5/16	22	0.93	3530-5/16X3.0D	–	–	0.556	0.556	0.556	0.556	0.556	0.556	0.556	0.432	0.432	0.432	0.432	POA	
3/8	20	1.14	3530-3/8X3.0D	–	–	0.727	0.727	0.727	0.727	0.727	0.727	0.727	0.565	0.565	0.565	0.565	POA	
7/16	18	1.32	3530-7/16X3.0D	–	–	0.870	0.870	0.870	0.870	0.870	0.870	0.870	0.676	0.676	0.676	0.676	POA	
1/2	16	1.50	3530-1/2X3.0D	–	–	1.298	1.298	1.298	1.298	1.298	1.298	1.298	1.009	1.009	1.009	1.009	POA	
9/16	16	1.68	3530-9/16X3.0D	–	–	1.511	1.511	1.511	1.511	1.511	1.511	1.511	1.272	1.272	1.272	1.272	POA	
5/8	14	1.89	3530-5/8X3.0D	–	–	1.916	1.916	1.916	1.916	1.916	1.916	1.916	1.613	1.613	1.613	1.613	POA	
3/4	12	2.25	3530-3/4X3.0D	–	–	2.565	2.565	2.565	2.565	2.565	2.565	2.565	2.160	2.160	2.160	2.160	POA	
7/8	11	2.64	3530-7/8X3.0D	–	–	3.276	3.276	3.276	3.276	3.276	3.276	3.276	2.955	2.955	2.955	2.955	POA	
1	10	3.00	3530-1X3.0D	–	–	4.201	4.201	4.201	4.201	4.201	4.201	4.201	3.790	3.790	3.790	3.790	POA	



BSP
1.0D, 1.5D, 2.0D



GROUP	PCWI
INSERT TYPE	WIRE THREAD
INSERT MATERIAL	304 STAINLESS STEEL
STYLE	FREE RUNNING

BSP – 1.0D BULK INSERTS

D	TPI	INCH	PART #	1.0D													
				€ EACH	€ EACH	€ EACH	€ EACH	€ EACH	€ EACH	€ EACH	€ EACH	€ EACH	€ EACH	€ EACH	€ EACH	€ EACH	
INCH	TPI	INCH	PART #	1	3	5	10	50	100	250	500	1000	5000	10000	100K+		
1/8	28	0.13	3546-1/8X1.0D	-	-	0.490	0.490	0.490	0.490	0.490	0.490	0.490	0.442	0.442	0.442	0.442	POA
1/4	19	0.25	3546-1/4X1.0D	-	-	0.696	0.696	0.696	0.696	0.696	0.696	0.696	0.628	0.628	0.628	0.628	POA
3/8	19	0.38	3546-3/8X1.0D	-	-	0.703	0.703	0.703	0.703	0.703	0.703	0.703	0.634	0.634	0.634	0.634	POA
1/2	14	0.50	3546-1/2X1.0D	-	-	1.376	1.376	1.376	1.376	1.376	1.376	1.376	1.242	1.242	1.242	1.242	POA
5/8	14	0.63	3546-5/8X1.0D	-	-	2.065	2.065	2.065	2.065	2.065	2.065	2.065	1.862	1.862	1.862	1.862	POA
3/4	14	0.75	3546-3/4X1.0D	-	-	2.065	2.065	2.065	2.065	2.065	2.065	2.065	1.862	1.862	1.862	1.862	POA
7/8	14	0.88	3546-7/8X1.0D	-	-	2.706	2.706	2.706	2.706	2.706	2.706	2.706	2.706	2.706	2.706	2.706	POA
1	11	1.00	3546-1X1.0D	-	-	2.602	2.602	2.602	2.602	2.602	2.602	2.602	2.347	2.347	2.347	2.347	POA

BSP – 1.5D BULK INSERTS

D	TPI	INCH	PART #	1.5D													
				€ EACH	€ EACH	€ EACH	€ EACH	€ EACH	€ EACH	€ EACH	€ EACH	€ EACH	€ EACH	€ EACH	€ EACH	€ EACH	
INCH	TPI	INCH	PART #	1	3	5	10	50	100	250	500	1000	5000	10000	100K+		
1/8	28	0.20	3546-1/8X1.5D	-	-	0.587	0.587	0.587	0.587	0.587	0.587	0.587	0.529	0.529	0.529	0.529	POA
1/4	19	0.38	3546-1/4X1.5D	-	-	0.847	0.847	0.847	0.847	0.847	0.847	0.847	0.764	0.764	0.764	0.764	POA
3/8	19	0.57	3546-3/8X1.5D	-	-	1.074	1.074	1.074	1.074	1.074	1.074	1.074	0.969	0.969	0.969	0.969	POA
1/2	14	0.75	3546-1/2X1.5D	-	-	1.755	1.755	1.755	1.755	1.755	1.755	1.755	1.583	1.583	1.583	1.583	POA
5/8	14	0.95	3546-5/8X1.5D	-	-	2.526	2.526	2.526	2.526	2.526	2.526	2.526	2.279	2.279	2.279	2.279	POA
3/4	14	1.13	3546-3/4X1.5D	-	-	2.526	2.526	2.526	2.526	2.526	2.526	2.526	2.279	2.279	2.279	2.279	POA
7/8	14	1.32	3546-7/8X1.5D	-	-	3.570	3.570	3.570	3.570	3.570	3.570	3.570	3.570	3.570	3.570	3.570	POA
1	11	1.50	3546-1X1.5D	-	-	3.388	3.388	3.388	3.388	3.388	3.388	3.388	3.056	3.056	3.056	3.056	POA

BSP – 2.0D BULK INSERTS

D	TPI	INCH	PART #	2.0D													
				€ EACH	€ EACH	€ EACH	€ EACH	€ EACH	€ EACH	€ EACH	€ EACH	€ EACH	€ EACH	€ EACH	€ EACH	€ EACH	
INCH	TPI	INCH	PART #	1	3	5	10	50	100	250	500	1000	5000	10000	100K+		
1/8	28	0.26	3546-1/8X2.0D	-	-	0.779	0.779	0.779	0.779	0.779	0.779	0.779	0.703	0.703	0.703	0.703	POA
1/4	19	0.50	3546-1/4X2.0D	-	-	1.142	1.142	1.142	1.142	1.142	1.142	1.142	1.030	1.030	1.030	1.030	POA
3/8	19	0.76	3546-3/8X2.0D	-	-	1.460	1.460	1.460	1.460	1.460	1.460	1.460	1.317	1.317	1.317	1.317	POA
1/2	14	1.00	3546-1/2X2.0D	-	-	2.231	2.231	2.231	2.231	2.231	2.231	2.231	2.012	2.012	2.012	2.012	POA
5/8	14	1.26	3546-5/8X2.0D	-	-	3.169	3.169	3.169	3.169	3.169	3.169	3.169	2.858	2.858	2.858	2.858	POA
3/4	14	1.50	3546-3/4X2.0D	-	-	3.169	3.169	3.169	3.169	3.169	3.169	3.169	2.858	2.858	2.858	2.858	POA
7/8	14	1.76	3546-7/8X2.0D	-	-	5.935	5.935	5.935	5.935	5.935	5.935	5.935	5.935	5.935	5.935	5.935	POA
1	11	2.00	3546-1X2.0D	-	-	4.114	4.114	4.114	4.114	4.114	4.114	4.114	3.711	3.711	3.711	3.711	POA





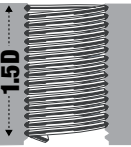

NPT



GROUP	PCWI
INSERT TYPE	WIRE THREAD
INSERT MATERIAL	304 STAINLESS STEEL
STYLE	FREE RUNNING

NPT – 1.5D BULK INSERTS

 INCH INCH	 TPI TPI	 INCH INCH	 PART # PART #			€	€	€	€	€	€	€	€	€	€	€	€	
				1	3	5	10	50	100	250	500	1000	5000	10000	100K+			
1/16	27	0.095	3552-1/16X1.5D	–	–	0.587	0.587	0.587	0.587	0.587	0.587	0.587	0.587	0.529	0.529	0.529	0.529	POA
1/8	27	0.188	3552-1/8X1.5D	–	–	0.587	0.587	0.587	0.587	0.587	0.587	0.587	0.587	0.529	0.529	0.529	0.529	POA
1/4	18	0.375	3552-1/4X1.5D	–	–	0.847	0.847	0.847	0.847	0.847	0.847	0.847	0.847	0.764	0.764	0.764	0.764	POA
3/8	18	0.563	3552-3/8X1.5D	–	–	1.074	1.074	1.074	1.074	1.074	1.074	1.074	1.074	0.969	0.969	0.969	0.969	POA
1/2	14	0.750	3552-1/2X1.5D	–	–	1.755	1.755	1.755	1.755	1.755	1.755	1.755	1.755	1.583	1.583	1.583	1.583	POA
3/4	14	1.125	3552-3/4X1.5D	–	–	2.526	2.526	2.526	2.526	2.526	2.526	2.526	2.526	2.279	2.279	2.279	2.279	POA
1	11.5	1.500	3552-1X1.5D	–	–	3.388	3.388	3.388	3.388	3.388	3.388	3.388	3.388	3.056	3.056	3.056	3.056	POA





8-UN

1.0D, 1.5D, 2.0D





GROUP	PCWI
INSERT TYPE	WIRE THREAD
INSERT MATERIAL	304 STAINLESS STEEL
STYLE	FREE RUNNING



8-UN – 1.0D BULK INSERTS

 8-UN	 1.0D	INCH	TPI	INCH	PART #	€ EACH																
						1	3	5	10	50	100	250	500	1000	5000	10000	100K+					
1-1/8	8	1.13	8	3570-1.1/8X1.0D	-	-	3.942	3.942	3.942	3.942	3.942	3.942	3.942	3.942	3.942	3.942	3.942	3.942	3.942	3.942	POA	
1-1/4	8	1.25	8	3570-1.1/4X1.0D	-	-	4.719	4.719	4.719	4.719	4.719	4.719	4.719	4.719	4.719	4.719	4.719	4.719	4.719	4.719	4.719	POA
1-3/8	8	1.38	8	3570-1.3/8X1.0D	-	-	5.332	5.332	5.332	5.332	5.332	5.332	5.332	5.332	5.332	5.332	5.332	5.332	5.332	5.332	5.332	POA
1-1/2	8	1.50	8	3570-1.1/2X1.0D	-	-	5.950	5.950	5.950	5.950	5.950	5.950	5.950	5.950	5.950	5.950	5.950	5.950	5.950	5.950	5.950	POA
1-5/8	8	1.63	8	3570-1.5/8X1.0D	-	-	6.512	6.512	6.512	6.512	6.512	6.512	6.512	6.512	6.512	6.512	6.512	6.512	6.512	6.512	6.512	POA
1-3/4	8	1.75	8	3570-1.3/4X1.0D	-	-	7.061	7.061	7.061	7.061	7.061	7.061	7.061	7.061	7.061	7.061	7.061	7.061	7.061	7.061	7.061	POA
1-7/8	8	1.88	8	3570-1.7/8X1.0D	-	-	7.624	7.624	7.624	7.624	7.624	7.624	7.624	7.624	7.624	7.624	7.624	7.624	7.624	7.624	7.624	POA
2	8	2.00	8	3570-2X1.0D	-	-	8.160	8.160	8.160	8.160	8.160	8.160	8.160	8.160	8.160	8.160	8.160	8.160	8.160	8.160	8.160	POA

8-UN – 1.5D BULK INSERTS

 8-UN	 1.5D	INCH	TPI	INCH	PART #	€ EACH																	
						1	3	5	10	50	100	250	500	1000	5000	10000	100K+						
1-1/8	8	1.69	8	3570-1.1/8X1.5D	-	-	4.643	4.643	4.643	4.643	4.643	4.643	4.643	4.643	4.643	4.643	4.643	4.643	4.643	4.643	4.643	POA	
1-1/4	8	1.88	8	3570-1.1/4X1.5D	-	-	5.701	5.701	5.701	5.701	5.701	5.701	5.701	5.701	5.701	5.701	5.701	5.701	5.701	5.701	5.701	5.701	POA
1-3/8	8	2.06	8	3570-1.3/8X1.5D	-	-	7.086	7.086	7.086	7.086	7.086	7.086	7.086	7.086	7.086	7.086	7.086	7.086	7.086	7.086	7.086	7.086	POA
1-1/2	8	2.25	8	3570-1.1/2X1.5D	-	-	7.897	7.897	7.897	7.897	7.897	7.897	7.897	7.897	7.897	7.897	7.897	7.897	7.897	7.897	7.897	7.897	POA
1-5/8	8	2.44	8	3570-1.5/8X1.5D	-	-	8.378	8.378	8.378	8.378	8.378	8.378	8.378	8.378	8.378	8.378	8.378	8.378	8.378	8.378	8.378	8.378	POA
1-3/4	8	2.63	8	3570-1.3/4X1.5D	-	-	9.100	9.100	9.100	9.100	9.100	9.100	9.100	9.100	9.100	9.100	9.100	9.100	9.100	9.100	9.100	9.100	POA
1-7/8	8	2.81	8	3570-1.7/8X1.5D	-	-	9.763	9.763	9.763	9.763	9.763	9.763	9.763	9.763	9.763	9.763	9.763	9.763	9.763	9.763	9.763	9.763	POA
2	8	3.00	8	3570-2X1.5D	-	-	10.484	10.484	10.484	10.484	10.484	10.484	10.484	10.484	10.484	10.484	10.484	10.484	10.484	10.484	10.484	10.484	POA

8-UN – 2.0D BULK INSERTS

 8-UN	 2.0D	INCH	TPI	INCH	PART #	€ EACH																	
						1	3	5	10	50	100	250	500	1000	5000	10000	100K+						
1-1/8	8	2.25	8	3570-1.1/8X2.0D	-	-	4.958	4.958	4.958	4.958	4.958	4.958	4.958	4.958	4.958	4.958	4.958	4.958	4.958	4.958	4.958	4.958	POA
1-1/4	8	2.50	8	3570-1.1/4X2.0D	-	-	6.450	6.450	6.450	6.450	6.450	6.450	6.450	6.450	6.450	6.450	6.450	6.450	6.450	6.450	6.450	6.450	POA
1-3/8	8	2.75	8	3570-1.3/8X2.0D	-	-	7.799	7.799	7.799	7.799	7.799	7.799	7.799	7.799	7.799	7.799	7.799	7.799	7.799	7.799	7.799	7.799	POA
1-1/2	8	3.00	8	3570-1.1/2X2.0D	-	-	9.260	9.260	9.260	9.260	9.260	9.260	9.260	9.260	9.260	9.260	9.260	9.260	9.260	9.260	9.260	9.260	POA
1-5/8	8	3.25	8	3570-1.5/8X2.0D	-	-	10.325	10.325	10.325	10.325	10.325	10.325	10.325	10.325	10.325	10.325	10.325	10.325	10.325	10.325	10.325	10.325	POA
1-3/4	8	3.50	8	3570-1.3/4X2.0D	-	-	10.466	10.466	10.466	10.466	10.466	10.466	10.466	10.466	10.466	10.466	10.466	10.466	10.466	10.466	10.466	10.466	POA
1-7/8	8	3.75	8	3570-1.7/8X2.0D	-	-	12.053	12.053	12.053	12.053	12.053	12.053	12.053	12.053	12.053	12.053	12.053	12.053	12.053	12.053	12.053	12.053	POA
2	8	4.00	8	3570-2X2.0D	-	-	12.911	12.911	12.911	12.911	12.911	12.911	12.911	12.911	12.911	12.911	12.911	12.911	12.911	12.911	12.911	12.911	POA



**BA
BSC**

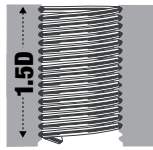

GROUP	PCWI
INSERT TYPE	WIRE THREAD
INSERT MATERIAL	304 STAINLESS STEEL
STYLE	FREE RUNNING

BA – 1.5D BULK INSERTS

				1.5D			€	€	€	€	€	€	€	€	€	€	€	€	
					EACH	EACH	EACH	EACH	EACH	EACH	EACH	EACH	EACH	EACH	EACH	EACH	EACH	EACH	EACH
INCH	INCH	PART #			1	3	5	10	50	100	250	500	1000	5000	10000	100K+			
0	0.0394	0.24	3544-0X1.5D	–	–	1.758	1.758	1.758	1.758	1.758	1.758	1.758	1.494	1.494	1.494	POA	POA		
2	0.0319	0.19	3544-2X1.5D	–	–	0.583	0.583	0.583	0.583	0.583	0.583	0.583	0.495	0.495	0.495	POA	POA		
4	0.0260	0.14	3544-4X1.5D	–	–	0.583	0.583	0.583	0.583	0.583	0.583	0.583	0.495	0.495	0.495	POA	POA		
6	0.0209	0.11	3544-6X1.5D	–	–	0.583	0.583	0.583	0.583	0.583	0.583	0.583	0.495	0.495	0.495	POA	POA		



BSC(B) – 1.5D BULK INSERTS

				1.5D			€	€	€	€	€	€	€	€	€	€	€	€	
					EACH	EACH	EACH	EACH	EACH	EACH	EACH	EACH	EACH	EACH	EACH	EACH	EACH	EACH	EACH
INCH	TPI	INCH	PART #	1	3	5	10	50	100	250	500	1000	5000	10000	100K+				
1/4	26	0.38	3560-1/4X1.5D	–	–	1.122	1.122	1.122	1.122	1.122	1.122	1.122	1.122	1.122	1.122	POA	POA		
5/16	26	0.47	3560-5/16X1.5D	–	–	0.442	0.442	0.442	0.442	0.442	0.442	0.442	0.442	0.442	0.442	POA	POA		
3/8	26	0.56	3560-3/8X1.5D	–	–	0.513	0.513	0.513	0.513	0.513	0.513	0.513	0.513	0.513	0.513	POA	POA		
7/16	26	0.66	3560-7/16x1.5D	–	–	0.692	0.692	0.692	0.692	0.692	0.692	0.692	0.692	0.692	0.692	POA	POA		
1/2	26	0.75	3560-1/2X1.5D	–	–	1.168	1.168	1.168	1.168	1.168	1.168	1.168	1.168	1.168	1.168	POA	POA		

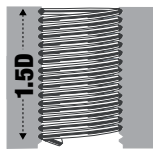



GROUP	PCIR
INSERT TYPE	WIRE THREAD
INSERT MATERIAL	304 STAINLESS STEEL
STYLE	FREE RUNNING

METRIC

D	MM	MM	INSTALLED LENGTH	#	€	1.0D		1.5D		2.0D	
						€	PART #	€	PART #	€	PART #
2.20	0.45	1.0D	2.20MM	1000	0.224	3520-2.20X1.0DIR	-	-	-	-	
2.20	0.45	1.5D	3.30MM	1000	-	-	0.239	3520-2.20X1.5DIR	-	-	
2.20	0.45	2.0D	4.40MM	1000	-	-	-	-	0.252	3520-2.20X2.0DIR	
2.50	0.45	1.0D	2.50MM	1000	0.204	3520-2.50X1.0DIR	-	-	-	-	
2.50	0.45	1.5D	3.75MM	1000	-	-	0.217	3520-2.50X1.5DIR	-	-	
2.50	0.45	2.0D	5.00MM	1000	-	-	-	-	0.229	3520-2.50X2.0DIR	
3.00	0.50	1.0D	3.00MM	1000	0.204	3520-3.00X1.0DIR	-	-	-	-	
3.00	0.50	1.5D	4.50MM	1000	-	-	0.217	3520-3.00X1.5DIR	-	-	
3.00	0.50	2.0D	6.00MM	1000	-	-	-	-	0.229	3520-3.00X2.0DIR	
4.00	0.70	1.0D	4.00MM	1000	0.204	3520-4.00X1.0DIR	-	-	-	-	
4.00	0.70	1.5D	6.00MM	1000	-	-	0.217	3520-4.00X1.5DIR	-	-	
4.00	0.70	2.0D	8.00MM	1000	-	-	-	-	0.229	3520-4.00X2.0DIR	
5.00	0.80	1.0D	5.00MM	1000	0.204	3520-5.00X1.0DIR	-	-	-	-	
5.00	0.80	1.5D	7.50MM	1000	-	-	0.217	3520-5.00X1.5DIR	-	-	
5.00	0.80	2.0D	10.00MM	1000	-	-	-	-	0.229	3520-5.00X2.0DIR	
6.00	1.00	1.0D	6.00MM	500	0.204	3520-6.00X1.0DIR	-	-	-	-	
6.00	1.00	1.5D	9.00MM	500	-	-	0.217	3520-6.00X1.5DIR	-	-	
6.00	1.00	2.0D	12.00MM	500	-	-	-	-	0.229	3520-6.00X2.0DIR	
8.00	1.00	1.0D	8.00MM	250	0.229	3521-8.00X1.0DIR	-	-	-	-	
8.00	1.00	1.5D	12.00MM	250	-	-	0.269	3521-8.00X1.5DIR	-	-	
8.00	1.00	2.0D	16.00MM	250	-	-	-	-	0.325	3521-8.00X2.0DIR	
8.00	1.25	1.0D	8.00MM	250	0.229	3520-8.00X1.0DIR	-	-	-	-	
8.00	1.25	1.5D	12.00MM	250	-	-	0.269	3520-8.00X1.5DIR	-	-	
8.00	1.25	2.0D	16.00MM	250	-	-	-	-	0.325	3520-8.00X2.0DIR	
10.00	1.50	1.0D	10.00MM	250	0.262	3520-10.00X1.0DIR	-	-	-	-	
10.00	1.50	1.5D	15.00MM	250	-	-	0.312	3520-10.00X1.5DIR	-	-	
10.00	1.50	2.0D	20.00MM	250	-	-	-	-	0.414	3520-10.00X2.0DIR	
12.00	1.75	1.0D	12.00MM	125	0.336	3520-12.00X1.0DIR	-	-	-	-	
12.00	1.75	1.5D	18.00MM	125	-	-	0.515	3520-12.00X1.5DIR	-	-	
12.00	1.75	2.0D	24.00MM	125	-	-	-	-	0.693	3520-12.00X2.0DIR	

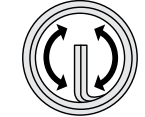



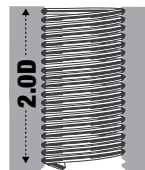
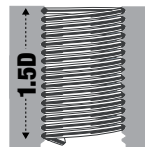





MC
MF



GROUP	PCIR
INSERT TYPE	WIRE THREAD
INSERT MATERIAL	304 STAINLESS STEEL
STYLE	FREE RUNNING



UNC										
						1.0D		1.5D		2.0D
INCH	TPI	INSTALLED LENGTH		#	€	PART #	€	PART #	€	PART #
2G	56	1.0D	0.09"	1000	0.274	3532-2GX1.0DIR	-	-	-	-
2G	56	1.5D	0.13"	1000	-	-	0.292	3532-2GX1.5DIR	-	-
2G	56	2.0D	0.17"	1000	-	-	-	-	0.306	3532-2GX2.0DIR
4G	40	1.0D	0.11"	1000	0.215	3532-4GX1.0DIR	-	-	-	-
4G	40	1.5D	0.17"	1000	-	-	0.229	3532-4GX1.5DIR	-	-
4G	40	2.0D	0.22"	1000	-	-	-	-	0.203	3532-4GX2.0DIR
5G	40	1.0D	0.13"	1000	0.241	3532-5GX1.0DIR	-	-	-	-
5G	40	1.5D	0.19"	1000	-	-	0.282	3532-5GX1.5DIR	-	-
5G	40	2.0D	0.25"	1000	-	-	-	-	0.343	3532-5GX2.0DIR
6G	32	1.0D	0.14"	1000	0.215	3532-6GX1.0DIR	-	-	-	-
6G	32	1.5D	0.21"	1000	-	-	0.229	3532-6GX1.5DIR	-	-
6G	32	2.0D	0.28"	1000	-	-	-	-	0.241	3532-6GX2.0DIR
8G	32	1.0D	0.16"	1000	0.215	3532-8GX1.0DIR	-	-	-	-
8G	32	1.5D	0.25"	1000	-	-	0.229	3532-8GX1.5DIR	-	-
8G	32	2.0D	0.33"	1000	-	-	-	-	0.241	3532-8GX2.0DIR
10G	24	1.0D	0.19"	1000	0.215	3532-10GX1.0DIR	-	-	-	-
10G	24	1.5D	0.29"	1000	-	-	0.229	3532-10GX1.5DIR	-	-
10G	24	2.0D	0.38"	1000	-	-	-	-	0.241	3532-10GX2.0DIR
12G	24	1.0D	0.22"	500	0.236	3532-12GX1.0DIR	-	-	-	-
12G	24	1.5D	0.32"	500	-	-	0.252	3532-12GX1.5DIR	-	-
12G	24	2.0D	0.43"	500	-	-	-	-	0.265	3532-12GX2.0DIR
1/4	20	1.0D	0.25"	500	0.215	3532-1/4X1.0DIR	-	-	-	-
1/4	20	1.5D	0.38"	500	-	-	0.229	3532-1/4X1.5DIR	-	-
1/4	20	2.0D	0.50"	500	-	-	-	-	0.241	3532-1/4X2.0DIR
5/16	18	1.0D	0.31"	250	0.241	3532-5/16X1.0DIR	-	-	-	-
5/16	18	1.5D	0.47"	250	-	-	0.282	3532-5/16X1.5DIR	-	-
5/16	18	2.0D	0.62"	250	-	-	-	-	0.343	3532-5/16X2.0DIR
3/8	16	1.0D	0.38"	250	0.275	3532-3/8X1.0DIR	-	-	-	-
3/8	16	1.5D	0.57"	250	-	-	0.329	3532-3/8X1.5DIR	-	-
3/8	16	2.0D	0.76"	250	-	-	-	-	0.436	3532-3/8X2.0DIR
UNF										
4G	48	1.0D	0.11"	1000	0.215	3534-4GX1.0DIR	-	-	-	-
4G	48	1.5D	0.17"	1000	-	-	0.229	3534-4GX1.5DIR	-	-
4G	48	2.0D	0.22"	1000	-	-	-	-	0.241	3534-4GX2.0DIR
6G	40	1.0D	0.14"	1000	0.215	3534-6GX1.0DIR	-	-	-	-
6G	40	1.5D	0.21"	1000	-	-	0.229	3534-6GX1.5DIR	-	-
6G	40	2.0D	0.28"	1000	-	-	-	-	0.241	3534-6GX2.0DIR
8G	36	1.0D	0.16"	1000	0.215	3534-8GX1.0DIR	-	-	-	-
8G	36	1.5D	0.25"	1000	-	-	0.229	3534-8GX1.5DIR	-	-
8G	36	2.0D	0.33"	1000	-	-	-	-	0.241	3534-8GX2.0DIR
10G	32	1.0D	0.19"	1000	0.215	3534-10GX1.0DIR	-	-	-	-
10G	32	1.5D	0.29"	1000	-	-	0.229	3534-10GX1.5DIR	-	-
10G	32	2.0D	0.38"	1000	-	-	-	-	0.241	3534-10GX2.0DIR
1/4	28	1.0D	0.25"	500	0.215	3534-1/4X1.0DIR	-	-	-	-
1/4	28	1.5D	0.38"	500	-	-	0.229	3534-1/4X1.5DIR	-	-
1/4	28	2.0D	0.50"	500	-	-	-	-	0.241	3534-1/4X2.0DIR
5/16	24	1.0D	0.31"	250	0.241	3534-5/16X1.0DIR	-	-	-	-
5/16	24	1.5D	0.47"	250	-	-	0.282	3534-5/16X1.5DIR	-	-
5/16	24	2.0D	0.62"	250	-	-	-	-	0.343	3534-5/16X2.0DIR
3/8	24	1.0D	0.38"	250	0.275	3534-3/8X1.0DIR	-	-	-	-
3/8	24	1.5D	0.57"	250	-	-	0.329	3534-3/8X1.5DIR	-	-
3/8	24	2.0D	0.76"	250	-	-	-	-	0.436	3534-3/8X2.0DIR





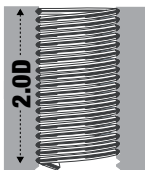
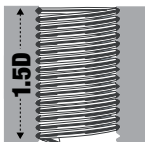





**UNC
UNF**





GROUP	PCTP	PCTP
MATERIAL	HSS	HSSE
TOLERANCE	4H5H	4H5H
TYPE	STI	STI

METRIC COARSE – STI TAPS

									
								MM	MM
2.00	0.40	44.50	17.85	3520-2.00T	3520-2.00I	3520-2.00B	21.42	3520-2.00SP	3520-2.00SF
2.20	0.45	44.50	17.85	3520-2.20T	3520-2.20I	3520-2.20B	21.42	3520-2.20SP	3520-2.20SF
2.50	0.45	48.00	17.85	3520-2.50T	3520-2.50I	3520-2.50B	21.42	3520-2.50SP	3520-2.50SF
3.00	0.50	53.00	16.07	3520-3.00T	3520-3.00I	3520-3.00B	18.48	3520-3.00SP	3520-3.00SF
3.50	0.60	53.00	16.07	3520-3.50T	3520-3.50I	3520-3.50B	18.48	3520-3.50SP	3520-3.50SF
4.00	0.70	58.00	15.44	3520-4.00T	3520-4.00I	3520-4.00B	17.85	3520-4.00SP	3520-4.00SF
5.00	0.80	66.00	16.07	3520-5.00T	3520-5.00I	3520-5.00B	19.01	3520-5.00SP	3520-5.00SF
6.00	1.00	72.00	15.75	3520-6.00T	3520-6.00I	3520-6.00B	18.38	3520-6.00SP	3520-6.00SF
7.00	1.00	72.00	19.01	3520-7.00T	3520-7.00I	3520-7.00B	23.73	3520-7.00SP	3520-7.00SF
8.00	1.25	80.00	19.64	3520-8.00T	3520-8.00I	3520-8.00B	22.58	3520-8.00SP	3520-8.00SF
9.00	1.25	85.00	24.89	3520-9.00T	3520-9.00I	3520-9.00B	–	–	–
10.00	1.50	89.00	23.73	3520-10.00T	3520-10.00I	3520-10.00B	28.56	3520-10.00SP	3520-10.00SF
11.00	1.50	89.00	26.99	3520-11.00T	3520-11.00I	3520-11.00B	32.45	3520-11.00SP	3520-11.00SF
12.00	1.75	95.00	26.15	3520-12.00T	3520-12.00I	3520-12.00B	33.29	3520-12.00SP	3520-12.00SF
13.00	1.75	95.00	29.93	3520-13.00T	3520-13.00I	3520-13.00B	–	–	–
14.00	2.00	102.00	38.54	3520-14.00T	3520-14.00I	3520-14.00B	51.03	3520-14.00SP	3520-14.00SF
15.00	2.00	112.00	42.95	3520-15.00T	3520-15.00I	3520-15.00B	–	–	–
16.00	2.00	112.00	47.25	3520-16.00T	3520-16.00I	3520-16.00B	54.60	3520-16.00SP	3520-16.00SF
18.00	2.50	118.00	52.71	3520-18.00T	3520-18.00I	3520-18.00B	71.19	3520-18.00SP	3520-18.00SF
20.00	2.50	118.00	60.59	3520-20.00T	3520-20.00I	3520-20.00B	83.90	3520-20.00SP	3520-20.00SF
22.00	2.50	130.00	67.73	3520-22.00T	3520-22.00I	3520-22.00B	118.65	3520-22.00SP	3520-22.00SF
24.00	3.00	138.00	91.46	3520-24.00T	3520-24.00I	3520-24.00B	142.38	3520-24.00SP	3520-24.00SF
27.00	3.00	151.00	160.23	–	3520-27.00I	–	–	–	–
30.00	3.50	162.00	190.58	–	3520-30.00I	–	238.22	3520-30.00SP	3520-30.00SF
33.00	3.50	162.00	190.58	–	3520-33.00I	–	238.22	3520-33.00SP	3520-33.00SF
36.00	4.00	170.00	266.07	–	3520-36.00I	–	–	–	–

GROUP	PCTP	PCTP
MATERIAL	HSS	HSSE
TOLERANCE	4H5H	4H5H
TYPE	STI	STI

METRIC FINE – STI TAPS

MM	MM	MM	€	PART #	PART #	PART #	€	PART #	PART #	PART #	
8.00	1.00	80.00	19.64	3521-8.00T	3521-8.00I	3521-8.00B	22.58	3521-8.00SP	3521-8.00SF		
10.00	1.25	85.00	23.73	3521-10.00T	3521-10.00I	3521-10.00B	28.56	3521-10.00SP	3521-10.00SF		
10.00	1.00	85.00	23.73	3523-10.00T	3523-10.00I	3523-10.00B	28.56	3523-10.00SP	3523-10.00SF		
11.00	1.25	88.00	26.99	3521-11.00T	3521-11.00I	3521-11.00B	-	-	-		
11.00	1.00	88.00	26.99	3523-11.00T	3523-11.00I	3523-11.00B	-	-	-		
12.00	1.50	95.00	26.15	3521-12.00T	3521-12.00I	3521-12.00B	33.29	3521-12.00SP	3521-12.00SF		
12.00	1.25	95.00	26.15	3523-12.00T	3523-12.00I	3523-12.00B	33.29	3523-12.00SP	3523-12.00SF		
12.00	1.00	95.00	26.15	3524-12.00T	3524-12.00I	3524-12.00B	-	-	-		
13.00	1.25	95.00	29.93	3523-13.00T	3523-13.00I	3523-13.00B	-	-	-		
14.00	1.50	102.00	38.54	3521-14.00T	3521-14.00I	3521-14.00B	51.03	3521-14.00SP	3521-14.00SF		
14.00	1.25	102.00	38.54	3523-14.00T	3523-14.00I	3523-14.00B	51.03	3523-14.00SP	3523-14.00SF		
14.00	1.00	102.00	38.54	3524-14.00T	3524-14.00I	3524-14.00B	-	-	-		
15.00	1.50	104.00	42.95	3521-15.00T	3521-15.00I	3521-15.00B	-	-	-		
16.00	1.50	104.00	47.25	3521-16.00T	3521-16.00I	3521-16.00B	-	-	-		
18.00	2.00	104.00	52.71	3521-18.00T	3521-18.00I	3521-18.00B	-	-	-		
18.00	1.50	104.00	52.71	3523-18.00T	3523-18.00I	3523-18.00B	-	-	-		
20.00	2.00	113.00	60.59	3521-20.00T	3521-20.00I	3521-20.00B	-	-	-		
20.00	1.50	113.00	60.59	3523-20.00T	3523-20.00I	3523-20.00B	-	-	-		
22.00	2.00	120.00	67.73	3521-22.00T	3521-22.00I	3521-22.00B	-	-	-		
22.00	1.50	120.00	67.73	3523-22.00T	3523-22.00I	3523-22.00B	-	-	-		
24.00	2.00	127.00	91.46	3521-24.00T	3521-24.00I	3521-24.00B	-	-	-		
24.00	1.50	127.00	91.46	3523-24.00T	3523-24.00I	3523-24.00B	-	-	-		
26.00	1.50	127.00	135.87	3523-26.00T	3523-26.00I	3523-26.00B	-	-	-		
27.00	2.00	127.00	160.23	3521-27.00T	3521-27.00I	3521-27.00B	-	-	-		
27.00	1.50	127.00	160.23	3523-27.00T	3523-27.00I	3523-27.00B	-	-	-		
28.00	1.50	127.00	178.61	3523-28.00T	3523-28.00I	3523-28.00B	-	-	-		
30.00	2.00	137.00	190.58	3521-30.00T	3521-30.00I	3521-30.00B	-	-	-		
30.00	1.50	137.00	190.58	3523-30.00T	3523-30.00I	3523-30.00B	-	-	-		
33.00	2.00	144.00	231.42	3521-33.00T	3521-33.00I	3521-33.00B	-	-	-		
36.00	3.00	170.00	266.07	3521-36.00T	3521-36.00I	3521-36.00B	-	-	-		
36.00	2.00	150.00	266.07	3523-36.00T	3523-36.00I	3523-36.00B	-	-	-		
36.00	1.50	150.00	266.07	3524-36.00T	3524-36.00I	3524-36.00B	-	-	-		

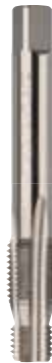

SPARK PLUG – PILOT NOSE STI TAPS

MM	MM	MM	€	PART #			
6.00	1.00	70.00	26.25	3520-6.00PN			
8.00	1.25	75.00	31.50	3520-8.00PN			
10.00	1.50	80.00	35.60	3520-10.00PN			
10.00	1.00	74.00	39.17	3522-10.00PN			
12.00	1.25	75.00	47.46	3522-12.00PN			
14.00	1.25	90.00	53.45	3522-14.00PN			
18.00	1.50	116.00	89.04	3522-18.00PN			





GROUP	PCTP	PCTP
MATERIAL	HSS	HSSE
TOLERANCE	3B	3B
TYPE	STI	STI

UNC – STI TAPS

INCH	TPI	MM	€	PART #	PART #	PART #	€	PART #	PART #		
2G	56	48.00	22.58	3532-2GT	3532-2GI	3532-2GB	28.56	3532-2GSP	3532-2GSF		
3G	48	48.00	37.63	3532-3GT	3532-3GI	3532-3GB	45.15	3532-3GSP	3532-3GSF		
4G	40	53.00	22.58	3532-4GT	3532-4GI	3532-4GB	28.56	3532-4GSP	3532-4GSF		
5G	40	53.00	22.58	3532-5GT	3532-5GI	3532-5GB	28.56	3532-5GSP	3532-5GSF		
6G	32	58.00	22.58	3532-6GT	3532-6GI	3532-6GB	28.56	3532-6GSP	3532-6GSF		
8G	32	62.00	22.58	3532-8GT	3532-8GI	3532-8GB	28.56	3532-8GSP	3532-8GSF		
10G	24	66.00	19.01	3532-10GT	3532-10GI	3532-10GB	26.15	3532-10GSP	3532-10GSF		
12G	24	66.00	19.01	3532-12GT	3532-12GI	3532-12GB	26.15	3532-12GSP	3532-12GSF		
1/4	20	72.00	16.70	3532-1/4T	3532-1/4I	3532-1/4B	19.01	3532-1/4SP	3532-1/4SF		
5/16	18	80.00	19.64	3532-5/16T	3532-5/16I	3532-5/16B	22.58	3532-5/16SP	3532-5/16SF		
3/8	16	85.00	23.73	3532-3/8T	3532-3/8I	3532-3/8B	28.56	3532-3/8SP	3532-3/8SF		
7/16	14	95.00	26.99	3532-7/16T	3532-7/16I	3532-7/16B	32.45	3532-7/16SP	3532-7/16SF		
1/2	13	102.00	27.30	3532-1/2T	3532-1/2I	3532-1/2B	35.60	3532-1/2SP	3532-1/2SF		
9/16	12	112.00	44.52	3532-9/16T	3532-9/16I	3532-9/16B	–	–	–		
5/8	11	112.00	56.28	3532-5/8T	3532-5/8I	3532-5/8B	82.74	3532-5/8SP	3532-5/8SF		
3/4	10	118.00	70.98	3532-3/4T	3532-3/4I	3532-3/4B	83.90	3532-3/4SP	3532-3/4SF		
7/8	9	130.00	83.06	3532-7/8T	3532-7/8I	3532-7/8B	121.70	3532-7/8SP	3532-7/8SF		
1	8	138.00	91.46	3532-1T	3532-1I	3532-1B	142.38	3532-1SP	3532-1SF		
1-1/8	7	151.00	168.53	3532-1.1/8T	3532-1.1/8I	3532-1.1/8B	–	–	–		
1-1/4	7	162.00	177.98	3532-1.1/4T	3532-1.1/4I	3532-1.1/4B	–	–	–		
1-3/8	6	170.00	219.56	3532-1.3/8T	3532-1.3/8I	3532-1.3/8B	–	–	–		
1-1/2	6	187.00	266.07	3532-1.1/2T	3532-1.1/2I	3532-1.1/2B	–	–	–		

UNF – STI TAPS

INCH	TPI	MM	€	PART #	PART #	PART #	€	PART #	PART #		
3G	56	48.00	22.58	3534-3GT	3534-3GI	3534-3GB	28.56	3534-3GSP	3534-3GSF		
4G	48	53.00	22.58	3534-4GT	3534-4GI	3534-4GB	28.56	3534-4GSP	3534-4GSF		
6G	40	53.00	22.58	3534-6GT	3534-6GI	3534-6GB	28.56	3534-6GSP	3534-6GSF		
8G	36	62.00	22.58	3534-8GT	3534-8GI	3534-8GB	28.56	3534-8GSP	3534-8GSF		
10G	32	66.00	19.01	3534-10GT	3534-10GI	3534-10GB	26.15	3534-10GSP	3534-10GSF		
12G	28	66.00	19.01	3534-12GT	3534-12GI	3534-12GB	26.15	3534-12GSP	3534-12GSF		
1/4	28	69.00	16.70	3534-1/4T	3534-1/4I	3534-1/4B	19.01	3534-1/4SP	3534-1/4SF		
5/16	24	76.00	19.64	3534-5/16T	3534-5/16I	3534-5/16B	22.58	3534-5/16SP	3534-5/16SF		
3/8	24	82.00	23.73	3534-3/8T	3534-3/8I	3534-3/8B	28.56	3534-3/8SP	3534-3/8SF		
7/16	20	84.00	26.99	3534-7/16T	3534-7/16I	3534-7/16B	32.45	3534-7/16SP	3534-7/16SF		
1/2	20	90.00	27.30	3534-1/2T	3534-1/2I	3534-1/2B	35.60	3534-1/2SP	3534-1/2SF		
9/16	18	104.00	44.52	3534-9/16T	3534-9/16I	3534-9/16B	59.33	3534-9/16SP	3534-9/16SF		
5/8	18	104.00	56.28	3534-5/8T	3534-5/8I	3534-5/8B	82.74	3534-5/8SP	3534-5/8SF		
3/4	16	104.00	70.98	3534-3/4T	3534-3/4I	3534-3/4B	83.90	3534-3/4SP	3534-3/4SF		
7/8	14	120.00	83.06	3534-7/8T	3534-7/8I	3534-7/8B	121.70	3534-7/8SP	3534-7/8SF		
1	12	127.00	91.46	3534-1T	3534-1I	3534-1B	142.38	3534-1SP	3534-1SF		
1	14	127.00	91.46	3535-1T	3535-1I	3535-1B	142.38	3535-1SP	3535-1SF		
1-1/8	12	137.00	168.53	3534-1.1/8T	3534-1.1/8I	3534-1.1/8B	–	–	–		
1-1/4	12	144.00	177.98	3534-1.1/4T	3534-1.1/4I	3534-1.1/4B	–	–	–		
1-3/8	12	150.00	219.56	3534-1.3/8T	3534-1.3/8I	3534-1.3/8B	–	–	–		
1-1/2	12	150.00	266.07	3534-1.1/2T	3534-1.1/2I	3534-1.1/2B	–	–	–		

GROUP	PCTP
MATERIAL	HSS
TOLERANCE	3B
TYPE	STI

BSW – STI TAPS						
INCH	TPI	MM	€	PART #	PART #	PART #
1/8	40	53.00	14.28	3528-1/8T	3528-1/8I	3528-1/8B
3/16	24	56.00	15.44	3528-3/16T	3528-3/16I	3528-3/16B
1/4	20	72.00	16.17	3528-1/4T	3528-1/4I	3528-1/4B
5/16	18	80.00	17.85	3528-5/16T	3528-5/16I	3528-5/16B
3/8	16	85.00	18.48	3528-3/8T	3528-3/8I	3528-3/8B
7/16	14	95.00	24.99	3528-7/16T	3528-7/16I	3528-7/16B
1/2	12	102.00	28.67	3528-1/2T	3528-1/2I	3528-1/2B
9/16	12	102.00	44.52	3528-9/16T	3528-9/16I	3528-9/16B
5/8	11	112.00	55.86	3528-5/8T	3528-5/8I	3528-5/8B
11/16	11	112.00	58.74	3528-11/16T	3528-11/16I	3528-11/16B
3/4	10	118.00	68.88	3528-3/4T	3528-3/4I	3528-3/4B
7/8	9	130.00	80.75	3528-7/8T	3528-7/8I	3528-7/8B
1	8	138.00	78.33	3528-1T	3528-1I	3528-1B

BSF – STI TAPS						
INCH	TPI	MM	€	PART #	PART #	PART #
3/16	32	66.00	15.44	3530-3/16T	3530-3/16I	3530-3/16B
1/4	26	72.00	16.17	3530-1/4T	3530-1/4I	3530-1/4B
5/16	22	80.00	17.85	3530-5/16T	3530-5/16I	3530-5/16B
3/8	20	85.00	18.48	3530-3/8T	3530-3/8I	3530-3/8B
7/16	18	89.00	24.99	3530-7/16T	3530-7/16I	3530-7/16B
1/2	16	95.00	28.67	3530-1/2T	3530-1/2I	3530-1/2B
9/16	16	102.00	44.52	3530-9/16T	3530-9/16I	3530-9/16B
5/8	14	112.00	55.86	3530-5/8T	3530-5/8I	3530-5/8B
11/16	14	112.00	68.36	3530-11/16T	3530-11/16I	3530-11/16B
3/4	12	118.00	68.88	3530-3/4T	3530-3/4I	3530-3/4B
7/8	11	130.00	80.75	3530-7/8T	3530-7/8I	3530-7/8B
1	10	138.00	78.33	3530-1T	3530-1I	3530-1B

BSP – STI TAPS						
INCH	TPI	MM	€	PART #	PART #	PART #
1/8	28	59.00	29.72	3546-1/8T	3546-1/8I	3546-1/8B
1/4	19	67.00	47.46	3546-1/4T	3546-1/4I	3546-1/4B
3/8	19	75.00	59.33	3546-3/8T	3546-3/8I	3546-3/8B
1/2	14	87.00	65.31	3546-1/2T	3546-1/2I	3546-1/2B
5/8	14	91.00	118.65	3546-5/8T	3546-5/8I	3546-5/8B
3/4	14	96.00	154.25	3546-3/4T	3546-3/4I	3546-3/4B
1	11	109.00	207.69	3546-1T	3546-1I	3546-1B



NPT, 8-UN,

BSC, BA



GROUP	PCTP
MATERIAL	HSS
TOLERANCE	3B
TYPE	STI

NPT – STI TAPS

INCH	TPI	MM	€	PART #	PART #	PART #
1/8	27	54.00	94.92	3552-1/8T	3552-1/8I	3552-1/8B
1/4	18	62.00	106.79	3552-1/4T	3552-1/4I	3552-1/4B
3/8	18	65.00	142.38	3552-3/8T	3552-3/8I	3552-3/8B
1/2	14	80.00	172.10	3552-1/2T	3552-1/2I	3552-1/2B
3/4	14	83.00	225.44	3552-3/4T	3552-3/4I	3552-3/4B
1	11.5	95.00	308.49	3552-1T	3552-1I	3552-1B

8-UN – STI TAPS

INCH	TPI	MM	€	PART #	PART #	PART #
1-1/8	8	151.00	338.31	3570-1.1/8T	3570-1.1/8I	3570-1.1/8B
1-1/4	8	162.00	389.66	3570-1.1/4T	3570-1.1/4I	3570-1.1/4B
1-3/8	8	170.00	442.26	3570-1.3/8T	3570-1.3/8I	3570-1.3/8B
1-1/2	8	170.00	485.84	3570-1.1/2T	3570-1.1/2I	3570-1.1/2B
1-5/8	8	187.00	568.26	3570-1.5/8T	3570-1.5/8I	3570-1.5/8B
1-3/4	8	187.00	615.51	3570-1.3/4T	3570-1.3/4I	3570-1.3/4B
1-7/8	8	200.00	715.47	3570-1.7/8T	3570-1.7/8I	3570-1.7/8B
2	8	200.00	610.79	3570-2T	3570-2I	3570-2B

BSC – STI TAPS

INCH	TPI	MM	€	PART #	PART #	PART #
1/4	26	69.00	17.85	3560-1/4T	3560-1/4I	3560-1/4B
5/16	26	76.00	23.73	3560-5/16T	3560-5/16I	3560-5/16B
3/8	26	82.00	29.72	3560-3/8T	3560-3/8I	3560-3/8B
7/16	26	84.00	41.58	3560-7/16T	3560-7/16I	3560-7/16B
1/2	26	90.00	35.60	3560-1/2T	3560-1/2I	3560-1/2B

BA – STI TAPS

INCH	INCH	MM	€	PART #	PART #	PART #
0	0.0394	66.00	16.38	3544-0T	3544-0I	3544-0B
2	0.0319	66.00	16.38	3544-2T	3544-2I	3544-2B
4	0.0260	53.00	16.38	3544-4T	3544-4I	3544-4B
6	0.0209	50.00	16.38	3544-6T	3544-6I	3544-6B



GROUP	PCIT
USAGE	GENERAL
INSERT TYPE	WIRE THREAD
INSERT STYLE	FREE RUNNING
APPLICATION	LOW VOLUME

HAND INSTALLATION TOOLS – HIT														
MC	MF	SPARK	UNC	UNF	BSW	BSF	BA	BSC	NPT	BSP	UN-8	€	PART #	
2X0.40	-	-	-	-	-	-	-	-	-	-	-	9.56	3500-HIT2	
2.20X0.45	-	-	2GX56	-	-	-	-	-	-	-	-	9.56	3500-HIT2	
2.50X0.45	-	-	3GX48	3GX56	-	-	#6	-	-	-	-	9.56	3500-HIT3	
3X0.50	-	-	4GX40	4GX48	1/8X40	-	-	-	-	-	-	9.56	3500-HIT4	
-	-	-	5GX40	-	-	-	-	-	-	-	-	9.56	3500-HIT4	
3.50X0.60	-	-	6GX32	6GX40	-	-	#4	-	-	-	-	9.56	3500-HIT5	
4X0.70	-	-	8GX32	8GX36	-	-	-	-	-	-	-	9.56	3500-HIT6	
5X0.80	-	-	12GX24	10GX32	-	3/16X32	#1	-	-	-	-	9.56	3500-HIT8	
6X1.00	-	-	1/4X20	1/4X28	1/4X20	1/4X26	#0	1/4X26	-	-	-	9.56	3500-HIT9	
7X1.00	-	-	5/16X18	-	5/16X18	-	-	-	1/16X27	-	-	10.92	3500-HIT10	
8X1.25	8X1.00	-	-	5/16X24	3/8X16	5/16X22	-	5/16X26	-	-	-	10.92	3500-HIT11	
9X1.25	10X1.25	10X1.00	3/8X16	3/8X24	-	3/8X20	-	3/8X26	-	-	-	11.55	3500-HIT13	
9X1.00	10X1.00	-	-	-	-	-	-	-	-	-	-	11.55	3500-HIT13	
10X1.50	-	-	-	-	-	-	-	-	1/8X27	-	-	11.55	3500-HIT13	
11X1.50	11X1.25	-	7/16X14	7/16X20	7/16X14	7/16X18	-	7/16X26	-	1/8X28	-	13.65	3500-HIT14	
-	11X1.00	-	-	-	-	-	-	-	-	-	-	13.65	3500-HIT14	
12X1.75	12X1.50	10X1.25	1/2X13	1/2X20	1/2X12	1/2X16	-	1/2X26	-	-	-	13.65	3500-HIT15	
12X1.00	12X1.25	-	-	-	-	-	-	-	-	-	-	13.65	3500-HIT15	
14X2.00	14X1.00	-	9/16X12	9/16X18	9/16X12	9/16X16	-	-	-	1/4X19	-	16.17	3500-HIT16	
15X2.00	14X1.50	-	-	-	-	-	-	-	1/4X18	-	-	16.17	3500-HIT16	
-	-	14X1.25	-	-	-	-	-	-	-	-	-	16.17	3500-HIT17	
16X2.00	16X1.50	-	5/8X11	5/8X18	5/8X11	5/8X14	-	-	3/8X18	-	-	17.64	3500-HIT18	
18X2.50	18X2.00	18X1.50	3/4X10	-	3/4X10	3/4X12	-	-	-	3/8X19	-	17.64	3500-HIT20	
-	18X1.50	-	-	-	-	-	-	-	-	-	-	17.64	3500-HIT20	
20X2.50	20X2.00	-	-	3/4X16	-	-	-	-	-	-	-	17.64	3500-HIT21	
-	20X1.50	-	-	-	-	-	-	-	-	-	-	17.64	3500-HIT21	
22X2.50	22X2.00	-	7/8X9	7/8X14	7/8X9	7/8X11	-	-	1/2X14	-	-	22.37	3500-HIT22	
-	22X1.50	-	-	-	-	-	-	-	-	-	-	22.37	3500-HIT22	
24X3.00	24X2.00	-	1X8	1X12	1X8	1X10	-	-	-	1/2X14	-	22.37	3500-HIT23	
-	24X1.50	-	-	1X14	-	-	-	-	-	5/8X14	-	22.37	3500-HIT23	
27X3.00	26X1.50	-	-	-	-	-	-	-	3/4X14	-	-	37.80	3500-HIT24	
30X3.00	-	-	1.1/8-7	1.1/8-12	-	-	-	-	-	-	1.1/8X8	37.80	3500-HIT25	
33X3.50	30X2.00	-	1.1/4-7	1.1/4-12	-	-	-	-	-	3/4X14	1.1/4X8	54.00	3500-HIT26	
-	-	-	1.3/8-6	1.3/8-12	-	-	-	-	1X11.5	7/8X14	1.3/8X8	58.44	3500-HIT27	
-	-	-	-	-	-	-	-	-	-	1X11	-	58.44	3500-HIT27	
36X4.00	36X2.00	-	1.1/2-6	1.1/2-12	-	-	-	-	-	-	1.1/2X8	62.51	3500-HIT28	
-	-	-	-	-	-	-	-	-	-	-	1.5/8X8	62.51	3500-HIT28	
-	-	-	-	-	-	-	-	-	-	-	1.3/4X8	62.51	3500-HIT28	
-	-	-	-	-	-	-	-	-	-	-	1.7/8X8	75.60	3500-HIT30	
-	-	-	-	-	-	-	-	-	-	-	2X8	75.60	3500-HIT30	



GROUP	PCIT
USAGE	GENERAL
INSERT TYPE	WIRE THREAD
INSERT STYLE	ALL
APPLICATION	LOW VOLUME



TANG BREAK TOOLS – TB : INSERT REMOVAL TOOLS – RT

MC	MF	SPARK	UNC	UNF	BSW	BSF	BA	BSC	€	PART #	€	PART #
2X0.40	-	-	-	-	-	-	-	-	3.99	3500-TB1	18.90	3500-RT1
2.20X0.45	-	-	2GX56	-	-	-	-	-	3.99	3500-TB2	18.90	3500-RT1
2.50X0.45	-	-	3GX48	3GX56	-	-	#6	-	3.99	3500-TB3	18.90	3500-RT1
-	-	-	4GX40	4GX48	1/8X40	-	-	-	3.99	3500-TB4	18.90	3500-RT1
3X0.50	-	-	-	4GX48	-	-	-	-	3.99	3500-TB4	19.74	3500-RT2
-	-	-	5GX40	-	-	-	-	-	3.99	3500-TB4	18.90	3500-RT1
3.50X0.60	-	-	-	-	-	-	-	-	3.99	3500-TB5	19.74	3500-RT2
-	-	-	6GX32	6GX40	-	-	#4	-	3.99	3500-TB5	18.90	3500-RT1
4X0.70	-	-	-	-	-	3/16X32	-	-	3.99	3500-TB6	19.74	3500-RT2
-	-	-	8GX32	8GX36	-	-	-	-	3.99	3500-TB6	18.90	3500-RT1
5X0.80	-	-	10GX24	10GX32	3/16X24	-	#2	-	3.99	3500-TB8	19.74	3500-RT2
-	-	-	12GX24	12GX28	-	-	-	-	3.99	3500-TB8	19.74	3500-RT2
6X1.00	-	-	1/4X20	1/4X28	1/4X20	1/4X26	-	1/4X26	3.99	3500-TB9	19.74	3500-RT2
7X1.00	-	-	-	-	5/16X18	5/16X22	#0	-	4.62	3500-TB11	19.74	3500-RT2
8X1.25	8X1.00	-	5/16X18	5/16X24	-	-	-	5/16X26	4.62	3500-TB12	19.74	3500-RT2
9X1.25	9X1.00	10X1.00	-	-	-	-	-	-	4.62	3500-TB12	19.74	3500-RT2
-	-	-	3/8X16	-	3/8X16	3/8X20	-	-	4.62	3500-TB12	24.05	3500-RT3
10X1.50	10X1.25	-	-	-	-	-	-	-	4.62	3500-TB13	19.74	3500-RT2
-	-	-	-	3/8X24	-	-	-	3/8X26	4.62	3500-TB13	24.05	3500-RT3
-	10X1.00	-	-	-	-	-	-	-	4.62	3500-TB13	19.74	3500-RT2
11X1.50	11X1.25	-	7/16X14	7/16X20	7/16X14	7/16X18	-	7/16X26	5.46	3500-TB14	24.05	3500-RT3
-	11X1.00	-	-	-	-	-	-	-	5.46	3500-TB14	24.05	3500-RT3
12X1.75	12X1.50	10X1.25	1/2X13	1/2X20	1/2X12	1/2X16	-	1/2X26	5.46	3500-TB15	24.05	3500-RT3
-	12X1.00	12X1.25	-	-	-	-	-	-	5.46	3500-TB15	24.05	3500-RT3
13X1.75	13X1.50	-	-	-	-	-	-	-	5.46	3500-TB15	24.05	3500-RT3
-	13X1.25	-	-	-	-	-	-	-	-	-	24.05	3500-RT3
14X2.00	14X1.50	14X1.25	9/16X12	9/16X18	9/16X12	9/16X16	-	-	-	-	24.05	3500-RT3
-	14X1.00	-	-	-	-	-	-	-	-	-	24.05	3500-RT3
15X2.00	15X1.50	-	-	-	-	-	-	-	-	-	24.05	3500-RT3
16X2.00	16X1.50	-	5/8X11	5/8X18	5/8X11	5/8X14	-	-	-	-	24.05	3500-RT3
18X2.50	18X2.00	18X1.50	3/4X10	-	3/4X10	3/4X12	-	-	-	-	24.05	3500-RT3
20X2.50	20X2.00	-	-	3/4X16	-	-	-	-	-	-	24.05	3500-RT3
-	20X1.50	-	-	-	-	-	-	-	-	-	24.05	3500-RT3
22X2.50	22X2.00	-	7/8X9	7/8X14	7/8X9	7/8X11	-	-	-	-	24.05	3500-RT3
-	22X1.50	-	-	-	-	-	-	-	-	-	24.05	3500-RT3
24X3.00	24X2.00	-	1X8	1X12	1X8	1X10	-	-	-	-	24.05	3500-RT3
-	24X1.50	-	-	1X14	-	-	-	-	-	-	24.05	3500-RT3
-	26X1.50	-	-	-	-	-	-	-	-	-	52.29	3500-RT4
27X3.00	27X2.00	-	-	-	-	-	-	-	-	-	52.29	3500-RT4
-	27X1.50	-	-	-	-	-	-	-	-	-	52.29	3500-RT4
-	28X1.50	-	-	-	-	-	-	-	-	-	52.29	3500-RT4
30X3.50	30X2.00	-	1.1/8X7	1.1/8X12	-	-	-	-	-	-	52.29	3500-RT4
-	30X1.50	-	1.1/4X7	1.1/4X12	-	-	-	-	-	-	52.29	3500-RT4
33X3.50	33X2.00	-	1.3/8X6	1.3/8X12	-	-	-	-	-	-	52.29	3500-RT4
36X4.00	36X3.00	-	1.1/2X6	1.1/2X12	-	-	-	-	-	-	52.29	3500-RT4
-	36X2.00	-	-	-	-	-	-	-	-	-	52.29	3500-RT4
-	36X1.50	-	-	-	-	-	-	-	-	-	52.29	3500-RT4



Note: For larger insert sizes, where a TB (Tang Break) tool is not listed, the tang break operation is performed using the HIT (Hand Installation Tool).

GROUP	PCIT
USAGE	GENERAL
INSERT TYPE	WIRE THREAD
INSERT STYLE	ALL
APPLICATION	MED. VOLUME



MACHINE INSTALLATION TOOLS – MIT : PREWINDER TOOLS – HIP : SPRING LOADED TANG BREAK TOOLS – STB								
MC	MF	SPARK	€	PART #	€	PART #	€	PART #
2X0.40	–	–	75.00	3520-2.00MIT	90.30	3520-2.00HIP	153.00	3500-STB1
2.20X0.45	–	–	75.00	3520-2.20MIT	90.30	3520-2.20HIP	153.00	3500-STB1
2.50X0.45	–	–	75.00	3520-2.50MIT	90.30	3520-2.50HIP	153.00	3500-STB2
3X0.50	–	–	69.00	3520-3.00MIT	73.50	3520-3.00HIP	153.00	3500-STB4
3.50X0.60	–	–	69.00	3520-3.50MIT	73.50	3520-3.50HIP	153.00	3500-STB4
4X0.70	–	–	69.00	3520-4.00MIT	73.50	3520-4.00HIP	153.00	3500-STB5
5X0.80	–	–	69.00	3520-5.00MIT	73.50	3520-5.00HIP	153.00	3500-STB6
6X1.00	–	–	69.00	3520-6.00MIT	73.50	3520-6.00HIP	153.00	3500-STB8
7X1.00	–	–	69.00	3520-7.00MIT	73.50	3520-7.00HIP	–	–
8X1.25	–	–	69.00	3520-8.00MIT	73.50	3520-8.00HIP	218.70	3500-STB9
–	8X1.00	–	69.00	3521-8.00MIT	76.65	3521-8.00HIP	218.70	3500-STB9
10X1.50	–	–	75.00	3520-10.00MIT	90.30	3520-10.00HIP	218.70	3500-STB10
–	10X1.25	–	75.00	3521-10.00MIT	81.90	3521-10.00HIP	218.70	3500-STB10
–	10X1.00	–	75.00	3523-10.00MIT	90.30	3523-10.00HIP	218.70	3500-STB10
11X1.50	–	–	80.00	3520-11.00MIT	90.30	3520-11.00HIP	–	–
12X1.75	–	–	80.00	3520-12.00MIT	90.30	3520-12.00HIP	261.90	3500-STB12
–	12X1.50	–	80.00	3521-12.00MIT	81.90	3521-12.00HIP	261.90	3500-STB12
–	–	12X1.25	80.00	3523-12.00MIT	90.30	3523-12.00HIP	261.90	3500-STB12
–	12X1.00	–	–	–	–	–	261.90	3500-STB12
14X2.00	–	–	85.00	3520-14.00MIT	90.30	3520-14.00HIP	–	–
–	14X1.50	–	85.00	3521-14.00MIT	90.30	3521-14.00HIP	–	–
–	–	14X1.25	85.00	3523-14.00MIT	179.55	3523-14.00HIP	–	–
16X2.00	–	–	85.00	3520-16.00MIT	90.30	3520-16.00HIP	–	–
–	16X1.50	–	85.00	3521-16.00MIT	98.70	3521-16.00HIP	–	–

PowerCoil Installation and Extraction Tools

HIT Hand Installation Tool

The most flexible and cost effective installation tool for small volume applications – free running inserts only.

TB Tang Break Tool

Used to break the tang off inserts up to M13 or 1/2". Over these sizes and up to M24 or 1" the HIT tool is used to both install and break the tang.

RT Removal Tool

A quick and simple way to remove inserts up to M36 or 1.1/2" in diameter.

MIT Machine Installation Tool

1/4" hex shank tool suitable for use with electric and cordless tools. Ideal for medium volume installation using bulk free running and screw locking inserts.

HIP Hand Installation Prewinder Tool

For simplified installation of bulk free running and screw locking inserts in low to medium volume applications. HIP tools are ideal for installing MIL spec inserts.

STB Spring Loaded Tang Break Tool

Spring loaded tang break tools increase the efficiency of the tang break procedure in medium to high volume applications.



MIP Machine Installation – Pneumatic

The use of Front End Assemblies with Pneumatic Tools provides maximum efficiency in high volume applications when using strip feed free running and screw locking inserts.

GROUP	PCIT
USAGE	GENERAL
INSERT TYPE	WIRE THREAD
INSERT STYLE	ALL
APPLICATION	MED. VOLUME



MACHINE INSTALLATION TOOLS – MIT : PREWINDER TOOLS – HIP : SPRING LOADED TANG BREAK TOOLS – STB

							
UNC	UNF	€	PART #	€	PART #	€	PART #
2GX56	-	75.00	3532-2GMIT	81.90	3532-2GHIP	153.00	3500-STB1
3GX48	-	-	-	81.90	3532-3GHIP	-	-
-	3GX56	-	-	74.22	3534-3GHIP	-	-
4GX40	-	75.00	3532-4GMIT	66.15	3532-4GHIP	153.00	3500-STB3
-	4GX48	75.00	3534-4GMIT	66.15	3534-4GHIP	153.00	3500-STB3
5GX40	-	75.00	3532-5GMIT	66.15	3532-5GHIP	153.00	3500-STB3
6GX32	-	69.00	3532-6GMIT	66.15	3532-6GHIP	153.00	3500-STB4
-	6GX40	69.00	3534-6GMIT	66.15	3534-6GHIP	153.00	3500-STB4
8GX32	-	69.00	3532-8GMIT	66.15	3532-8GHIP	153.00	3500-STB5
-	8GX36	69.00	3534-8GMIT	66.15	3534-8GHIP	153.00	3500-STB5
10GX24	-	69.00	3532-10GMIT	66.15	3532-10GHIP	153.00	3500-STB6
-	10GX32	69.00	3534-10GMIT	66.15	3534-10GHIP	153.00	3500-STB6
12GX24	-	69.00	3532-12GMIT	66.15	3532-12GHIP	153.00	3500-STB7
-	12GX28	-	-	74.22	3534-12GHIP	153.00	3500-STB7
1/4X20	-	69.00	3532-1/4MIT	66.15	3532-1/4HIP	153.00	3500-STB8
-	1/4X28	69.00	3534-1/4MIT	66.15	3534-1/4HIP	153.00	3500-STB8
5/16X18	-	69.00	3532-5/16MIT	73.50	3532-5/16HIP	218.70	3500-STB9
-	5/16X24	69.00	3534-5/16MIT	73.50	3534-5/16HIP	218.70	3500-STB9
3/8X16	-	75.00	3532-3/8MIT	81.90	3532-3/8HIP	218.70	3500-STB10
-	3/8X24	75.00	3534-3/8MIT	81.90	3534-3/8HIP	218.70	3500-STB10
7/16X14	-	75.00	3532-7/16MIT	81.90	3532-7/16HIP	261.90	3500-STB11
-	7/16X20	75.00	3534-7/16MIT	81.90	3534-7/16HIP	261.90	3500-STB11
1/2X13	-	80.00	3532-1/2MIT	81.90	3532-1/2HIP	261.90	3500-STB12
-	1/2X20	80.00	3534-1/2MIT	81.90	3534-1/2HIP	261.90	3500-STB12

GROUP	PCIT
USAGE	GENERAL
INSERT TYPE	WIRE THREAD
INSERT STYLE	ALL
APPLICATION	HIGH VOLUME



PNEUMATIC TOOLS AND FRONT END ASSEMBLIES

MC	MF	€	PART #	€	PART #	€	PART #	€	PART #
2X0.40	-	400.00	3520-2.20MIP	146.00	3520-2.20MIPM	255.00	3520-2.20MIPN	1500.00	3500-MIP1
2.50X0.45	-	255.00	3520-2.50MIP	92.00	3520-2.50MIPM	164.00	3520-2.50MIPN	1500.00	3500-MIP1
3X0.50	-	255.00	3520-3.00MIP	92.00	3520-3.00MIPM	164.00	3520-3.00MIPN	1500.00	3500-MIP1
3.50X0.60	-	400.00	3520-3.50MIP	146.00	3520-3.50MIPM	255.00	3520-3.50MIPN	1500.00	3500-MIP1
4X0.70	-	255.00	3520-4.00MIP	92.00	3520-4.00MIPM	164.00	3520-4.00MIPN	1500.00	3500-MIP1
5X0.80	-	255.00	3520-5.00MIP	92.00	3520-5.00MIPM	164.00	3520-5.00MIPN	1500.00	3500-MIP1
6X1.00	-	255.00	3520-6.00MIP	92.00	3520-6.00MIPM	164.00	3520-6.00MIPN	1500.00	3500-MIP1
8X1.25	-	545.00	3520-8.00MIP	200.00	3520-8.00MIPM	346.00	3520-8.00MIPN	1770.00	3500-MIP2
-	8X1.00	545.00	3521-8.00MIP	200.00	3521-8.00MIPM	346.00	3521-8.00MIPN	1770.00	3500-MIP2
10X1.50	-	545.00	3520-10.00MIP	200.00	3520-10.00MIPM	346.00	3520-10.00MIPN	1770.00	3500-MIP2
-	10X1.25	545.00	3521-10.00MIP	200.00	3521-10.00MIPM	346.00	3521-10.00MIPN	1770.00	3500-MIP2
-	10X1.00	364.00	3523-10.00MIP	128.00	3523-10.00MIPM	237.00	3523-10.00MIPN	1770.00	3500-MIP2
12X1.75	-	364.00	3520-12.00MIP	128.00	3520-12.00MIPM	237.00	3520-12.00MIPN	1770.00	3500-MIP2
-	12X1.50	618.00	3521-12.00MIP	237.00	3521-12.00MIPM	382.00	3521-12.00MIPN	1770.00	3500-MIP2
-	12X1.25	618.00	3523-12.00MIP	237.00	3523-12.00MIPM	382.00	3523-12.00MIPN	1770.00	3500-MIP2

PNEUMATIC TOOLS AND FRONT END ASSEMBLIES

UNC	UNF	€	PART #	€	PART #	€	PART #	€	PART #
2GX56	-	376.00	3532-2GMIP	146.00	3532-2GMIPM	231.00	3532-2GMIPN	1500.00	3500-MIP1
4GX40	-	255.00	3532-4GMIP	92.00	3532-4GMIPM	164.00	3532-4GMIPN	1500.00	3500-MIP1
5GX40	-	400.00	3532-5GMIP	146.00	3532-5GMIPM	255.00	3532-5GMIPN	1500.00	3500-MIP1
6GX32	-	255.00	3532-6GMIP	92.00	3532-6GMIPM	164.00	3532-6GMIPN	1500.00	3500-MIP1
-	6GX40	400.00	3534-6GMIP	146.00	3534-6GMIPM	255.00	3534-6GMIPN	1500.00	3500-MIP1
8GX32	-	255.00	3532-8GMIP	92.00	3532-8GMIPM	164.00	3532-8GMIPN	1500.00	3500-MIP1
-	8GX36	400.00	3534-8GMIP	146.00	3534-8GMIPM	255.00	3534-8GMIPN	1500.00	3500-MIP1
10GX24	-	255.00	3532-10GMIP	92.00	3532-10GMIPM	164.00	3532-10GMIPN	1500.00	3500-MIP1
-	10GX32	255.00	3534-10GMIP	92.00	3534-10GMIPM	164.00	3534-10GMIPN	1500.00	3500-MIP1
12GX24	-	255.00	3532-12GMIP	92.00	3532-12GMIPM	164.00	3532-12GMIPN	1500.00	3500-MIP1
1/4X20	-	255.00	3532-1/4MIP	92.00	3532-1/4MIPM	164.00	3532-1/4MIPN	1500.00	3500-MIP1
-	1/4X28	255.00	3534-1/4MIP	92.00	3534-1/4MIPM	164.00	3534-1/4MIPN	1500.00	3500-MIP1
5/16X18	-	545.00	3532-5/16MIP	200.00	3532-5/16MIPM	346.00	3532-5/16MIPN	1770.00	3500-MIP2
-	5/16X24	545.00	3534-5/16MIP	200.00	3534-5/16MIPM	346.00	3534-5/16MIPN	1770.00	3500-MIP2
3/8X16	-	545.00	3532-3/8MIP	200.00	3532-3/8MIPM	346.00	3532-3/8MIPN	1770.00	3500-MIP2
-	3/8X24	545.00	3534-3/8MIP	200.00	3534-3/8MIPM	346.00	3534-3/8MIPN	1770.00	3500-MIP2
7/16X14	-	618.00	3532-7/16MIP	237.00	3532-7/16MIPM	382.00	3532-7/16MIPN	1770.00	3500-MIP2
-	7/16X20	618.00	3534-7/16MIP	237.00	3534-7/16MIPM	382.00	3534-7/16MIPN	1770.00	3500-MIP2
1/2X13	-	618.00	3532-1/2MIP	237.00	3532-1/2MIPM	382.00	3532-1/2MIPN	1770.00	3500-MIP2
-	1/2X20	618.00	3534-1/2MIP	237.00	3534-1/2MIPM	382.00	3534-1/2MIPN	1770.00	3500-MIP2



Front End Assemblies (MIP) include the Mandrel (MIPM), Nozzle (MIPN), spacers to suit 1.0D, 1.5D and 2.0D inserts plus a set of shim washers for fine adjustment of installation depth.

Pneumatic Wire Thread Installation Tools and Front End Assemblies Overview

Detailed instructions are included with every Pneumatic Tool and Front End Assembly.

You will need

- A front-end assembly appropriate to the Wire Thread Inserts you wish to install and the applicable pneumatic tool.
- An air supply providing air pressure up to 100psi (7 bar) incorporating a filtered and lubricated air regulator. Your air supply should also incorporate an isolating switch to stop the air supply to the tool and connectors/couplings.
- PTFE tape should be wound around the threaded end of the air connector prior to screwing into air tool to ensure a good seal.
- If tool is to be used with a work arm assembly please ensure that the instructions supplied with that equipment are read in conjunction with these instructions.

Front-end assembly

The front-end assembly is used in conjunction with the pneumatic installation tool to aid the installation of Wire Thread Inserts. The front-end assembly winds a mandrel through the insert (1.0D, 1.5D or 2.0D) and through the pre-winder nozzle. When the insert emerges from the nozzle the diameter has been reduced (pre-wound) to facilitate easy entry into the prepared and threaded hole in the parent material.

The front-end assembly consists of two main components • Nozzle • Mandrel

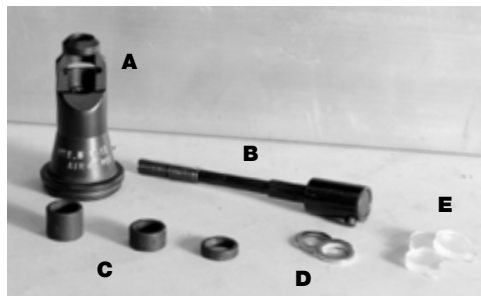

- A Nozzle
- B Mandrel
- C Thickness spacers
- D Shim washers
- E Cushions (for use in the adaptor of an ARO® brand pneumatic tool only)

Three different mandrel types are used depending on the size of the inserts being installed.

Check that the front-end assembly pack also contains 2 or 3 thickness spacers (to suit different length inserts) and at least 3 shim washers. Wire Thread Inserts should be installed 3/4 to 1-1/2 pitches below the surface of a countersunk hole or 1/4 to 1/2 coil below the surface of a flush hole. The Wire Thread Insert must be fully engaged with the thread in the hole throughout its length.

Separate mandrel from nozzle by rotating the mandrel anti-clockwise until the mandrel disengages. You can now assemble the correct combination of spacers and shims (if necessary) between the clutch seat and nozzle.

Identify the length of the insert to be installed and select spacers to adjust insertion depth eg: for 1.0D inserts select the longest spacer - the longer the insert the shorter the required spacer. Once the spacers and shims have been positioned on the shaft of the mandrel lubricate the mandrel thread with light machine oil and wind the mandrel through the nozzle. Locate the mandrel pin in the slot of the driving spline (inside the adaptor case) and slide the front end assembly into the case. Tighten the retaining ring (anti-clockwise) finger tight only - over tightening will restrict free movement of the mandrel, possibly resulting in damage. **The mandrel should always be wound through the nozzle so that the threaded section is fully disengaged prior to assembling the tool.**



Front end assembly with longest spacer to suit 1.0D insert.



Front end assembly with longest spacer to suit 1.0D insert and shim washer.



Finished front end assembly with mandrel wound through the pre-winder nozzle.



Locate mandrel pin in the slot of the driving spline and slide the front end assembly into the case.

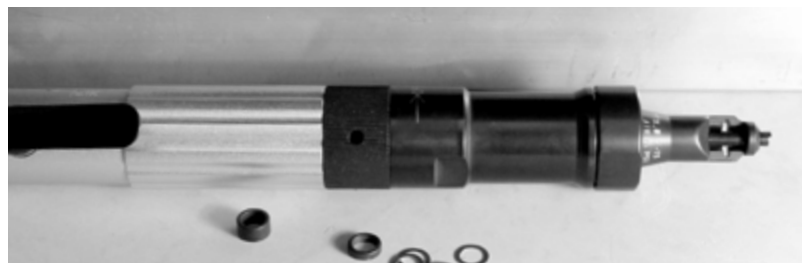

Ensure the front end assembly insert chamber opening is aligned with the trigger of the air motor. Final adjustments may still need to be made (using shim washers) to ensure that the inserts are installed to the optimum depth.

Recommended air pressures

Insert size – inch	#2	#3	#6	#8	#10	1/4"	5/16"	3/8"	7/16"	1/2"
Insert size – metric	M2.0-2.2	M2.5	M3.0	M3.5	M4.0-4.5	M6.0-7.0	M8.0	M10.0	M11.0	M12.0
Recommended pressure – psi	25	25-30	25-30	40	45	50-60	60	70	70-80	90
Recommended pressure – bar	1.7	1.7-2.0	1.7-2.0	2.8	3.0	3.5-4.1	4.1	4.8	4.8-5.5	6.2

Detailed usage manuals, instructions and exploded diagrams are available for download at powercoil.com.au

loksert[®]

SOLID
KEYLOCKING

 **BORDO**[®]
INDUSTRIAL TOOLS





GROUP	PSCI	PSSI
INSERT TYPE	SOLID KEYLOCKING	SOLID KEYLOCKING
INSERT MATERIAL	CARBON STEEL	STAINLESS STEEL
STYLE	THIN WALL	THIN WALL

METRIC COARSE

MM	MM	MM X MM	MM	€	PART #	€	PART #	#	MM	PART #	PART #	MM
5.00	0.80	8.00 X 1.25	8.00	71.12	3620-5.00TWK	117.37	3720-5.00TWK	5	6.9	3620-8.00I	3600-190T	8.25*
6.00	1.00	10.00 X 1.25	10.00	85.92	3620-6.00TWK	129.92	3720-6.00TWK	5	8.8	3621-10.00I	3600-250T	10.25*
8.00	1.25	12.00 X 1.25	12.00	106.92	3620-8.00TWK	151.17	3720-8.00TWK	5	10.8	3622-12.00I	3600-312T	12.25*
10.00	1.50	14.00 X 1.50	14.00	133.02	3620-10.00TWK	176.52	3720-10.00TWK	5	12.8	3621-14.00I	3600-375T	14.25*
12.00	1.75	16.00 X 1.50	16.00	153.99	3620-12.00TWK	200.24	3720-12.00TWK	5	14.75	3621-16.00I	3600-500T	16.25*

METRIC FINE

MM	MM	MM X MM	MM	€	PART #	€	PART #	#	MM	PART #	PART #	MM
8.00	1.00	12.00 X 1.25	12.00	86.42	3621-8.00TWK	151.17	3721-8.00TWK	5	10.8	3622-12.00I	3600-312T	12.25*
10.00	1.25	14.00 X 1.50	14.00	133.02	3621-10.00TWK	176.52	3721-10.00TWK	5	12.8	3621-14.00I	3600-375T	14.25*
12.00	1.25	16.00 X 1.50	16.00	153.99	3621-12.00TWK	200.24	3721-12.00TWK	5	14.75	3621-16.00I	3600-500T	16.25*

UNC

INCH	TPI	INCH X TPI	INCH	€	PART #	€	PART #	#	INCH	PART #	PART #	INCH
10G	24	5/16 X 18	0.31	56.83	3632-10GTWK	71.83	3732-10GTWK	5	I	3632-5/16I	3600-190T	0.32*
1/4	20	3/8 X 16	0.37	60.93	3632-1/4TWK	75.43	3732-1/4TWK	5	Q	3632-3/8I	3600-250T	0.38*
5/16	18	7/16 X 14	0.43	74.00	3632-5/16TWK	112.50	3732-5/16TWK	5	X	3632-7/16I	3600-312T	0.44*
3/8	16	1/2 X 13	0.50	82.24	3632-3/8TWK	132.24	3732-3/8TWK	5	29/64	3632-1/2I	3600-375T	0.51*
7/16	14	9/16 X 12	0.56	110.84	3632-7/16TWK	189.34	3732-7/16TWK	5	33/64	3632-9/16I	3600-375T	0.57*
1/2	13	5/8 X 11	0.62	128.22	3632-1/2TWK	206.72	3732-1/2TWK	5	37/64	3632-5/8I	3600-500T	0.63*

UNF

INCH	TPI	INCH X TPI	INCH	€	PART #	€	PART #	#	INCH	PART #	PART #	INCH
10G	32	5/16 X 18	0.31	56.83	3634-10GTWK	71.83	3734-10GTWK	5	I	3632-5/16I	3600-190T	0.32*
1/4	28	3/8 X 16	0.37	60.93	3634-1/4TWK	75.43	3734-1/4TWK	5	Q	3632-3/8I	3600-250T	0.38*
5/16	24	7/16 X 14	0.43	74.00	3634-5/16TWK	112.50	3734-5/16TWK	5	X	3632-7/16I	3600-312T	0.44*
3/8	24	1/2 X 13	0.50	82.24	3634-3/8TWK	132.24	3734-3/8TWK	5	29/64	3632-1/2I	3600-375T	0.51*
7/16	20	9/16 X 12	0.56	110.84	3634-7/16TWK	189.34	3734-7/16TWK	5	33/64	3632-9/16I	3600-375T	0.57*
1/2	20	5/8 X 11	0.62	128.22	3634-1/2TWK	206.72	3734-1/2TWK	5	37/64	3632-5/8I	3600-500T	0.63*

* Countersink not included in kit.

Loksert Features and Benefits

Solid bushing utilising locking keys provides positive mechanical lock against rotation.

High strength and reliability provides maximum pullout strength.

Installed using standard drills and taps.

Simple installation - no special skills required.

Suitable for use in a wide range of parent materials.

Impossible to cross thread during installation.

Simple removal process if required.

No tang to break and remove.

Available in metric sizes and inch sizes.

Available in Thinwall and Heavy Duty.

GROUP	PSCI	PSSI
INSERT TYPE	SOLID KEYLOCKING	SOLID KEYLOCKING
INSERT MATERIAL	CARBON STEEL	STAINLESS STEEL
STYLE	HEAVY DUTY	HEAVY DUTY

METRIC COARSE												
MM	MM	MM X MM	MM	€	PART #	€	PART #	#	MM	PART #	PART #	MM
5.00	0.80	10.00 X 1.25	10.00	85.22	3620-5.00HDK	131.47	3720-5.00HDK	5	8.80	3621-10.00I	3600-190T	5.25*
6.00	1.00	12.00 X 1.25	12.00	98.52	3620-6.00HDK	142.52	3720-6.00HDK	5	10.80	3622-12.00I	3600-250T	12.25*
8.00	1.25	14.00 X 1.50	14.00	122.52	3620-8.00HDK	166.77	3720-8.00HDK	5	12.80	3621-14.00I	3600-312T	14.25*
10.00	1.50	16.00 X 1.50	16.00	136.74	3620-10.00HDK	180.24	3720-10.00HDK	5	14.75	3621-16.00I	3600-375T	16.25*
12.00	1.75	18.00 X 1.50	18.00	206.55	3620-12.00HDK	252.80	3720-12.00HDK	5	16.75	3622-18.00I	3600-500T	18.25*
16.00	2.00	22.00 X 1.50	22.00	281.13	3620-16.00HDK	343.63	3720-16.00HDK	5	20.50	3621-22.00I	3600-625T	20.25*

METRIC FINE												
MM	MM	MM X MM	MM	€	PART #	€	PART #	#	MM	PART #	PART #	MM
8.00	1.00	14.00 X 1.50	14.00	125.05	3621-8.00HDK	169.30	3721-8.00HDK	5	12.80	3621-14.00I	3600-312T	14.25*
10.00	1.25	16.00 X 1.50	16.00	136.74	3621-10.00HDK	180.24	3721-10.00HDK	5	14.75	3621-16.00I	3600-375T	16.25*
12.00	1.25	18.00 X 1.50	18.00	206.55	3621-12.00HDK	252.80	3721-12.00HDK	5	16.75	3622-18.00I	3600-500T	18.25*
16.00	1.50	22.00 X 1.50	22.00	281.13	3621-16.00HDK	343.63	3721-16.00HDK	5	20.50	3621-22.00I	3600-625T	20.25*

UNC												
INCH	TPI	INCH X TPI	INCH	€	PART #	€	PART #	#	INCH	PART #	PART #	INCH
10G	24	3/8 X 16	0.31	61.23	3632-10GHDK	76.23	3732-10GHDK	5	Q	3632-3/8I	3600-190T	0.32*
1/4	20	7/16 X 14	0.37	68.60	3632-1/4HDK	83.10	3732-1/4HDK	5	X	3632-7/16I	3600-250T	0.38*
5/16	18	1/2 X 13	0.43	79.24	3632-5/16HDK	117.74	3732-5/16HDK	5	29/64	3632-1/2I	3600-312T	0.44*
3/8	16	9/16 X 12	0.50	101.84	3632-3/8HDK	151.84	3732-3/8HDK	5	33/64	3632-9/16I	3600-375T	0.51*
7/16	14	5/8 X 11	0.56	118.97	3632-7/16HDK	197.47	3732-7/16HDK	5	37/64	3632-5/8I	3600-375T	0.57*
1/2	13	3/4 X 16	0.62	165.57	3632-1/2HDK	244.07	3732-1/2HDK	5	45/64	3632-3/4I	3600-500T	0.63*
9/16	12	3/4 X 16	0.81	182.07	3632-9/16HDK	262.07	3732-9/16HDK	5	45/64	3632-3/4I	3600-500T	0.82*
5/8	11	7/8 X 14	0.87	223.82	3632-5/8HDK	330.32	3732-5/8HDK	5	53/64	3632-7/8I	3600-625T	0.88*

UNF												
INCH	TPI	INCH X TPI	INCH	€	PART #	€	PART #	#	INCH	PART #	PART #	INCH
10G	32	3/8 X 16	0.31	61.23	3634-10GHDK	76.23	3734-10GHDK	5	Q	3632-3/8I	3600-190T	0.32*
1/4	28	7/16 X 14	0.37	68.60	3634-1/4HDK	83.10	3734-1/4HDK	5	X	3632-7/16I	3600-250T	0.38*
5/16	24	1/2 X 13	0.43	79.24	3634-5/16HDK	117.74	3734-5/16HDK	5	29/64	3632-1/2I	3600-312T	0.44*
3/8	24	9/16 X 12	0.50	101.84	3634-3/8HDK	151.84	3734-3/8HDK	5	33/64	3632-9/16I	3600-375T	0.51*
7/16	20	5/8 X 11	0.56	118.97	3634-7/16HDK	197.47	3734-7/16HDK	5	37/64	3632-5/8I	3600-375T	0.57*
1/2	20	3/4 X 16	0.62	165.57	3634-1/2HDK	244.07	3734-1/2HDK	5	45/64	3632-3/4I	3600-500T	0.63*
19/16	18	3/4 X 16	0.81	182.07	3634-9/16HDK	262.07	3734-9/16HDK	5	45/64	3632-3/4I	3600-500T	0.82*
5/8	18	7/8 X 14	0.87	223.82	3634-5/8HDK	330.32	3734-5/8HDK	5	53/64	3632-7/8I	3600-625T	0.88*

* Countersink not included in kit.



Loksert

Loksert solid keylocking inserts are an easily installed thread assembly that is ideal for replacing damaged or worn threads in virtually any material – ferrous, non-ferrous and non-metallic.

They are constructed from high quality carbon steel or extremely hard wearing stainless steel. One piece Loksert inserts are supplied with the dove-tailed locking keys pre-assembled. The pre-positioned keys automatically position the insert at the correct depth below the surface of the parent material. Lokserts are suitable for repairing and creating threads in a wide range of applications including forgings and castings and are especially suited to situations that experience heavy wear and vibration - such as mining, construction and earthmoving equipment.

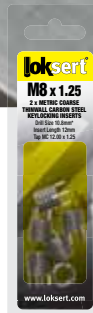

GROUP	PSCI
INSERT TYPE	SOLID KEYLOCKING
INSERT MATERIAL	CARBON STEEL
STYLE	THIN WALL

METRIC COARSE						
MM	MM	MM X MM	MM	#	€	PART #
5.00	0.80	8.00 X 1.25	8.00	5	37.50	3620-5.00TWP
6.00	1.00	10.00 X 1.25	10.00	5	40.00	3620-6.00TWP
8.00	1.25	12.00 X 1.25	12.00	5	44.50	3620-8.00TWP
10.00	1.50	14.00 X 1.50	14.00	5	55.00	3620-10.00TWP
12.00	1.75	16.00 X 1.50	16.00	5	70.00	3620-12.00TWP

METRIC FINE						
MM	MM	MM X MM	MM	#	€	PART #
8.00	1.00	12.00 X 1.25	12.00	5	44.50	3621-8.00TWP
10.00	1.25	14.00 X 1.50	14.00	5	55.00	3621-10.00TWP
12.00	1.25	16.00 X 1.50	16.00	5	70.00	3621-12.00TWP

UNC						
INCH	TPI	INCH X TPI	INCH	#	€	PART #
10G	24	5/16 X 18	0.31	5	24.00	3632-10GTWP
1/4	20	3/8 X 16	0.37	5	25.50	3632-1/4TWP
5/16	18	7/16 X 14	0.43	5	27.00	3632-5/16TWP
3/8	16	1/2 X 13	0.50	5	30.00	3632-3/8TWP
7/16	14	9/16 X 12	0.56	5	39.00	3632-7/16TWP
1/2	13	5/8 X 11	0.62	5	46.00	3632-1/2TWP

UNF						
INCH	TPI	INCH X TPI	INCH	#	€	PART #
10G	32	5/16 X 18	0.31	5	24.00	3634-10GTWP
1/4	28	3/8 X 16	0.37	5	25.50	3634-1/4TWP
5/16	24	7/16 X 14	0.43	5	27.00	3634-5/16TWP
3/8	24	1/2 X 13	0.50	5	30.00	3634-3/8TWP
7/16	20	9/16 X 12	0.56	5	39.00	3634-7/16TWP
1/2	20	5/8 X 11	0.62	5	46.00	3634-1/2TWP

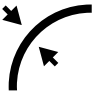

GROUP	PSCI
INSERT TYPE	SOLID KEYLOCKING
INSERT MATERIAL	CARBON STEEL
STYLE	THIN WALL

Loksert Features and Benefits

Solid bushing utilising locking keys provides positive mechanical lock against rotation.

High strength and reliability provides maximum pullout strength.

Installed using standard drills and taps.

Simple installation - no special skills required.

Suitable for use in a wide range of parent materials.

Impossible to cross thread during installation.

Simple removal process if required.

No tang to break and remove.

Available in metric sizes and inch sizes.

Available in Thinwall and Heavy Duty.

MERCHANDISER					
	€	PART #	#		
LOKSERT HANG SELL MERCHANDISER	749.78	3600-D1			
			2	M6.00 x 1.00	3620-6.00TWP
			2	M8.00 x 1.25	3620-8.00TWP
			1	M10.00 x 1.50	3620-10.00TWP
			1	M12.00 x 1.75	3620-12.00TWP
			1	UNC 1/4 x 20	3632-1/4TWP
			1	UNC 5/16 x 18	3632-5/16TWP
			1	UNC 3/8 x 16	3632-3/8TWP
			1	UNC 1/2 x 13	3632-1/2TWP
			1	UNF1/4 x 28	3634-1/4TWP
			1	UNF 3/8 x 24	3634-3/8TWP
			1	HSS DRILL 8.8mm	3620-8.8
			1	HSS DRILL 10.8mm	3620-10.8
			1	HSS DRILL 12.8mm	3620-12.8
			1	HSS DRILL 14.75mm	3620-14.75
			1	HSS DRILL Q(8.43/0.332)	3632-Q
			1	HSS DRILL X(10.0/0.397)	3632-X
			1	HSS DRILL 29/64	3632-29/64
			1	HSS DRILL 37/64	3632-37/64
			1	TAP INTER 10.00 x 1.25	3621-10.00I
			1	TAP INTER 12.00 x 1.25	3622-12.00I
			1	TAP INTER 14.00 x 1.5	3621-14.00I
			1	TAP INTER 16.00 x 1.5	3621-16.00I
			1	TAP INTER 3/8 x 16	3632-3/8I
			1	TAP INTER 7/16 x 14	3632-7/16I
			1	TAP INTER 1/2 x 13	3632-1/2I
			1	TAP INTER 5/8 x 11	3632-5/8I
			1	UNIVERSAL TOOL	3600-250T
			1	UNIVERSAL TOOL	3600-312T
			1	UNIVERSAL TOOL	3600-375T
			1	UNIVERSAL TOOL	3600-500T



GROUP	PSCI
INSERT TYPE	SOLID KEYLOCKING
INSERT MATERIAL	CARBON STEEL
STYLE	THIN WALL



METRIC COARSE – THIN WALL CARBON STEEL BULK INSERTS												
						€ EACH	€ EACH	€ EACH	€ EACH	€ EACH	€ EACH	€ EACH
MM	MM	MM	MM	MM	PART #	1	2	3	4	6	100	500
5.00	0.80	10.00 X 1.25	8.00	6.9	3620-5.00TW	-	-	-	7.50	4.60	4.20	3.80
6.00	1.00	12.00 X 1.25	10.00	8.8	3620-6.00TW	-	-	-	8.00	4.90	4.60	4.10
8.00	1.25	14.00 X 1.50	12.00	10.8	3620-8.00TW	-	-	-	8.90	5.50	5.10	4.60
10.00	1.50	16.00 X 1.50	14.00	12.8	3620-10.00TW	-	-	-	11.00	6.80	6.20	5.60
12.00	1.75	18.00 X 1.50	16.00	14.75	3620-12.00TW	-	-	-	14.00	8.50	7.90	7.10

METRIC FINE – THIN WALL CARBON STEEL BULK INSERTS												
						€ EACH	€ EACH	€ EACH	€ EACH	€ EACH	€ EACH	€ EACH
MM	MM	MM	MM	MM	PART #	1	2	3	4	6	100	500
8.00	1.00	14.00 X 1.50	12.00	10.8	3621-8.00TW	-	-	-	8.90	5.50	5.10	4.60
10.00	1.25	16.00 X 1.50	14.00	12.8	3621-10.00TW	-	-	-	11.00	6.80	6.20	5.60
12.00	1.25	18.00 X 1.50	16.00	14.75	3621-12.00TW	-	-	-	14.00	8.50	7.90	7.10

UNC – THIN WALL CARBON STEEL BULK INSERTS												
						€ EACH	€ EACH	€ EACH	€ EACH	€ EACH	€ EACH	€ EACH
INCH	TPI	INCH X TPI	INCH	INCH	PART #	1	2	3	4	6	100	500
10G	24	5/16 X 18	0.31	I	3632-10GTW	-	-	-	4.80	2.90	2.70	2.50
1/4	20	3/8 X 16	0.37	Q	3632-1/4TW	-	-	-	5.10	3.10	2.80	2.70
5/16	18	7/16 X 14	0.43	X	3632-5/16TW	-	-	-	5.40	3.30	3.00	2.80
3/8	16	1/2 X 13	0.50	29/64	3632-3/8TW	-	-	-	6.00	3.70	3.40	3.20
7/16	14	9/16 X 12	0.56	33/64	3632-7/16TW	-	-	-	7.80	4.80	4.30	4.10
1/2	13	5/8 X 11	0.62	37/64	3632-1/2TW	-	-	-	9.20	5.60	5.20	4.90

UNF – THIN WALL CARBON STEEL BULK INSERTS												
						€ EACH	€ EACH	€ EACH	€ EACH	€ EACH	€ EACH	€ EACH
INCH	TPI	INCH X TPI	INCH	INCH	PART #	1	2	3	4	6	100	500
10G	32	5/16 X 18	0.31	I	3634-10GTW	-	-	-	4.80	2.90	2.70	2.50
1/4	28	3/8 X 16	0.37	Q	3634-1/4TW	-	-	-	5.10	3.10	2.80	2.70
5/16	24	7/16 X 14	0.43	X	3634-5/16TW	-	-	-	5.40	3.30	3.00	2.80
3/8	24	1/2 X 13	0.50	29/64	3634-3/8TW	-	-	-	6.00	3.70	3.40	3.20
7/16	20	9/16 X 12	0.56	33/64	3634-7/16TW	-	-	-	7.80	4.80	4.30	4.10
1/2	20	5/8 X 11	0.62	37/64	3634-1/2TW	-	-	-	9.20	5.60	5.20	4.90

Loksert
Loksert solid keylocking inserts are an easily installed thread assembly that is ideal for replacing damaged or worn threads in virtually any material – ferrous, non-ferrous and non-metallic.

They are constructed from high quality carbon steel or extremely hard wearing stainless steel. One piece Loksert inserts are supplied with the dove-tailed locking keys pre-assembled. The pre-positioned keys automatically position the insert at the correct depth below the surface of the parent material. Lokserts are suitable for repairing and creating threads in a wide range of applications including forgings and castings and are especially suited to situations that experience heavy wear and vibration - such as mining, construction and earthmoving equipment.



**MC
MF
UNC
UNF**

GROUP	PSSI
INSERT TYPE	SOLID KEYLOCKING
INSERT MATERIAL	STAINLESS STEEL
STYLE	THIN WALL

METRIC COARSE – THIN WALL STAINLESS STEEL BULK INSERTS

						€ EACH	€ EACH	€ EACH	€ EACH	€ EACH	€ EACH	€ EACH
MM	MM	MM X MM	MM	MM	PART #	1	2	3	4	6	100	500
5.00	0.80	10.00 X 1.25	8.00	6.9	3720-5.00TW	–	22.90	22.90	22.90	10.60	8.10	5.90
6.00	1.00	12.00 X 1.25	10.00	8.8	3720-6.00TW	–	23.20	23.20	23.20	10.40	7.90	5.70
8.00	1.25	14.00 X 1.50	12.00	10.8	3720-8.00TW	–	24.60	24.60	24.60	10.90	8.30	6.00
10.00	1.50	16.00 X 1.50	14.00	12.8	3720-10.00TW	–	27.00	27.00	27.00	12.40	9.80	7.00
12.00	1.75	18.00 X 1.50	16.00	14.75	3720-12.00TW	–	30.90	30.90	30.90	15.60	12.40	9.20

METRIC FINE – THIN WALL STAINLESS STEEL BULK INSERTS

						€ EACH	€ EACH	€ EACH	€ EACH	€ EACH	€ EACH	€ EACH
MM	MM	MM X MM	MM	MM	PART #	1	2	3	4	6	100	500
8.00	1.00	14.00 X 1.50	12.00	10.8	3721-8.00TW	–	24.60	24.60	24.60	10.90	8.30	6.00
10.00	1.25	16.00 X 1.50	14.00	12.8	3721-10.00TW	–	27.00	27.00	27.00	12.40	9.80	7.00
12.00	1.25	18.00 X 1.50	16.00	14.75	3721-12.00TW	–	30.90	30.90	30.90	15.60	12.40	9.20

UNC – THIN WALL STAINLESS STEEL BULK INSERTS

						€ EACH	€ EACH	€ EACH	€ EACH	€ EACH	€ EACH	€ EACH
INCH	TPI	INCH X TPI	INCH	INCH	PART #	1	2	3	4	6	100	500
10G	24	5/16 X 18	0.31	I	3732-10GTW	–	–	–	7.80	5.30	4.40	3.60
1/4	20	3/8 X 16	0.37	Q	3732-1/4TW	–	–	–	8.00	5.50	4.60	3.70
5/16	18	7/16 X 14	0.43	X	3732-5/16TW	–	–	13.10	13.10	8.90	7.40	6.00
3/8	16	1/2 X 13	0.50	29/64	3732-3/8TW	–	–	16.00	16.00	10.90	9.10	7.30
7/16	14	9/16 X 12	0.56	33/64	3732-7/16TW	–	23.50	23.50	23.50	15.90	13.30	10.70
1/2	13	5/8 X 11	0.62	37/64	3732-1/2TW	–	24.90	24.90	24.90	16.90	14.10	11.40

UNF – THIN WALL STAINLESS STEEL BULK INSERTS

						€ EACH	€ EACH	€ EACH	€ EACH	€ EACH	€ EACH	€ EACH
INCH	TPI	INCH X TPI	INCH	INCH	PART #	1	2	3	4	6	100	500
10G	32	5/16 X 18	0.31	I	3734-10GTW	–	–	–	7.80	5.30	4.40	3.60
1/4	28	3/8 X 16	0.37	Q	3734-1/4TW	–	–	–	8.00	5.50	4.60	3.70
5/16	24	7/16 X 14	0.43	X	3734-5/16TW	–	–	13.10	13.10	8.90	7.40	6.00
3/8	24	1/2 X 13	0.50	29/64	3734-3/8TW	–	–	16.00	16.00	10.90	9.10	7.30
7/16	20	9/16 X 12	0.56	33/64	3734-7/16TW	–	23.50	23.50	23.50	15.90	13.30	10.70
1/2	20	5/8 X 11	0.62	37/64	3734-1/2TW	–	24.90	24.90	24.90	16.90	14.10	11.40

Loksert Features and Benefits

Solid bushing utilising locking keys provides positive mechanical lock against rotation.

High strength and reliability provides maximum pullout strength.

Installed using standard drills and taps.

Simple installation - no special skills required.

Suitable for use in a wide range of parent materials.

Impossible to cross thread during installation.

Simple removal process if required.

No tang to break and remove.

Available in metric sizes and inch sizes.







Available in Thinwall and Heavy Duty.









GROUP	PSCI
INSERT TYPE	SOLID KEYLOCKING
INSERT MATERIAL	CARBON STEEL
STYLE	HEAVY DUTY



METRIC COARSE – HEAVY DUTY CARBON STEEL BULK INSERTS

						€ EACH	€ EACH	€ EACH	€ EACH	€ EACH	€ EACH	€ EACH
MM	MM	MM	MM	MM	PART #	1	2	3	4	6	100	500
4.00	0.70	8.00 X 1.25	8.00	6.9	3620-4.00HD	-	-	-	14.30	8.70	8.10	7.30
5.00	0.80	10.00 X 1.25	10.00	8.8	3620-5.00HD	-	-	-	7.50	4.60	4.20	3.80
6.00	1.00	12.00 X 1.25	12.00	10.8	3620-6.00HD	-	-	-	8.00	4.90	4.60	4.10
8.00	1.25	14.00 X 1.50	14.00	12.8	3620-8.00HD	-	-	-	8.90	5.50	5.10	4.60
10.00	1.50	16.00 X 1.50	16.00	14.75	3620-10.00HD	-	-	-	11.00	6.80	6.20	5.60
12.00	1.75	18.00 X 1.50	18.00	16.75	3620-12.00HD	-	-	-	14.00	8.50	7.90	7.10
14.00	2.00	20.00 X 1.50	20.00	18.75	3620-14.00HD	-	-	16.90	16.90	10.40	9.60	8.60
16.00	2.00	22.00 X 1.50	22.00	20.5	3620-16.00HD	-	-	19.90	19.90	12.20	11.30	10.10
20.00	2.50	30.00 X 2.00	30.00	28.0	3620-20.00HD	-	34.70	34.70	34.70	21.20	21.20	21.20
24.00	3.00	33.00 X 2.00	33.00	31.0	3620-24.00HD	56.30	56.30	56.30	56.30	38.60	38.60	38.60

METRIC FINE – HEAVY DUTY CARBON STEEL BULK INSERTS

						€ EACH	€ EACH	€ EACH	€ EACH	€ EACH	€ EACH	€ EACH
MM	MM	MM	MM	MM	PART #	1	2	3	4	6	100	500
8.00	1.00	14.00 X 1.5	8.00	12.8	3621-8.00HD	-	-	-	8.90	5.50	5.10	4.60
10.00	1.25	16.00 X 1.5	16.00	14.75	3621-10.00HD	-	-	-	11.00	6.80	6.20	5.60
12.00	1.25	18.00 X 1.5	18.00	16.75	3621-12.00HD	-	-	-	14.00	8.50	7.90	7.10
14.00	1.50	20.00 X 1.5	20.00	18.75	3621-14.00HD	-	-	16.90	16.90	10.40	9.60	8.60
16.00	1.50	22.00 X 1.5	22.00	20.5	3621-16.00HD	-	-	19.90	19.90	12.20	11.30	10.10
18.00	1.50	24.00 X 1.5	24.00	22.5	3621-18.00HD	-	29.70	29.70	29.70	18.20	16.80	15.10
20.00	1.50	30.00 X 2.0	30.00	28.0	3621-20.00HD	-	34.70	34.70	34.70	21.20	21.20	21.20
22.00	1.50	32.00 X 2.0	32.00	30.0	3621-22.00HD	42.10	42.10	42.10	42.10	25.80	25.80	25.80
24.00	2.00	33.00 X 2.0	33.00	31.0	3621-24.00HD	56.30	56.30	56.30	56.30	38.60	38.60	38.60

Loksert
Loksert solid keylocking inserts are an easily installed thread assembly that is ideal for replacing damaged or worn threads in virtually any material – ferrous, non-ferrous and non-metallic.

They are constructed from high quality carbon steel or extremely hard wearing stainless steel. One piece Loksert inserts are supplied with the dove-tailed locking keys pre-assembled. The pre-positioned keys automatically position the insert at the correct depth below the surface of the parent material. Lokserts are suitable for repairing and creating threads in a wide range of applications including forgings and castings and are especially suited to situations that experience heavy wear and vibration - such as mining, construction and earthmoving equipment.

INSTALLATION



1 DRILL
Drill to clear the damaged thread with a standard twist drill. Chamfer the hole with a standard countersink (82° - 100°)



Note: Drill is oversize to accommodate external thread. Check technical charts for correct drill sizes.



2 TAP
Create new thread using a standard tap. Check technical charts for correct tap size.



Note: Use of a suitable lubricant is essential during all tapping procedures.

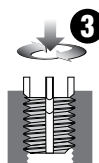

3 INSERT
Screw the insert into the threaded hole until slightly below the surface of the parent material.

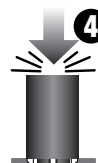

4 DRIVE
Select the correct size installation tool and place over the insert. Drive locking keys down using several hammer taps on end of installation tool.



GROUP	PSCI
INSERT TYPE	SOLID KEYLOCKING
INSERT MATERIAL	CARBON STEEL
STYLE	HEAVY DUTY



UNC – HEAVY DUTY CARBON STEEL BULK INSERTS

INCH	TPI	INCH X TPI	INCH	INCH	PART #	€	€	€	€	€	€	€
						EACH	EACH	EACH	EACH	EACH	EACH	EACH
8G	32	5/16 X 18	0.31	I	3632-8GHD	-	-	-	6.50	4.00	3.60	3.40
10G	24	3/8 X 16	0.31	Q	3632-10GHD	-	-	-	4.80	2.90	2.70	2.50
1/4	20	7/16 X 14	0.37	X	3632-1/4HD	-	-	-	5.10	3.10	2.80	2.70
5/16	18	1/2 X 13	0.43	29/64	3632-5/16HD	-	-	-	5.40	3.30	3.00	2.80
3/8	16	9/16 X 12	0.5	33/64	3632-3/8HD	-	-	-	6.00	3.70	3.40	3.20
7/16	14	5/8 X 11	0.62	37/64	3632-7/16HD	-	-	-	7.80	4.80	4.30	4.10
1/2	13	3/4 X 16	0.62	45/64	3632-1/2HD	-	-	-	9.20	5.60	5.20	4.90
9/16	12	3/4 X 16	0.81	45/64	3632-9/16HD	-	-	12.50	12.50	7.70	7.00	6.60
5/8	11	7/8 X 14	0.87	53/64	3632-5/8HD	-	-	14.60	14.60	8.90	8.10	7.60
3/4	10	1-1/8 X 12	1.12	1-1/16	3632-3/4HD	-	20.80	20.80	20.80	12.70	11.60	10.90
7/8	9	1-1/4 X 12	1.25	1-3/16	3632-7/8HD	-	27.00	27.00	27.00	16.50	15.10	14.20
1	8	1-3/8 X 12	1.37	1-5/16	3632-1HD	54.60	54.60	54.60	54.60	33.40	30.40	28.60
1-1/8	7	1-1/2 X 12	1.62	1-7/16	3632-1.1/8HD	131.30	131.30	131.30	131.30	80.20	73.30	73.30
1-1/4	7	1-5/8 X 12	1.81	1-9/16	3632-1.1/4HD	161.20	161.20	161.20	161.20	98.50	98.50	98.50
1-1/2	6	1-7/8 X 12	2	1-13/16	3632-1.1/2HD	310.50	310.50	310.50	310.50	310.50	310.50	310.50

UNF – HEAVY DUTY CARBON STEEL BULK INSERTS

INCH	TPI	INCH X TPI	INCH	INCH	PART #	€	€	€	€	€	€	€
						EACH	EACH	EACH	EACH	EACH	EACH	EACH
10G	32	3/8 X 16	0.31	Q	3634-10GHD	-	-	-	4.80	2.90	2.70	2.50
1/4	28	7/16 X 14	0.37	X	3634-1/4HD	-	-	-	5.10	3.10	2.80	2.70
5/16	24	1/2 X 13	0.43	29/64	3634-5/16HD	-	-	-	5.40	3.30	3.00	2.80
3/8	24	9/16 X 12	0.5	33/64	3634-3/8HD	-	-	-	6.00	3.70	3.40	3.20
7/16	20	5/8 X 11	0.62	37/64	3634-7/16HD	-	-	-	7.80	4.80	4.30	4.10
1/2	20	3/4 X 16	0.62	45/64	3634-1/2HD	-	-	-	9.20	5.60	5.20	4.90
9/16	18	3/4 X 16	0.81	45/64	3634-9/16HD	-	-	12.50	12.50	7.70	7.00	6.60
5/8	18	7/8 X 14	0.87	53/64	3634-5/8HD	-	-	14.60	14.60	8.90	8.10	7.60
3/4	16	1-1/8 X 12	1.12	1-1/16	3634-3/4HD	-	20.80	20.80	20.80	12.70	11.60	10.90
7/8	14	1-1/4 X 12	1.25	1-3/16	3634-7/8HD	-	27.00	27.00	27.00	16.50	15.10	14.20
1	12	1-3/8 X 12	1.37	1-5/16	3634-1HD	54.60	54.60	54.60	54.60	33.40	30.40	28.60
1	14	1-3/8 X 12	1.37	1-5/16	3635-1HD	54.60	54.60	54.60	54.60	33.40	30.40	30.40
1-1/8	12	1-1/2 X 12	1.62	1-7/16	3634-1.1/8HD	131.30	131.30	131.30	131.30	80.20	73.30	73.30
1-1/4	12	1-5/8 X 12	1.81	1-9/16	3634-1.1/4HD	161.20	161.20	161.20	161.20	98.50	98.50	98.50
1-1/2	12	1-7/8 X 12	2	1-13/16	3634-1.1/2HD	310.50	310.50	310.50	310.50	310.50	310.50	310.50

Loksert Features and Benefits

Solid bushing utilising locking keys provides positive mechanical lock against rotation.

High strength and reliability provides maximum pullout strength.

Installed using standard drills and taps.

Simple installation - no special skills required.

Suitable for use in a wide range of parent materials.

Impossible to cross thread during installation.

Simple removal process if required.

No tang to break and remove.

Available in metric sizes and inch sizes.

Available in Thinwall and Heavy Duty.

REMOVAL



1 DRILL
Drill out the material between the locking keys and the internal thread to the specified depth.

Note: Drill size and drilling depth are shown in the Loksert technical tables.

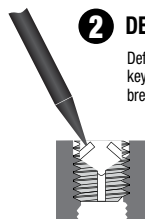

2 DEFLECT
Deflect locking keys inward and break off

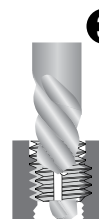

3 REMOVE
Remove the insert from the hole by winding it out using a screw extractor or similar type tool.

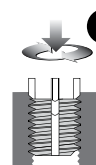







4 INSERT
A new Loksert insert of exactly the same size can be installed in the original hole.









GROUP	PSSI
INSERT TYPE	SOLID KEYLOCKING
INSERT MATERIAL	STAINLESS STEEL
STYLE	HEAVY DUTY



METRIC COARSE – HEAVY DUTY STAINLESS STEEL BULK INSERTS

						€ EACH	€ EACH	€ EACH	€ EACH	€ EACH	€ EACH	€ EACH
MM	MM	MM	MM	MM	PART #	1	2	3	4	6	100	500
4.00	0.70	8.00 X 1.25	8.00	6.9	3720-4.00HD	–	23.70	23.70	23.70	11.40	9.50	7.60
5.00	0.80	10.00 X 1.25	10.00	8.8	3720-5.00HD	–	22.90	22.90	22.90	10.60	8.10	5.90
6.00	1.00	12.00 X 1.25	12.00	10.8	3720-6.00HD	–	23.20	23.20	23.20	10.40	7.90	5.70
8.00	1.25	14.00 X 1.50	14.00	12.8	3720-8.00HD	–	24.60	24.60	24.60	10.90	8.30	6.00
10.00	1.50	16.00 X 1.50	16.00	14.75	3720-10.00HD	–	27.00	27.00	27.00	12.40	9.80	7.00
12.00	1.75	18.00 X 1.50	18.00	16.75	3720-12.00HD	–	30.90	30.90	30.90	15.60	12.40	9.20
14.00	2.00	20.00 X 1.50	20.00	18.75	3720-14.00HD	39.40	39.40	39.40	39.40	20.60	16.40	12.60
16.00	2.00	22.00 X 1.50	22.00	20.5	3720-16.00HD	42.10	42.10	42.10	42.10	22.70	18.30	14.10
20.00	2.50	30.00 X 2.00	30.00	28	3720-20.00HD	62.80	62.80	62.80	62.80	40.00	40.00	40.00
24.00	3.00	33.00 X 2.00	33.00	31	3720-24.00HD	106.70	106.70	106.70	106.70	106.70	106.70	106.70

METRIC FINE – HEAVY DUTY STAINLESS STEEL BULK INSERTS

						€ EACH	€ EACH	€ EACH	€ EACH	€ EACH	€ EACH	€ EACH
MM	MM	MM	MM	MM	PART #	1	2	3	4	6	100	500
8.00	1.00	14.00 X 1.5	8.00	12.8	3721-8.00HD	–	24.60	24.60	24.60	10.90	8.30	6.00
10.00	1.25	16.00 X 1.5	16.00	14.75	3721-10.00HD	–	27.00	27.00	27.00	12.40	9.80	7.00
12.00	1.25	18.00 X 1.5	18.00	16.75	3721-12.00HD	–	30.90	30.90	30.90	15.60	12.40	9.20
14.00	1.50	20.00 X 1.5	20.00	18.75	3721-14.00HD	39.40	39.40	39.40	39.40	20.60	16.40	12.60
16.00	1.50	22.00 X 1.5	22.00	20.5	3721-16.00HD	42.10	42.10	42.10	42.10	22.70	18.30	14.10
18.00	1.50	24.00 X 1.5	24.00	22.5	3721-18.00HD	53.40	53.40	53.40	53.40	32.60	32.60	32.60
20.00	1.50	30.00 X 2.0	30.00	28	3721-20.00HD	62.80	62.80	62.80	62.80	40.00	40.00	40.00
22.00	1.50	32.00 X 2.0	32.00	30	3721-22.00HD	85.40	85.40	85.40	85.40	85.40	85.40	85.40
24.00	2.00	33.00 X 2.0	33.00	31	3721-24.00HD	106.70	106.70	106.70	106.70	106.70	106.70	106.70



Loksert
Loksert solid keylocking inserts are an easily installed thread assembly that is ideal for replacing damaged or worn threads in virtually any material – ferrous, non-ferrous and non-metallic.

They are constructed from high quality carbon steel or extremely hard wearing stainless steel. One piece Loksert inserts are supplied with the dove-tailed locking keys pre-assembled. The pre-positioned keys automatically position the insert at the correct depth below the surface of the parent material. Lokserts are suitable for repairing and creating threads in a wide range of applications including forgings and castings and are especially suited to situations that experience heavy wear and vibration - such as mining, construction and earthmoving equipment.

GROUP	PSSI
INSERT TYPE	SOLID KEYLOCKING
INSERT MATERIAL	STAINLESS STEEL
STYLE	HEAVY DUTY

UNC – HEAVY DUTY STAINLESS STEEL BULK INSERTS

														€ EACH	€ EACH	€ EACH	€ EACH	€ EACH	€ EACH	€ EACH	
INCH	TPI	INCH X TPI	INCH	INCH	PART #	1	2	3	4	6	100	500									
8G	32	5/16 X 18	0.31	I	3732-8GHD	–	–	–	7.50	4.70	4.00	3.30									
10G	24	3/8 X 16	0.31	Q	3732-10GHD	–	–	–	7.80	5.30	4.40	3.60									
1/4	20	7/16 X 14	0.37	X	3732-1/4HD	–	–	–	8.00	5.50	4.60	3.70									
5/16	18	1/2 X 13	0.43	29/64	3732-5/16HD	–	–	–	13.10	8.90	7.40	6.00									
3/8	16	9/16 X 12	0.5	33/64	3732-3/8HD	–	–	–	16.00	10.90	9.10	7.30									
7/16	14	5/8 X 11	0.62	37/64	3732-7/16HD	–	–	–	23.50	15.90	13.30	10.70									
1/2	13	3/4 X 16	0.62	45/64	3732-1/2HD	–	–	–	24.90	16.90	14.10	11.40									
9/16	12	3/4 X 16	0.81	45/64	3732-9/16HD	–	–	28.50	28.50	17.90	15.00	12.50									
5/8	11	7/8 X 14	0.87	53/64	3732-5/8HD	–	–	35.90	35.90	22.50	18.90	15.80									
3/4	10	1-1/8 X 12	1.12	1-1/16	3732-3/4HD	–	42.10	42.10	42.10	26.50	22.20	18.60									
7/8	9	1-1/4 X 12	1.25	1-3/16	3732-7/8HD	–	79.10	79.10	79.10	49.70	49.70	49.70									
1	8	1-3/8 X 12	1.37	1-5/16	3732-1HD	100.20	100.20	100.20	100.20	100.20	100.20	100.20									

UNF – HEAVY DUTY STAINLESS STEEL BULK INSERTS

														€ EACH	€ EACH	€ EACH	€ EACH	€ EACH	€ EACH	€ EACH	
INCH	TPI	INCH X TPI	INCH	INCH	PART #	1	2	3	4	6	100	500									
10G	32	3/8 X 16	0.31	Q	3734-10GHD	–	–	7.80	7.80	5.30	4.40	3.60									
1/4	28	7/16 X 14	0.37	X	3734-1/4HD	–	–	8.00	8.00	5.50	4.60	3.70									
5/16	24	1/2 X 13	0.43	29/64	3734-5/16HD	–	13.10	13.10	13.10	8.90	7.40	6.00									
3/8	24	9/16 X 12	0.5	33/64	3734-3/8HD	–	16.00	16.00	16.00	10.90	9.10	7.30									
7/16	20	5/8 X 11	0.62	37/64	3734-7/16HD	–	23.50	23.50	23.50	15.90	13.30	10.70									
1/2	20	3/4 X 16	0.62	45/64	3734-1/2HD	–	24.90	24.90	24.90	16.90	14.10	11.40									
9/16	18	3/4 X 16	0.81	45/64	3734-9/16HD	–	28.50	28.50	28.50	17.90	15.00	12.50									
5/8	18	7/8 X 14	0.87	53/64	3734-5/8HD	–	35.90	35.90	35.90	22.50	18.90	15.80									
3/4	16	1-1/8 X 12	1.12	1-1/16	3734-3/4HD	–	42.10	42.10	42.10	26.50	22.20	18.60									
7/8	14	1-1/4 X 12	1.25	1-3/16	3734-7/8HD	79.10	79.10	79.10	79.10	49.70	49.70	49.70									
1	12	1-3/8 X 12	1.37	1-5/16	3734-1HD	100.20	100.20	100.20	100.20	100.20	100.20	100.20									

Loksert Features and Benefits

Solid bushing utilising locking keys provides positive mechanical lock against rotation.

High strength and reliability provides maximum pullout strength.

Installed using standard drills and taps.

Simple installation - no special skills required.

Suitable for use in a wide range of parent materials.

Impossible to cross thread during installation.

Simple removal process if required.

No tang to break and remove.

Available in metric sizes and inch sizes.

Available in Thinwall and Heavy Duty.



**MC
MF
UNC
UNF**

Loksert

Loksert solid keylocking inserts are an easily installed thread assembly that is ideal for replacing damaged or worn threads in virtually any material – ferrous, non-ferrous and non-metallic.

They are constructed from high quality carbon steel or extremely hard wearing stainless steel. One piece Loksert inserts are supplied with the dove-tailed locking keys pre-assembled. The pre-positioned keys automatically position the insert at the correct depth below the surface of the parent material. Lokserts are suitable for repairing and creating threads in a wide range of applications including forgings and castings and are especially suited to situations that experience heavy wear and vibration - such as mining, construction and earthmoving equipment.

GROUP	PSCI	PSCI
TO SUIT INSERT TYPE	THINWALL	THINWALL
TAP / DRILL MATERIAL	HSS	HSS
TAP LEAD TYPE	INTERMEDIATE 4-5	-
DRILL POINT TYPE	-	118° SPLIT POINT / 118° NOTCHED POINT



METRIC COARSE AND METRIC FINE

MM	MM	MM X MM	MM	€	PART #	MM	€	PART #
5.00	0.80	8.00 X 1.25	72.00	7.15	3620-8.00I	6.90	5.07	3620-6.9
6.00	1.00	10.00 X 1.25	76.00	18.18	3621-10.00I	8.80	8.14	3620-8.8
8.00	1.25	12.00 X 1.25	84.00	20.88	3622-12.00I	10.80	18.04	3620-10.8
10.00	1.50	14.00 X 1.50	95.00	28.29	3621-14.00I	12.80	26.23	3620-12.8
12.00	1.75	16.00 X 1.50	102.00	30.82	3621-16.00I	14.75	27.42	3620-14.75*

UNC AND UNF

INCH	TPI	INCH X TPI	MM	€	PART #	INCH	€	PART #
10G	24	5/16 X 18	72.00	7.15	3632-5/16I	I	4.28	3632-I
1/4	20	3/8 X 16	80.00	9.78	3632-3/8I	Q	6.05	3632-Q
5/16	18	7/16 X 14	85.00	13.17	3632-7/16I	X	10.33	3632-X
3/8	16	1/2 X 13	89.00	14.49	3632-1/2I	29/64	14.25	3632-29/64
7/16	14	9/16 X 12	95.00	20.92	3632-9/16I	33/64	27.42	3632-33/64*
1/2	13	5/8 X 11	102.00	22.05	3632-5/8I	37/64	34.42	3632-37/64*

* Supplied as Reduced Shank HSS 118° notched point drill.

HSS 118° Split Point Jobber Drill – Bright Finish



HSS 118° Notched Point Reduced Shank Drill – Bright/Black Finish



HSS 118° Notched Point Morse Taper Shank Drill – Black Finish





GROUP	PSCI	PSCI
TO SUIT INSERT TYPE	HEAVY DUTY	HEAVY DUTY
TAP / DRILL MATERIAL	HSS	HSS
TAP LEAD TYPE	INTERMEDIATE 4-5	-
DRILL POINT TYPE	-	118° SPLIT POINT / 118° NOTCHED POINT

METRIC COARSE & METRIC FINE

MM	MM X MM	MM	€	PART #	MM	€	PART #
4.00	8.00 X 1.25	72.00	7.15	3620-8.00I	6.90	5.07	3620-6.9
5.00	10.00 X 1.25	76.00	18.18	3621-10.00I	8.80	8.14	3620-8.8
6.00	12.00 X 1.25	84.00	20.88	3622-12.00I	10.80	18.04	3620-10.8
8.00	14.00 X 1.50	95.00	28.29	3621-14.00I	12.80	26.23	3620-12.8
10.00	16.00 X 1.50	102.00	30.82	3621-16.00I	14.75	27.42	3620-14.75*
12.00	18.00 X 1.50	104.00	68.18	3622-18.00I	16.75	42.62	3620-16.75*
14.00	20.00 X 1.50	104.00	85.26	3623-20.00I	18.75	43.61	3620-18.75*
16.00	22.00 X 1.50	113.00	102.16	3621-22.00I	20.50	53.72	3620-20.50*
18.00	24.00 X 1.50	120.00	106.21	3624-24.00I	22.50	59.17	3620-22.50*
20.00	30.00 X 2.00	127.00	130.42	3621-30.00I	28.00	96.55	3620-28.00*
22.00	32.00 X 2.00	137.00	191.27	3622-32.00I	30.00	101.22	3620-30.00*
24.00	33.00 X 2.00	137.00	191.27	3621-33.00I	31.00	106.95	3620-31.00*

Loksert Features and Benefits

Solid bushing utilising locking keys provides positive mechanical lock against rotation.

High strength and reliability provides maximum pullout strength.

Installed using standard drills and taps.

Simple installation - no special skills required.

Suitable for use in a wide range of parent materials.

Impossible to cross thread during installation.

Simple removal process if required.

No tang to break and remove.

Available in metric sizes and inch sizes.

Available in Thinwall and Heavy Duty.

UNC & UNF

INCH	INCH X TPI	MM	€	PART #	INCH	€	PART #
8G	5/16 X 18	72.00	7.15	3632-5/16I	I	4.28	3632-I
10G	3/8 X 16	80.00	9.78	3632-3/8I	Q	6.05	3632-Q
1/4	7/16 X 14	85.00	13.17	3632-7/16I	X	10.33	3632-X
5/16	1/2 X 13	89.00	14.49	3632-1/2I	29/64	14.25	3632-29/64
3/8	9/16 X 12	95.00	20.92	3632-9/16I	33/64	27.42	3632-33/64*
7/16	5/8 X 11	102.00	22.05	3632-5/8I	37/64	34.42	3632-37/64*
1/2	3/4 X 16	104.00	49.18	3632-3/4I	45/64	44.64	3632-45/64*
9/16	3/4 X 16	104.00	49.18	3632-3/4I	45/64	44.64	3632-45/64*
5/8	7/8 X 14	113.00	68.52	3632-7/8I	53/64	56.55	3632-53/64*
3/4	1-1/8 X 12	127.00	145.76	3632-1.1/8I	1-1/16	90.33	3632-1.1/16*
7/8	1-1/4 X 12	137.00	162.84	3632-1.1/4I	1-3/16	101.22	3632-1.3/16*
1	1-3/8 X 12	144.00	216.23	3632-1.3/8I	1-5/16	192.02	3632-1.5/16**
1-1/8	1-1/2 X 12	149.00	242.37	3632-1.1/2I	1-7/16	250.21	3632-1.7/16**
1-1/4	1-5/8 X 12	170.00	272.56	3632-1.5/8I	1-9/16	286.69	3632-1.9/16**
1-1/2	1-7/8 X 12	186.00	356.04	3632-1.7/8I	1-13/16	337.23	3632-1.13/16**

* Supplied as Reduced Shank HSS 118° notched point drill.

** Supplied as Morse Taper Shank (MTS) HSS 118° notched point drill.

GROUP	PSIT
INSERT TYPE	SOLID KEYLOCKING
INSERT MATERIAL	CARBON & STAINLESS STEEL



METRIC – INSTALLATION TOOLS

UNIVERSAL TOOL		THIN WALL TOOL		HEAVY DUTY TOOL		
MM	€	PART #	€	PART #	€	PART #
4.00	–	–	–	–	37.70	3600-4.00HT
5.00	21.40	3600-190T	38.30	3600-5.00TT	38.30	3600-5.00HT
6.00	19.60	3600-250T	39.40	3600-6.00TT	39.40	3600-6.00HT
8.00	23.50	3600-312T	40.90	3600-8.00TT	40.90	3600-8.00HT
10.00	23.50	3600-375T	44.20	3600-10.00TT	44.20	3600-10.00HT
12.00	25.75	3600-500T	47.40	3600-12.00TT	47.40	3600-12.00HT
14.00	–	–	–	–	51.60	3600-14.00HT
16.00	25.75	3600-625T	–	–	53.40	3600-16.00HT
18.00	–	–	–	–	54.80	3600-18.00HT
20.00	30.30	3600-875T	–	–	56.90	3600-20.00HT
22.00	–	–	–	–	58.70	3600-22.00HT
24.00	–	–	–	–	64.90	3600-24.00HT

Loksert

Loksert solid keylocking inserts are an easily installed thread assembly that is ideal for replacing damaged or worn threads in virtually any material – ferrous, non-ferrous and non-metallic.

They are constructed from high quality carbon steel or extremely hard wearing stainless steel. One piece Loksert inserts are supplied with the dove-tailed locking keys pre-assembled. The pre-positioned keys automatically position the insert at the correct depth below the surface of the parent material. Lokserts are suitable for repairing and creating threads in a wide range of applications including forgings and castings and are especially suited to situations that experience heavy wear and vibration - such as mining, construction and earthmoving equipment.

UNC / UNF – INSTALLATION TOOLS

UNIVERSAL TOOL		THIN WALL TOOL		HEAVY DUTY TOOL		
INCH	€	PART #	€	PART #	€	PART #
8G	–	–	–	–	74.40	3600-8GHT
10G	21.40	3600-190T	58.40	3600-10GTT	64.30	3600-10GHT
1/4	19.60	3600-250T	55.70	3600-1/4TT	46.90	3600-1/4HT
5/16	23.50	3600-312T	46.90	3600-5/16TT	46.90	3600-5/16HT
3/8	23.50	3600-375T	70.30	3600-3/8TT	49.80	3600-3/8HT
7/16	23.50	3600-375T	70.50	3600-7/16TT	51.00	3600-7/16HT
1/2	25.75	3600-500T	51.00	3600-1/2TT	55.70	3600-1/2HT
9/16	25.75	3600-500T	–	–	55.70	3600-9/16HT
5/8	25.75	3600-625T	–	–	64.30	3600-5/8HT
3/4	30.30	3600-875T	–	–	74.40	3600-3/4HT
7/8	30.30	3600-875T	–	–	78.80	3600-7/8HT
1	30.30	3600-100T	–	–	93.10	3600-1HT
1-1/8	–	–	–	–	219.20	3600-1.1/8HT
1-1/4	–	–	–	–	237.00	3600-1.1/4HT
1-1/2	–	–	–	–	278.80	3600-1.1/2HT

tapsert 
®

 **BORDO**
INDUSTRIAL TOOLS



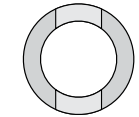
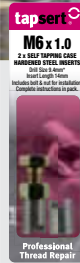

**MC
SPARK
UNC
UNF**

Tapserts

Tapserts are self cutting threaded inserts that feature both external and internal threads. They are driven into a pre-formed or pre-drilled retaining hole and the cutting slots (or cutting bores) effectively tap the hole as the insert is wound into the parent material.

Tapserts are ideal for use in low shear strength materials (such as alloys, plastics and castings) which require threaded seats with high load capacity and wear resistance.

Tapserts feature:

- High pull-out strength
- High loading capacity in low shear strength materials
- Wear free, vibration resistant screw joint
- Pre-cast or pre-drilled holes with standard tolerance
- No requirement for expensive thread tapping tools
- Retains and captures chips from installation in chipping reservoirs.

GROUP	STSI
INSERT TYPE	SELF TAPPING
INSERT MATERIAL	CASE HARDENED STEEL
FINISH	YELLOW ZINC PASSIVATED

METRIC							
MM	MM	MM X MM	MM	€	PART #	#	MM
2.50	0.45	4.50 X 0.50	6	7.73	3920-2.5X6P	2	4.3*
3.00	0.50	5.00 X 0.50	6	7.73	3920-3X6P	2	4.8*
4.00	0.70	6.50 X 0.75	8	7.03	3920-4X8P	2	6.2*
5.00	0.80	8.00 X 1.00	10	7.03	3920-5X10P	2	7.6*
6.00	1.00	10.00 X 1.50	14	7.03	3920-6X14P	2	9.4*
8.00	1.25	12.00 X 1.50	15	7.73	3920-8X15P	2	11.4*
10.00	1.50	14.00 X 1.50	18	8.43	3920-10X18P	2	13.4*
12.00	1.75	16.00 X 1.50	22	9.84	3920-12X22P	2	15.4*
14.00	2.00	18.00 X 1.50	24	10.28	3920-14X24P	2	17.4*
16.00	1.50	20.00 X 1.50	22	14.76	3921-16X22P	2	19.4*
16.00	2.00	20.00 X 1.50	22	14.76	3920-16X22P	2	19.4*

SPARK PLUG							
MM	MM	MM X MM	MM	€	PART #	#	MM
14.00	1.25	17.70 X 1.25	9	12.30	3922-14X9P	2	17.4*
14.00	1.25	17.70 X 1.25	15	13.00	3922-14X15P	2	17.4*
14.00	1.25	17.70 X 1.25	9 & 15	13.00	3922-14CP	1 EACH	17.4*

UNC							
INCH	TPI	MM X MM	MM	€	PART #	#	MM
4G	40	5.00 X 0.50	6	6.22	3932-4GX6P	2	4.8*
6G	32	6.00 X 0.75	8	6.22	3932-6GX8P	2	5.7*
8G	32	6.50 X 0.75	8	6.22	3932-8GX8P	2	6.2*
10G	24	8.00 X 1.00	10	6.22	3932-10GX10P	2	7.6*
1/4	20	10.00 X 1.50	14	7.03	3932-1/4X14P	2	9.4*
5/16	18	12.00 X 1.50	15	7.73	3932-5/16X15P	2	11.4*
3/8	16	14.00 X 1.50	18	8.43	3932-3/8X18P	2	13.4*
7/16	14	16.00 X 1.50	22	9.14	3932-7/16X22P	2	15.4*
1/2	13	18.00 X 1.50	22	9.84	3932-1/2X22P	2	17.4*
5/8	11	20.00 X 1.50	22	10.96	3932-5/8X22P	2	19.4*

UNF							
INCH	TPI	MM X MM	MM	€	PART #	#	MM
10G	32	8.00 X 1.00	10	6.22	3934-10GX10P	2	7.6*
1/4	28	10.00 X 1.50	14	7.03	3934-1/4X14P	2	9.4*
5/16	24	12.00 X 1.50	15	7.73	3934-5/16X15P	2	11.4*
3/8	24	14.00 X 1.50	18	8.43	3934-3/8X18P	2	13.4*
7/16	20	16.00 X 1.50	22	9.14	3934-7/16X22P	2	15.4*
1/2	20	18.00 X 1.50	22	9.84	3934-1/2X22P	2	17.4*
5/8	18	20.00 X 1.50	22	10.96	3934-5/8X22P	2	19.4*

* Tapping drill not included in kit.

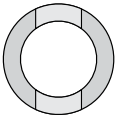

GROUP	STSI
INSERT TYPE	SELF TAPPING
INSERT MATERIAL	CASE HARDENED STEEL
FINISH	YELLOW ZINC PASSIVATED



MERCHANDISER				
	€	PART #	#	PART #
TAPSERT HANG SELL MERCHANDISER	380.22	3900-D1	2	3920-3X6P
			2	3920-4X8P
			2	3920-5X10P
			2	3920-6X14P
			2	3920-8X15P
			2	3920-10X18P
			2	3920-12X22P
			2	3920-16X22P
			2	3921-16X22P
			2	3922-14X15P
			2	3922-14X9P
			2	3922-14CP
			2	3932-1/4X14P
			2	3932-5/16X15P
			2	3932-3/8X18P
			2	3932-7/16X22P
			2	3932-1/2X22P
			2	3934-5/16x15P
			2	3934-3/8X18P

Tapserts

Tapserts are self cutting threaded inserts that feature both external and internal threads. They are driven into a pre-formed or pre-drilled retaining hole and the cutting slots (or cutting bores) effectively tap the hole as the insert is wound into the parent material. Tapserts are ideal for use in low shear strength materials (such as alloys, plastics and castings) which require threaded seats with high load capacity and wear resistance.

Tapserts feature:
 High pull-out strength
 High loading capacity in low shear strength materials
 Wear free, vibration resistant screw joint

Pre-cast or pre-drilled holes with standard tolerance

No requirement for expensive thread tapping tools

Retains and captures chips from installation in chipping reservoirs.

tapsert[®] INSTALLATION

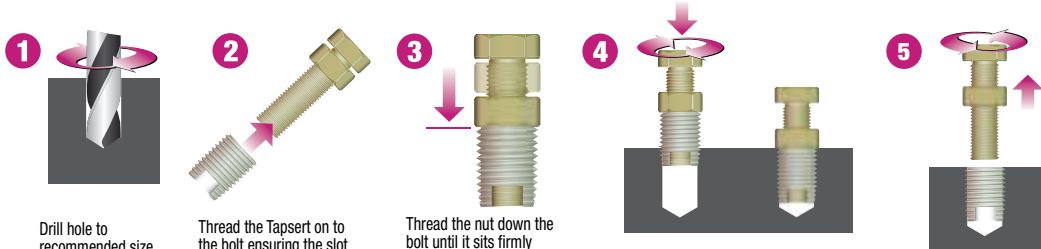

1 Drill hole to recommended size as shown in the selection table.

2 Thread the Tapsert on to the bolt ensuring the slot side is down. The insert should be flush with the end of the bolt.

3 Thread the nut down the bolt until it sits firmly against the top of the Tapsert.

4 To ensure the Tapsert installation is straight apply downward pressure on the assembly. If using an open ended wrench apply downward pressure to the bolt head whilst turning the nut to wind the Tapsert in. Alternatively if using a socket for installation apply downward pressure to the socket.

5 Loosen the nut with an open ended wrench and wind the nut and bolt assembly out of the Tapsert.



NOTE Tapping fluid should be used to aid installation.

The Tapsert is installed when the nut is flush with the top of the parent material.

Congratulations – you have successfully created a new thread.

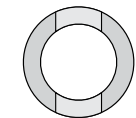

**MC
SPARK
UNC
UNF**

Tapserts

Tapserts are self cutting threaded inserts that feature both external and internal threads. They are driven into a pre-formed or pre-drilled retaining hole and the cutting slots (or cutting bores) effectively tap the hole as the insert is wound into the parent material.

Tapserts are ideal for use in low shear strength materials (such as alloys, plastics and castings) which require threaded seats with high load capacity and wear resistance.

Tapserts feature:

- High pull-out strength
- High loading capacity in low shear strength materials
- Wear free, vibration resistant screw joint
- Pre-cast or pre-drilled holes with standard tolerance
- No requirement for expensive thread tapping tools
- Retains and captures chips from installation in chipping reservoirs.

GROUP	STSI	STSS
INSERT TYPE	SELF TAPPING	SELF TAPPING
INSERT MATERIAL	CASE HARDENED STEEL	STAINLESS STEEL
FINISH	YELLOW ZINC PASSIVATED	BRIGHT

METRIC COARSE								
MM	MM	MM X MM	MM	MM	€	PART #	€	PART #
2.50	0.45	4.50 X 0.50	6	4.3*	0.29	3920-2.5X6	0.51	3920-2.5X6SS
3.00	0.50	5.00 X 0.50	6	4.8*	0.28	3920-3X6	0.52	3920-3X6SS
4.00	0.70	6.50 X 0.75	8	6.2*	0.39	3920-4X8	0.71	3920-4X8SS
5.00	0.80	8.00 X 1.00	10	7.6*	0.51	3920-5X10	1.04	3920-5X10SS
6.00	1.00	10.00 X 1.50	14	9.4*	0.72	3920-6X14	1.38	3920-6X14SS
8.00	1.25	12.00 X 1.50	15	11.4*	0.93	3920-8X15	1.83	3920-8X15SS
10.00	1.50	14.00 X 1.50	18	13.4*	1.32	3920-10X18	2.54	3920-10X18SS
12.00	1.75	16.00 X 1.50	22	15.4*	1.94	3920-12X22	3.81	3920-12X22SS
14.00	2.00	18.00 X 1.50	24	17.4*	2.28	3920-14X24	4.20	3920-14X24SS
16.00	1.50	20.00 X 1.50	22	19.4*	2.57	3921-16X22	-	-
16.00	2.00	20.00 X 1.50	22	19.4*	2.57	3920-16X22	5.46	3920-16X22SS
18.00	2.50	22.00 X 1.50	24	21.4*	3.00	3920-18X24	5.50	3920-18X24SS
20.00	2.50	26.00 X 1.50	27	25.4*	3.52	3920-20X26	6.45	3920-20X26SS
22.00	2.50	26.00 X 1.50	30	25.4*	4.02	3920-22X30	7.37	3920-22X30SS
24.00	3.00	30.00 X 1.50	30	29.4*	4.62	3920-24X30	8.47	3920-24X30SS

SPARK PLUG								
MM	MM	MM X MM	MM	MM	€	PART #	€	PART #
14.00	1.25	17.70 X 1.25	9	17.4*	1.59	3922-14X9	2.76	3922-14X9SS
14.00	1.25	17.70 X 1.25	15	17.4*	2.13	3922-14X15	3.85	3922-14X15SS

UNC								
INCH	TPI	MM X MM	MM	MM	€	PART #	€	PART #
4G	40	5.00 X 0.50	6	4.8*	0.30	3932-4GX6	0.55	3932-4GX6SS
6G	32	6.00 X 0.75	8	5.7*	0.39	3932-6GX8	0.72	3932-6GX8SS
8G	32	6.50 X 0.75	8	6.2*	0.51	3932-8GX8	0.93	3932-8GX8SS
10G	24	8.00 X 1.00	10	7.6*	0.59	3932-10GX10	1.09	3932-10GX10SS
1/4	20	10.00 X 1.50	14	9.4*	0.72	3932-1/4X14	1.38	3932-1/4X14SS
5/16	18	12.00 X 1.50	15	11.4*	0.93	3932-5/16X15	1.83	3932-5/16X15SS
3/8	16	14.00 X 1.50	18	13.4*	1.32	3932-3/8X18	2.62	3932-3/8X18SS
7/16	14	16.00 X 1.50	22	15.4*	1.94	3932-7/16X22	3.81	3932-7/16X22SS
1/2	13	18.00 X 1.50	22	17.4*	2.44	3932-1/2X22	5.08	3932-1/2X22SS
5/8	11	20.00 X 1.50	22	19.4*	2.78	3932-5/8X22	5.09	3932-5/8X22SS

UNF								
INCH	TPI	MM X MM	MM	MM	€	PART #	€	PART #
10G	32	8.00 X 1.00	10	7.6*	0.59	3934-10GX10	1.09	3934-10GX10SS
1/4	28	10.00 X 1.50	14	9.4*	0.72	3934-1/4X14	1.38	3934-1/4X14SS
5/16	24	12.00 X 1.50	15	11.4*	0.93	3934-5/16X15	1.83	3934-5/16X15SS
3/8	24	14.00 X 1.50	18	13.4*	1.32	3934-3/8X18	2.62	3934-3/8X18SS
7/16	20	16.00 X 1.50	22	15.4*	1.94	3934-7/16X22	3.81	3934-7/16X22SS
1/2	20	18.00 X 1.50	22	17.4*	2.44	3934-1/2X22	5.08	3934-1/2X22SS
5/8	18	20.00 X 1.50	22	19.4*	2.78	3934-5/8X22	5.09	3934-5/8X22SS

Nes[®]



MINI KIT 1044

U.S. Pat. No. 5,844,227
Patented in other countries
& (KIT PEND.)

INTERNAL

- 1 Turn handle (A) to remove ThreadMate (B) into housing (C).
- 2 Turn handle (A) to extend handle (B) into a thread groove below the cam (D) without the cam (E) in the hole only.
- 3 Rotate ThreadMate (B) inward as shown.

For internal aluminum threads
please refer to card.

See details and replacing instructions on www.threadmate.com





NES Threadmate

ThreadMate Kits are an economical option for internal M5 - M12 external M4 - M13 and are ideal for:

- Outdoor technicians
- Maintenance Workshops
- Garages
- Marine Repairs
- Agricultural Repairs
- Motorcycles
- Bicycles

NES Threadmate tools are also available individually in convenient clam shell hang packs.

Spare blades are available in 60°, which are supplied as standard, and also 55° to suit BSW and BSF thread forms.

Threadmate kits include replaceable nylon pads to protect thread crests when restoring threads in soft metals and alloys.

GROUP	NESR
THREAD TYPE	EXTERNAL
THREAD ANGLE	60°
THREAD RANGE	4-13MM (5/32-1/2")



THREADMATE					
MM	INCH	€	PART #		
4.00-13.00	5/32-1/2	38.14	3507-06040		

GROUP	NESR
THREAD TYPE	INTERNAL & EXTERNAL
THREAD ANGLE	60°
INTERNAL THREAD RANGE	5-12MM (1/8-1/2")
EXTERNAL THREAD RANGE	4-13MM (5/32-1/2")



THREADMATE KIT										
MM	INCH	MM	INCH	€	PART #					
4.00-13.00	5/32-1/2	5.00-12.00	1/8-1/2	166.93	3507-01044					
						PART #	QTY	MM	INCH	
						3507-06040	1	4-13	5/32-1/2	
						TM20	1	5-8	1/8-1/2	
						TM21	1	8-12	1/4-1/2	
						3507-07207	4	-	-	
						3507-07217	4	-	-	

GROUP	NESR
THREAD TYPE	INTERNAL & EXTERNAL
THREAD ANGLE	60°
INTERNAL THREAD RANGE	5-12MM (1/8-1/2")
EXTERNAL THREAD RANGE	4-13MM (5/32-1/2")



THREADMATE KIT MERCHANDISER						
MM	INCH	MM	INCH	QTY	€	PART #
4.00-13.00	5/32-1/2	5.00-12.00	1/8-1/2	5	795.83	3507-D1

GROUP	NESR
-------	------

THREADMATE							
EXTERNAL	INTERNAL	€	PART #		€	PART #	
-	TM20 NYLON PADS (5)	5.76	3507-07207		-	-	
-	TM21 NYLON PADS (5)	8.24	3507-07217		-	-	
-	60° BLADES	-	-		11.78	3507-06046	
-	55° BLADES	-	-		11.78	3507-06045	

GROUP	NESR
THREAD TYPE	EXTERNAL
THREAD ANGLE	60°

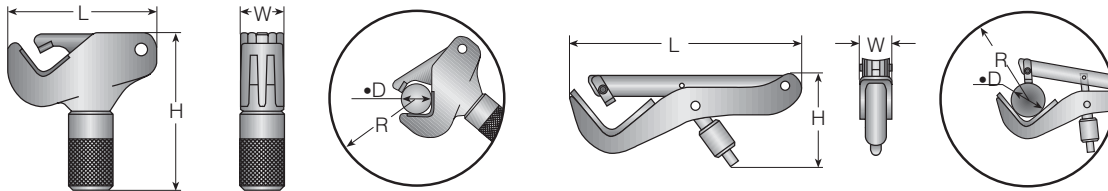

Features and Benefits of NES Adjustable Thread Restoring Tools and Kits

One tool restores Metric, Imperial, Right Hand and Left Hand threads and replaces many taps and/or dies.

Does not require calibration

Self adjusting to any size and pitch within tool range

Hardened HSS cutting blades for long service life

Tool uses undamaged section of thread to guide cutting blades during repair to damaged areas

Removes rust and burrs

Quick to set up and simple to use

Spare cutting blades are available in 60° and 55° flank angles

Repairs a wide range of sizes
Internal 8mm to 108mm
External 4mm to 152mm

EXTERNAL	MIN MAX	MIN MAX	MIN MAX	€	PART #	L	W	H	R
	MM	INCH	PIPE						
NES 1A	4.00 – 18.00	5/32 – 11/16	up to 7/16"	75.43	3507-NES1A	61	23	62	68
NES 2	17.00 – 38.00	11/16 – 1-1/2	3/8" to 1-1/8"	109.94	3507-NES2	105	32	110	117
NES 3	32.00 – 152.00	1-1/4 – 6	1" to 5-1/2"	252.76	3507-NES3	305	44	130	250

KEYWAY SKIP ADAPTOR			
SUITS	€	PART #	
NES 3 PITCH ≥ 1.75MM OR 14TPI	76.40	3507-03101	
NES 3 PITCH < 1.75MM OR 14TPI	131.01	3507-03103	

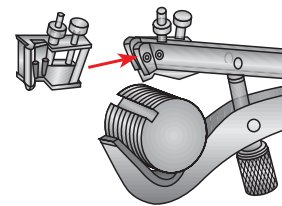

REPLACEMENT BLADES					
		60°		55°	
SUITS	€	PART #		€	PART #
NES 1A ALL PITCHES	28.43	3507-00010		28.43	3507-00020
NES 2 PITCH ≥ 1.5MM OR 17TPI	38.61	3507-00030		38.61	3507-00040
NES 2 PITCH < 1.5MM OR 17TPI	38.61	3507-00031F		38.61	3507-00041F
NES 3 1.75MM 14TPI ≤ PITCH ≤ 3.5MM 7TPI	54.61	3507-03010		54.61	3507-03020
NES 3 PITCH > 3.5MM OR 7TPI	54.61	3507-03011C		54.61	3507-03021C
NES 3 PITCH < 1.75MM OR 14TPI	54.61	3507-03010F		–	–

Nylon Pads

Nylon pads are available for NES 21 through to NES 24 internal tools and are to be used during the repair of threads in aluminium and other soft metals. NES Nylon Pads are produced from top quality polyamide resins which provide superior toughness, resilience and outstanding mechanical properties over a wide range of operating environments.





Features and Benefits of NES Adjustable Thread Restoring Tools and Kits

One tool restores Metric, Imperial, Right Hand and Left Hand threads and replaces many taps and/or dies.

Does not require calibration.

Self adjusting to any size and pitch within tool range.

Hardened HSS cutting blades for long service life.

Tool uses undamaged section of thread to guide cutting blades during repair to damaged areas.

Removes rust and burrs.

Quick to set up and simple to use.

Spare cutting blades are available in 60° and 55° flank angles.

Repairs a wide range of sizes Internal 8mm to 108mm External 4mm to 152mm.

GROUP	NESR
THREAD TYPE	INTERNAL
THREAD ANGLE	60°

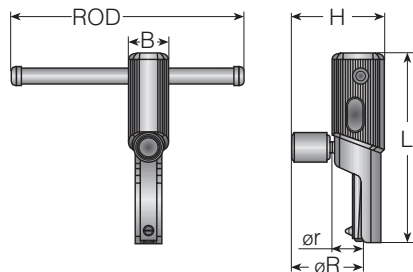

INTERNAL										
	MIN MAX	MIN MAX								
	MM	INCH	€	PART #	L	B	H	ROD	ø r	ø R
NES 21	8.00 – 11.00	5/16 – 7/16	83.32	3507-NES21	109	18	45	136	16	38
NES 22	12.00 – 16.00	1/2 – 5/8	83.32	3507-NES22	109	18	45	136	17	39
NES 23	16.00 – 20.00	11/16 – 13/16	90.90	3507-NES23	111	21	53	146	20	45
NES 24	22.00 – 32.00	7/8 – 1-1/4	121.22	3507-NES24	136	27	64	161	27	54
NES 25	32.00 – 54.00	1-1/4 – 2-1/8	212.21	3507-NES25	163	38	81	192	35	62
NES 26	32.00 – 68.00	1-1/4 – 2-5/8	303.19	3507-NES26	163	50	92	192	41	70
NES 27	69.00 – 81.00	2-3/4 – 3-3/16	394.73	3507-NES27	163	50	103	192	48	76
NES 28	82.00 – 95.00	3-1/4 – 3-3/4	487.49	3507-NES28	163	50	118	192	54	82
NES 29	96.00 – 108.00	3-3/4 – 4-1/4	575.59	3507-NES29	163	50	132	192	61	88

ACCESSORIES						
	MIN MAX					
SUITS	NEW TOOL SIZE RANGE	QTY	€	PART #	€	PART #
NES 21	9-11MM, 3/8-1/2"	5	8.24	3507-07217	–	–
NES 22	14-18MM, 9/16-11/16"	5	8.24	3507-07227	–	–
NES 23	18-22MM, 11/16-7/8"	5	9.26	3507-07237	–	–
NES 24	22-33MM, 7/8-1-5/16"	5	9.92	3507-07247	–	–
NES 25	68MM, 2-5/8"	1	–	–	76.40	3507-07269

REPLACEMENT BLADES					
			60°	55°	
SUITS		€	PART #	€	PART #
NES 21	ALL PITCHES	20.06	3507-07216	20.06	3507-07215
NES 22	ALL PITCHES	18.23	3507-07226	18.23	3507-07225
NES 23	ALL PITCHES	18.84	3507-07236	18.84	3507-07235
NES 24	PITCH ≤ 2.5MM OR 10TPI	19.86	3507-07246F	19.86	3507-07245F
NES 24	PITCH > 2.5MM OR 10TPI	19.86	3507-07246C	19.86	3507-07245C
NES 25	PITCH ≤ 1.75MM OR 14TPI	22.91	3507-07256	22.91	3507-07255
NES 25	PITCH < 1.75MM OR 14TPI	22.93	3507-07256F	22.93	3507-07255F
NES 26	1.75MM 14TPI ≤ PITCH ≤ 3.5MM 7TPI	24.51	3507-07266	22.91	3507-07265
NES 26	PITCH < 1.75MM OR 14TPI	24.51	3507-07266F	22.91	3507-07265F
NES 26	PITCH > 3.5MM OR 7TPI	–	–	22.91	3507-07265C

GROUP	NESR
THREAD TYPE	INTERNAL & EXTERNAL
THREAD ANGLE	60°



MERCHANDISER				
	€	PART #	PART #	PART #
NES HANG SELL MERCHANDISER	579.12	3507-D2	3507-NES21	3507-06040
			3507-NES22	3507-NES1A
			3507-NES23	3507-NES2
			3507-NES24	—





Features and Benefits of NES Adjustable Thread Restoring Tools and Kits

One tool restores Metric, Imperial, Right Hand and Left Hand threads and replaces many taps and/or dies.

Does not require calibration.

Self adjusting to any size and pitch within tool range.

Hardened HSS cutting blades for long service life.

Tool uses undamaged section of thread to guide cutting blades during repair to damaged areas.

Removes rust and burrs.

Quick to set up and simple to use.

Spare cutting blades are available in 60° and 55° flank angles.

Repairs a wide range of sizes
Internal 8mm to 108mm
External 4mm to 152mm.



GROUP	NESR
THREAD TYPE	INTERNAL
THREAD ANGLE	60°
INTERNAL THREAD RANGE	8 – 32MM (5/16 – 1-1/4")

INTERNAL KIT

		Nes®				← MIN MAX →	← MIN MAX →
	€	PART #	PART #	QTY	MM	INCH	
SET 1008	377.66	3507-01008	3507-NES21	1	8.00 – 11.00	5/16 – 7/16	
			3507-NES22	1	12.00 – 16.00	1/2 – 5/8	
			3507-NES23	1	16.00 – 20.00	11/16 – 13/16	
			3507-NES24	1	22.00 – 32.00	7/8 – 1-1/4	
			3507-07216	1	–	–	
			3507-07226	1	–	–	
			3507-07236	1	–	–	
			3507-07246F	1	–	–	



GROUP	NESR
THREAD TYPE	INTERNAL & EXTERNAL
THREAD ANGLE	60°
INTERNAL THREAD RANGE	8 – 32MM (5/16 – 1-1/4")
EXTERNAL THREAD RANGE	4 – 38MM (5/32 – 1-1/2")

COMBINATION KIT

		Nes®				← MIN MAX →	← MIN MAX →	→ MIN MAX ←	→ MIN MAX ←
	€	PART #	PART #	QTY	MM	INCH	MM	INCH	
SET 1025	578.19	3507-01025	3507-NES1A	1	–	–	4.00 – 18.00	5/32 – 11/16	
			3507-NES2	1	–	–	17.00 – 38.00	11/16 – 1-1/2	
			3507-NES21	1	8.00 – 11.00	5/16 – 7/16	–	–	
			3507-NES22	1	12.00 – 16.00	1/2 – 5/8	–	–	
			3507-NES23	1	16.00 – 20.00	11/16 – 13/16	–	–	
			3507-NES24	1	22.00 – 32.00	7/8 – 1-1/4	–	–	
			3507-00010	1	–	–	–	–	
			3507-00030	1	–	–	–	–	
			3507-07216	1	–	–	–	–	
			3507-07226	1	–	–	–	–	
			3507-07236	1	–	–	–	–	
			3507-07246F	1	–	–	–	–	



GROUP	NESR
THREAD TYPE	EXTERNAL
THREAD ANGLE	60°
THREAD RANGE	4 – 38MM (5/32 – 1-1/2")

EXTERNAL KIT						
	Nes®				MIN MAX	MIN MAX
	€	PART #	PART #	QTY	MM	INCH
SET 12	206.71	3507-01000	3507-NES1A	1	4.00 – 18.00	5/32 – 11/16
			3507-NES2	1	17.00 – 38.00	11/16 – 1-1/2
			3507-00010	1	–	–
			3507-00030	1	–	–

GROUP	NESR
THREAD TYPE	EXTERNAL
THREAD ANGLE	60°
THREAD RANGE	4 – 152MM (5/32 – 6")



EXTERNAL KIT						
	Nes®				MIN MAX	MIN MAX
	€	PART #	PART #	QTY	MM	INCH
SET 123	507.55	3507-01300	3507-NES1A	1	4.00 – 18.00	5/32 – 11/16
			3507-NES2	1	17.00 – 38.00	11/16 – 1-1/2
			3507-NES3	1	32.00 – 152.00	1-1/4 – 6
			3507-00010	1	–	–
			3507-00030	1	–	–
			3507-03010	1	–	–
			CLEANER	1	–	–
			EXTENSION HANDLE	1	–	–



Optimum thread performance with Wire Thread Inserts is achieved when the inserts are installed 1/2 to 1 pitch below the surface of the tapped hole. This means that the actual length of an installed insert is equal to dimension Q less 1/2 to 1 pitch. Dimensions S and T allow for tap end clearance of intermediate taps. When using Bottoming and Spiral Flute Taps these dimensions may be reduced by an amount equal to 2 thread pitches. Any countersink depths must be added to these dimensions.

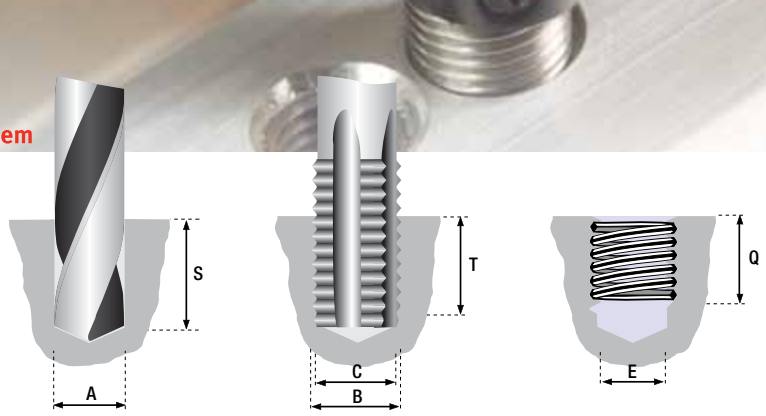

Nominal Thread Size	DRILLED HOLE DIMENSIONS										Nominal Thread Size	TAPPED HOLE DIMENSIONS										E Fitted Minor Dia.
	Drill				S Min. Drilling Depth Inter/Plug Tap							B Major Dia.	C Pitch Diameter				T Minimum Tapping Depth					
	Size		A Minor Dia.		1D	1.5D	2D	2.5D	3D	Min			5H Max	6H Max	1D	1.5D	2D	2.5D	3D			
	mm	inch	mm	mm	mm	mm	mm	mm	mm	mm			mm	mm	mm	mm	mm	mm	mm			
METRIC										METRIC												
M2 X 0.40	2.10	#45	2.087	2.177	3.80	4.80	5.80	6.80	7.80	M2 X 0.40	2.520	2.260	2.296	2.311	3.40	4.40	5.40	6.40	7.40	1.567		
M2.2 X 0.45	2.30	#42	2.297	2.397	4.23	5.33	6.43	7.53	8.63	M2.2 X 0.45	2.785	2.492	2.532	2.547	3.78	4.88	5.98	7.08	8.18	1.713		
M2.5 X 0.45	2.60	#37	2.597	2.697	4.53	5.78	7.03	8.28	9.53	M2.5 X 0.45	3.085	2.792	2.832	2.847	4.08	5.33	6.58	7.83	9.08	2.013		
M3 X 0.50	3.20	1/8	3.108	3.220	5.25	6.75	8.25	9.75	11.25	M3 X 0.50	3.650	3.325	3.367	3.384	4.75	6.25	7.75	9.25	10.75	2.459		
M3.5 X 0.60	3.70	#27	3.630	3.755	6.20	7.95	9.70	11.45	13.20	M3.5 X 0.60	4.279	3.890	3.940	3.959	5.60	7.35	9.10	10.85	12.60	2.850		
M4 X 0.70	4.20	11/64	4.152	4.292	7.15	9.15	11.15	13.15	15.15	M4 X 0.70	4.909	4.455	4.509	4.529	6.45	8.45	10.45	12.45	14.45	3.242		
M5 X 0.80	5.20	13/64	5.173	5.333	8.60	11.10	13.60	16.10	18.60	M5 X 0.80	6.039	5.520	5.577	5.597	7.80	10.30	12.80	15.30	17.80	4.134		
M6 X 1.00	6.30	1/4	6.216	6.406	10.50	13.50	16.50	19.50	22.50	M6 X 1.00	7.299	6.650	6.719	6.742	9.50	12.50	15.50	18.50	21.50	4.917		
M7 X 1.00	7.30	9/32	7.216	7.406	11.50	15.00	18.50	22.00	25.50	M7 X 1.00	8.299	7.650	7.719	7.742	10.50	14.00	17.50	21.00	24.50	5.917		
M8 X 1.25	8.30	21/64	8.271	8.483	13.63	17.63	21.63	25.63	29.63	M8 X 1.25	9.624	8.812	8.886	8.912	12.38	16.38	20.38	24.38	28.38	6.647		
M8 X 1.00	8.30	21/64	8.216	8.406	12.50	16.50	20.50	24.50	28.50	M8 X 1.00	9.299	8.650	8.719	8.742	11.50	15.50	19.50	23.50	27.50	6.917		
M9 X 1.25	9.40	3/8	9.271	9.483	14.63	19.13	23.63	28.13	32.63	M9 X 1.25	10.624	9.812	9.886	9.912	13.38	17.88	22.38	26.88	31.38	7.647		
M9 X 1.00	9.30	23/64	9.216	9.406	13.50	18.00	22.50	27.00	31.50	M9 X 1.00	10.299	9.650	9.719	9.742	12.50	17.00	21.50	26.00	30.50	7.917		
M10 X 1.50	10.40	13/32	10.325	10.561	16.75	21.75	26.75	31.75	36.75	M10 X 1.50	11.949	10.974	11.061	11.089	15.25	20.25	25.25	30.25	35.25	8.376		
M10 X 1.25	10.30	13/32	10.271	10.483	15.63	20.63	25.63	30.63	35.63	M10 X 1.25	11.624	10.812	10.886	10.912	14.38	19.38	24.38	29.38	34.38	8.647		
M10 X 1.00	10.30	13/32	10.216	10.406	14.50	19.50	24.50	29.50	34.50	M10 X 1.00	11.299	10.650	10.724	10.742	13.50	18.50	23.50	28.50	33.50	8.917		
M11 X 1.50	11.40	7/16	11.325	11.561	17.75	23.25	28.75	34.25	39.75	M11 X 1.50	12.949	11.974	12.061	12.089	16.25	21.75	27.25	32.75	38.25	9.376		
M11 X 1.25	11.30	7/16	11.271	11.483	16.63	22.13	27.63	33.13	38.63	M11 X 1.25	12.624	11.812	11.886	11.912	15.38	20.88	26.38	31.88	37.38	9.647		
M11 X 1.00	11.30	7/16	11.216	11.406	15.50	21.00	26.50	32.00	37.50	M11 X 1.00	12.299	11.650	11.724	11.742	14.50	20.00	25.50	31.00	36.50	9.917		
M12 X 1.75	12.50	31/64	12.379	12.644	19.88	25.88	31.88	37.88	43.88	M12 X 1.75	14.273	13.137	13.236	13.271	18.13	24.13	30.13	36.13	42.13	10.106		
M12 X 1.50	12.40	31/64	12.325	12.561	18.75	24.75	30.75	36.75	42.75	M12 X 1.50	13.949	12.974	13.067	13.099	17.25	23.25	29.25	35.25	41.25	10.376		
M12 X 1.25	12.30	31/64	12.271	12.483	17.63	23.63	29.63	35.63	41.63	M12 X 1.25	13.624	12.812	12.886	12.912	16.38	22.38	28.38	34.38	40.38	10.647		
M12 X 1.00	12.30	31/64	12.216	12.406	16.50	22.50	28.50	34.50	40.50	M12 X 1.00	13.299	12.649	12.724	12.749	15.50	21.50	27.50	33.50	39.50	10.917		
M13 X 1.75	13.50	33/64	13.379	13.644	20.88	27.38	33.88	40.38	46.88	M13 X 1.75	15.273	14.137	14.236	14.271	19.13	25.63	32.13	38.63	45.13	11.106		
M13 X 1.50	13.20	33/64	13.325	13.561	19.75	26.25	32.75	39.25	45.75	M13 X 1.50	14.949	13.974	14.067	14.099	18.25	24.75	31.25	37.75	44.25	11.376		
M13 X 1.25	13.20	33/64	13.271	13.483	18.63	25.13	31.63	38.13	44.63	M13 X 1.25	14.624	13.812	13.886	13.912	17.38	23.88	30.38	36.88	43.38	11.647		
M14 X 2.00	14.50	37/64	14.433	14.733	23.00	30.00	37.00	44.00	51.00	M14 X 2.00	16.598	15.299	15.406	15.444	21.00	28.00	35.00	42.00	49.00	11.835		
M14 X 1.50	14.40	9/16	14.325	14.561	20.75	27.75	34.75	41.75	48.75	M14 X 1.50	15.949	14.974	15.067	15.099	19.25	26.25	33.25	40.25	47.25	12.376		
M14 X 1.25	14.30	9/16	14.271	14.483	19.63	26.63	33.63	40.63	47.63	M14 X 1.25	15.624	14.812	14.886	14.912	18.38	25.38	32.38	39.38	46.38	12.674		
M14 X 1.00	14.30	9/16	14.216	14.406	18.50	25.50	32.50	39.50	46.50	M14 X 1.00	15.299	14.649	14.724	14.749	17.50	24.50	31.50	38.50	45.50	12.917		
M15 X 2.00	15.50	39/64	15.433	15.733	24.00	31.50	39.00	46.50	54.00	M15 X 2.00	17.598	16.299	16.406	16.444	22.00	29.50	37.00	44.50	52.00	12.835		
M15 X 1.50	15.30	39/64	15.325	15.561	21.75	29.25	36.75	44.25	51.75	M15 X 1.50	16.949	15.974	16.067	16.099	20.25	27.75	35.25	42.75	50.25	13.376		
M16 X 2.00	16.50	21/32	16.433	16.733	25.00	33.00	41.00	49.00	57.00	M16 X 2.00	18.598	17.299	17.406	17.444	23.00	31.00	39.00	47.00	55.00	13.835		
M16 X 1.50	16.50	21/32	16.325	16.561	22.75	30.75	38.75	46.75	54.75	M16 X 1.50	17.949	16.974	17.067	17.099	21.25	29.25	37.25	45.25	53.25	14.376		
M18 X 2.50	18.80	47/64	18.541	18.896	29.25	38.25	47.25	56.25	65.25	M18 X 2.50	21.248	19.624	19.738	19.778	26.75	35.75	44.75	53.75	62.75	15.294		
M18 X 2.00	18.50	23/32	18.433	18.733	27.00	36.00	45.00	54.00	63.00	M18 X 2.00	20.598	19.299	19.406	19.444	25.00	34.00	43.00	52.00	61.00	15.835		
M18 X 1.50	18.50	23/32	18.325	18.561	24.75	33.75	42.75	51.75	60.75	M18 X 1.50	19.949	18.974	19.067	19.099	23.25	32.25	41.25	50.25	59.25	16.376		
M20 X 2.50	20.80	13/16	20.541	20.896	31.25	41.25	51.25	61.25	71.25	M20 X 2.50	23.248	21.624	21.738	21.778	28.75	38.75	48.75	58.75	68.75	17.294		
M20 X 2.00	20.50	13/16	20.433	20.733	29.00	39.00	49.00	59.00	69.00	M20 X 2.00	22.598	21.299	21.406	21.444	27.00	37.00	47.00	57.00	67.00	17.835		
M20 X 1.50	20.50	13/16	20.325	20.561	26.75	36.75	46.75	56.75	66.75	M20 X 1.50	21.949	20.974	21.067	21.099	25.25	35.25	45.25	55.25	65.25	18.376		
M22 X 2.50	22.80	57/64	22.541	22.896	33.25	44.25	55.25	66.25	77.25	M22 X 2.50	25.248	23.624	23.738	23.778	30.75	41.75	52.75	63.75	74.75	19.294		
M22 X 2.00	22.50	57/64	22.433	22.733	31.00	42.00	53.00	64.00	75.00	M22 X 2.00	24.598	23.299	23.406	23.444	29.00	40.00	51.00	62.00	73.00	19.835		
M22 X 1.50	22.50	57/64	22.325	22.561	28.75	39.75	50.75	61.75	72.75	M22 X 1.50	23.949	22.974	23.067	23.099	27.25	38.25	49.25	60.25	71.25	20.376		
M24 X 3.00	25.00	31/32	24.650	25.050	37.50	49.50	61.50	73.50	85.50	M24 X 3.00	27.897	25.948	26.093	26.135	34.50	46.50	58.50	70.50	82.50	20.752		
M24 X 2.00	24.50	31/32	24.433	24.733	33.00	45.00	57.00	69.00	81.00	M24 X 2.00	26.598	25.299	25.414	25.454	31.00	43.00	55.00	67.00	79.00	21.835		
M24 X 1.50	24.50	31/32	24.325	24.561	30.75	42.75	54.75	66.75	78.75	M24 X 1.50	25.949	24.974	25.044	25.135	29.25	41.25	53.25	65.25	77.25	22.376		
M26 X 1.50	26.50	1 1/32	26.325	26.561	32.75	45.75	58.75	71.75	84.75	M26 X 1.50	27.949	26.975	27.044	27.135	31.25	44.25	57.25	70.25	83.25	24.376		
M27 X 3.00	28.00	1.3/32	27.650	28.050	40.50	54.00	67.50	81.00	94.50	M27 X 3.00	30.897	28.498	29.093	29.135	37.50	51.00	64.50	78.00	91.50	23.752		
M27 X 2.00	27.50	1.5/64	27.433	27.733	36.00</																	

IMPORTANT The success of any drilling and tapping operation is dependant upon many factors –type of material being cut, cutting speed, coolant, equipment being used – and it is not possible to give specific drill sizes for each material. Drill sizes shown are recommendations only and PowerCoil would strongly suggest that independent testing be performed for specific and critical applications.

When using wire thread inserts it is important that the drilling and tapping diameters and lengths listed below are adhered to.

The figures outlined in these tables encompass effective free coil tolerances for most globally recognized standards and manufacturers, including those of reduced diameter wire thread inserts.

PowerCoil wire thread inserts can be manufactured to different standards upon request. Technical data on these standards can be obtained from our website – www.powercoil.com.au.

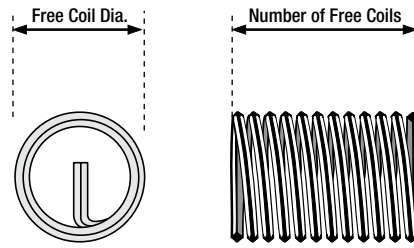

Nominal Thread Size	INSERT SPECIFICATIONS																Nominal Thread Size	
	Q Nominal Length – installed					Free Coil Diameter		Number of Free Coils ± 1/4 coil counted 90° from Tang										
	1D	1.5D	2D	2.5D	3D	Min	Max	1D		1.5D		2D		2.5D		3D		
	mm	mm	mm	mm	mm	mm	mm	Min	Max	Min	Max	Min	Max	Min	Max	Min		Max
METRIC																	METRIC	
M2 X 0.40	2.00	3.00	4.00	5.00	6.00	2.49	2.70	3.00	3.30	5.20	5.70	7.40	8.10	9.60	10.50	11.80	13.00	M2 X 0.40
M2.2 X 0.45	2.20	3.30	4.40	5.50	6.60	2.76	3.00	2.90	3.20	5.00	5.50	7.10	7.90	9.30	10.30	11.40	12.60	M2.2 X 0.45
M2.5 X 0.45	2.50	3.75	5.00	6.25	7.50	3.05	3.70	3.10	3.80	5.20	6.50	7.40	9.20	9.50	11.90	11.70	14.60	M2.5 X 0.45
M3 X 0.50	3.00	4.50	6.00	7.50	9.00	3.61	4.35	3.40	4.30	5.80	7.20	8.20	10.10	10.50	13.10	12.90	16.00	M3 X 0.50
M3.5 X 0.60	3.50	5.25	7.00	8.75	10.50	4.24	4.95	3.40	4.10	5.80	7.00	8.20	9.80	10.50	12.60	12.90	15.50	M3.5 X 0.60
M4 x 0.70	4.00	6.00	8.00	10.00	12.00	4.86	5.60	3.40	4.00	5.70	6.80	8.10	9.60	10.50	12.30	12.80	15.10	M4 x 0.70
M5 X 0.80	5.00	7.50	10.00	12.50	15.00	5.98	6.80	3.90	4.50	6.50	7.60	9.20	10.60	11.80	13.70	14.40	16.70	M5 X 0.80
M6 X 1.00	6.00	9.00	12.00	15.00	18.00	7.23	7.95	3.80	4.30	6.40	7.20	9.10	10.10	11.70	13.10	14.30	16.00	M6 X 1.00
M7 X 1.00	7.00	10.50	14.00	17.50	21.00	8.22	9.20	4.60	5.30	7.70	8.70	10.70	12.10	13.70	15.60	16.70	19.00	M7 X 1.00
M8 X 1.25	8.00	12.00	16.00	20.00	24.00	9.53	10.35	4.20	4.70	7.10	7.80	9.90	10.90	12.80	14.10	15.60	17.20	M8 X 1.25
M8 X 1.00	8.00	12.00	16.00	20.00	24.00	9.39	10.25	5.60	6.10	9.10	10.00	12.50	13.80	16.00	17.70	19.50	21.50	M8 X 1.00
M9 X 1.25	9.00	13.50	18.00	22.50	27.00	10.52	11.16	5.10	5.50	8.40	9.00	11.70	12.50	15.00	16.10	18.30	19.60	M9 X 1.25
M9 x 1.00	9.00	13.50	18.00	22.50	27.00	10.40	11.23	6.50	7.10	10.50	11.50	14.50	15.80	18.50	20.20	22.50	24.50	M9 x 1.00
M10 X 1.50	10.00	15.00	20.00	25.00	30.00	11.83	12.50	4.60	4.90	7.70	8.20	10.80	11.50	13.80	14.70	16.90	18.00	M10 X 1.50
M10 X 1.25	10.00	15.00	20.00	25.00	30.00	11.74	12.65	5.60	6.10	9.20	10.00	12.70	13.80	16.30	17.70	19.80	21.50	M10 X 1.25
M10 x 1.00	10.00	15.00	20.00	25.00	30.00	11.41	12.50	7.30	8.10	11.70	12.90	16.10	17.80	20.50	22.60	24.90	27.50	M10 x 1.00
M11 X 1.50	11.00	16.50	22.00	27.50	33.00	12.82	13.59	5.20	5.60	8.60	9.20	12.00	12.80	15.40	16.40	18.70	20.00	M11 X 1.50
M11 X 1.25	11.00	16.50	22.00	27.50	33.00	12.75	13.76	6.40	6.90	10.30	11.20	14.20	15.40	18.10	19.70	22.00	23.90	M11 X 1.25
M11 X 1.00	11.00	16.50	22.00	27.50	33.00	12.42	13.41	8.40	9.10	13.30	14.40	18.20	19.80	23.10	25.10	28.00	30.40	M11 X 1.00
M12 X 1.75	12.00	18.00	24.00	30.00	36.00	14.13	15.00	4.80	5.10	7.90	8.50	11.10	11.90	14.20	15.20	17.30	18.60	M12 X 1.75
M12 X 1.50	12.00	18.00	24.00	30.00	36.00	14.09	15.20	5.60	6.10	9.20	10.00	12.70	13.80	16.20	17.70	19.80	21.50	M12 X 1.50
M12 X 1.25	12.00	18.00	24.00	30.00	36.00	13.76	15.00	7.00	7.70	11.20	12.40	15.50	17.00	19.70	21.60	23.90	26.30	M12 X 1.25
M12 X 1.00	12.00	18.00	24.00	30.00	36.00	13.43	14.49	9.30	10.10	14.70	15.90	20.00	21.70	25.40	27.60	30.80	33.40	M12 X 1.00
M13 X 1.75	13.00	19.50	26.00	32.50	39.00	15.12	16.04	5.30	5.70	8.70	9.40	12.20	13.00	15.60	16.70	19.00	20.30	M13 X 1.75
M13 X 1.50	13.00	19.50	26.00	32.50	39.00	15.10	16.29	6.20	6.80	10.10	11.00	13.90	15.20	17.80	19.30	21.60	23.50	M13 X 1.50
M13 X 1.25	13.00	19.50	26.00	32.50	39.00	14.77	15.94	7.80	8.50	12.50	13.50	17.10	18.60	21.70	23.60	26.40	28.70	M13 X 1.25
M14 X 2.00	14.00	21.00	28.00	35.00	42.00	16.43	17.35	5.00	5.30	8.20	8.70	11.40	12.10	14.60	15.60	17.90	19.00	M14 X 2.00
M14 X 1.50	14.00	21.00	28.00	35.00	42.00	16.11	17.25	6.90	7.50	11.10	12.00	15.30	16.50	19.40	21.00	23.60	25.50	M14 X 1.50
M14 X 1.25	14.00	21.00	28.00	35.00	42.00	15.78	17.03	8.60	9.30	13.60	14.70	18.60	20.20	23.60	25.60	28.60	31.00	M14 X 1.25
M14 X 1.00	14.00	21.00	28.00	35.00	42.00	15.45	16.68	11.10	12.10	17.40	18.90	23.70	25.70	30.00	32.50	36.20	39.30	M14 X 1.00
M15 X 2.00	15.00	22.50	30.00	37.50	45.00	17.42	18.48	5.40	5.80	8.80	9.50	12.30	13.10	15.70	16.80	19.20	20.50	M15 X 2.00
M15 X 1.50	15.00	22.50	30.00	37.50	45.00	17.12	18.47	7.50	8.10	11.90	12.90	16.40	17.80	20.80	22.60	25.30	27.50	M15 X 1.50
M16 X 2.00	16.00	24.00	32.00	40.00	48.00	18.41	19.60	5.90	6.30	9.50	10.20	13.20	14.20	16.90	18.10	20.50	22.00	M16 X 2.00
M16 X 1.50	16.00	24.00	32.00	40.00	48.00	18.13	19.60	8.00	8.80	12.80	13.90	17.50	19.10	22.30	24.30	27.00	29.40	M16 X 1.50
M18 X 2.50	18.00	27.00	36.00	45.00	54.00	21.04	22.00	5.20	5.50	8.60	9.00	11.90	12.50	15.30	16.10	18.60	19.60	M18 X 2.50
M18 X 2.00	18.00	27.00	36.00	45.00	54.00	20.80	21.85	6.70	7.10	10.90	11.50	15.00	15.80	19.10	20.20	23.20	24.50	M18 X 2.00
M18 X 1.50	18.00	27.00	36.00	45.00	54.00	20.15	21.75	9.30	10.10	14.60	15.90	20.00	21.70	25.40	27.60	30.70	33.40	M18 X 1.50
M20 X 2.50	20.00	30.00	40.00	50.00	60.00	23.02	24.40	5.90	6.30	9.60	10.20	13.30	14.20	16.90	18.10	20.60	22.00	M20 X 2.50
M20 X 2.00	20.00	30.00	40.00	50.00	60.00	22.82	24.05	7.70	8.10	12.20	12.90	16.80	17.80	21.40	22.60	25.90	27.50	M20 X 2.00
M20 X 1.50	20.00	30.00	40.00	50.00	60.00	22.17	24.00	10.50	11.40	16.40	17.90	22.40	24.40	28.30	30.90	34.30	37.40	M20 X 1.50
M22 X 2.50	22.00	33.00	44.00	55.00	66.00	25.00	26.90	6.50	7.10	10.50	11.40	14.50	15.80	18.50	20.10	22.50	24.50	M22 X 2.50
M22 X 2.00	22.00	33.00	44.00	55.00	66.00	24.84	26.50	8.50	9.10	13.40	14.40	18.40	19.80	23.40	25.10	28.40	30.40	M22 X 2.00
M22 X 1.50	22.00	33.00	44.00	55.00	66.00	24.19	26.45	11.60	12.70	18.10	19.90	24.60	27.00	31.10	34.20	37.60	41.30	M22 X 1.50
M24 X 3.00	24.00	36.00	48.00	60.00	72.00	27.62	29.00	5.90	6.30	9.70	10.20	13.40	14.20	17.10	18.10	20.90	22.00	M24 X 3.00
M24 X 2.00	24.00	36.00	48.00	60.00	72.00	26.86	29.10	9.20	10.10	14.60	15.90	19.90	21.70	25.30	27.60	30.60	33.40	M24 X 2.00
M24 X 1.50	24.00	36.00	48.00	60.00	72.00	26.21	28.28	12.90	14.00	20.10	21.80	27.30	29.70	34.50	37.50	41.70	45.30	M24 X 1.50
M26 X 1.50	26.00	39.00	52.00	65.00	78.00	28.23	30.46	14.20	15.40	22.00	23.80	29.80	32.30	37.60	40.80	45.40	49.20	M26 X 1.50
M27 X 3.00	27.00	40.50	54.00	67.50	81.00	30.59	32.40	6.80	7.30	11.00	11.70	15.20	16.20	19.30	20.60	23.50	25.10	M27 X 3.00
M27 X 2.00	27.00	40.50	54.00	67.50	81.00	29.89	32.30	10.60	11.60	16.70	18.10	22.70	24.70	28.80	31.30	34.80	37.90	M27 X 2.00
M30 X 3.50	30.00	45.00	60.00	75.00	90.00	34.20	35.81	6.50	6.90	10.50	11.10	14.50	15.30	18.60	19.50	22.60	23.80	M30 X 3.50
M30 X 3.00	30.00	45.00	60.00	75.00	90.00	34.24	36.10	7.60	8.10	12.20	12.90	16.80	17.80	21.30	22.60	25.90	27.50	M30 X 3.00
M30 X 2.00	30.00	45.00	60.00	75.00	90.00	32.92	35.70	12.00	13.00	18.70	20.40	25.40	27.70	32.10	35.00	38.80	42.30	M30 X 2.00
M33 X 3.50	33.00	49.50	66.00	82.50	99.00	37.17	38.80	7.40	7.70	11.80	12.40	16.20	17.00	20.70	21.70	25.10	26.40	M33 X 3.50
M33 X 3.00	33.00	49.50	66.00	82.50	99.00	37.27	39.50	8.50	9.10	13.50	14.40	18.50	19.80	23.60	25.10	28.60	30.40	M33 X 3.00
M33 X 2.00	33.00	49.50	66.00	82.50	99.00	35.95	39.20	13.30	14.50	20.60	22.60	28.00	30.60	35.30	38.70	42.70	46.80	M33 X 2.00
M36 X 4.00	36.00	54.00	72.00	90.00	108.00	40.78	42.67	6.90	7.30	11.20	11.70	15.40	16.20	19.60	20.60	23.80	25.10	M36 X 4.00
M36 X 3.00	36.00	54.00	72.00	90.00	108.00	40.30	42.70	9.50	10.10	14.90	15.90	20.40	21.70					

Optimum thread performance with Wire Thread Inserts is achieved when the inserts are installed 1/2 to 1 pitch below the surface of the tapped hole. This means that the actual length of an installed insert is equal to dimension Q less 1/2 to 1 pitch. Dimensions S and T allow for tap end clearance of intermediate taps. When using Bottoming and Spiral Flute Taps these dimensions may be reduced by an amount equal to 2 thread pitches. Any countersink depths must be added to these dimensions.

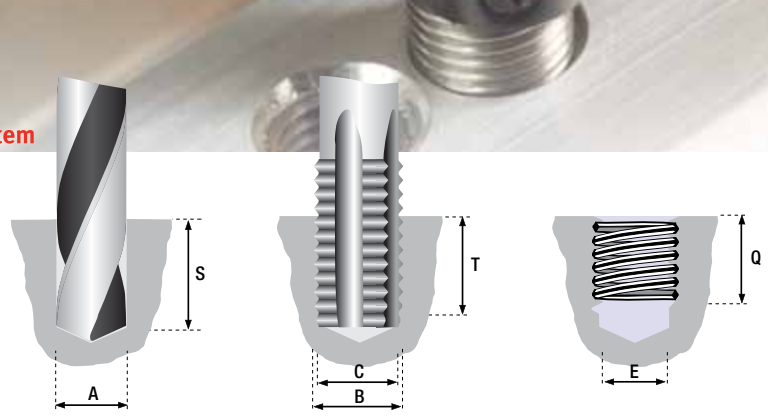

Nominal Thread Size	DRILLED HOLE DIMENSIONS									Nominal Thread Size	TAPPED HOLE DIMENSIONS									E Fitted Minor Dia.
	Drill				S Min. Drilling Depth Inter/Plug Tap						B Major Dia.	C Pitch Diameter			T Minimum Tapping Depth					
	Size	A Minor Dia.	1D	1.5D	2D	2.5D	3D	Min	2B Max			1B Max	1D	1.5D	2D	2.5D	3D			
mm	inch	inch	inch	inch	inch	inch	inch	inch	inch	inch	inch	inch	inch	inch	inch					
UNC										UNC										
2 X 56	2.40	#41	0.090	0.094	0.166	0.209	0.252	0.295	0.338	2 X 56	0.109	0.098	0.099	0.100	0.148	0.191	0.234	0.277	0.320	0.0667
3 X 48	2.70	#36	0.104	0.108	0.193	0.242	0.292	0.341	0.391	3 X 48	0.126	0.113	0.114	0.115	0.172	0.221	0.271	0.320	0.370	0.0764
4 X 40	3.00	#31	0.117	0.122	0.224	0.280	0.336	0.392	0.448	4 X 40	0.145	0.128	0.130	0.131	0.199	0.255	0.311	0.367	0.423	0.0849
5 X 40	3.40	#29	0.130	0.135	0.237	0.300	0.362	0.425	0.487	5 X 40	0.158	0.141	0.143	0.144	0.212	0.275	0.337	0.400	0.462	0.0979
6 X 32	3.70	#25	0.145	0.150	0.279	0.348	0.417	0.486	0.555	6 X 32	0.179	0.158	0.160	0.161	0.247	0.316	0.385	0.454	0.523	0.1040
8 X 32	4.40	11/64	0.171	0.176	0.305	0.387	0.469	0.551	0.633	8 X 32	0.205	0.184	0.186	0.187	0.273	0.355	0.437	0.519	0.601	0.1300
10 X 24	5.10	13/64	0.199	0.205	0.377	0.472	0.567	0.662	0.757	10 X 24	0.244	0.217	0.219	0.220	0.336	0.431	0.526	0.621	0.716	0.1450
12 X 24	5.70	15/64	0.225	0.231	0.403	0.511	0.619	0.727	0.835	12 X 24	0.270	0.243	0.245	0.247	0.362	0.470	0.578	0.686	0.794	0.1710
1/4 X 20	6.70	17/64	0.261	0.270	0.475	0.600	0.725	0.850	0.975	1/4 X 20	0.315	0.283	0.285	0.286	0.425	0.550	0.675	0.800	0.925	0.1959
5/16 X 18	8.30	21/64	0.325	0.334	0.562	0.718	0.875	1.031	1.187	5/16 X 18	0.385	0.349	0.352	0.353	0.507	0.663	0.819	0.975	1.132	0.2524
3/8 X 16	9.90	25/64	0.389	0.399	0.656	0.844	1.031	1.219	1.406	3/8 X 16	0.456	0.416	0.419	0.420	0.594	0.781	0.969	1.156	1.344	0.3073
7/16 X 14	11.60	29/64	0.453	0.464	0.758	0.977	1.196	1.415	1.633	7/16 X 14	0.530	0.484	0.488	0.489	0.687	0.906	1.125	1.344	1.562	0.3602
1/2 X 13	13.00	33/64	0.517	0.528	0.846	1.096	1.346	1.596	1.846	1/2 X 13	0.600	0.550	0.554	0.555	0.769	1.019	1.269	1.519	1.769	0.4167
9/16 X 12	15.00	19/32	0.581	0.592	0.937	1.219	1.500	1.781	2.062	9/16 X 12	0.671	0.617	0.621	0.623	0.854	1.135	1.417	1.698	1.979	0.4723
5/8 X 11	16.50	21/32	0.645	0.657	1.034	1.347	1.659	1.972	2.284	5/8 X 11	0.743	0.684	0.689	0.690	0.943	1.256	1.568	1.881	2.193	0.5266
3/4 X 10	19.80	25/32	0.772	0.784	1.200	1.575	1.950	2.325	2.700	3/4 X 10	0.880	0.815	0.820	0.822	1.100	1.475	1.850	2.225	2.600	0.6417
7/8 X 9	23.00	29/32	0.899	0.912	1.375	1.812	2.250	2.687	3.125	7/8 X 9	1.019	0.947	0.952	0.954	1.264	1.701	2.139	2.576	3.014	0.7547
1 X 8	26.20	1.1/32	1.027	1.042	1.562	2.062	2.562	3.062	3.562	1 X 8	1.162	1.081	1.087	1.089	1.437	1.937	2.437	2.937	3.437	0.8647
1-1/8 X 7	29.50	1.5/32	1.156	1.171	1.768	2.330	2.893	3.455	4.018	1-1/8 X 7	1.311	1.218	1.224	1.226	1.625	2.187	2.750	3.312	3.875	0.9704
1-1/4 X 7	32.50	1.9/32	1.281	1.296	1.893	2.518	3.143	3.768	4.393	1-1/4 X 7	1.436	1.343	1.349	1.351	1.750	2.375	3.000	3.625	4.250	1.0954
1-3/8 X 6	36.00	1.13/32	1.411	1.431	2.125	2.812	3.500	4.187	4.875	1-3/8 X 6	1.591	1.483	1.490	1.493	1.958	2.646	3.333	4.021	4.708	1.1946
1-1/2 X 6	39.50	1.35/64	1.536	1.556	2.250	3.000	3.750	4.500	5.250	1-1/2 X 6	1.716	1.608	1.615	1.618	2.083	2.833	3.583	4.333	5.083	1.3196
UNF										UNF										
2 X 64	2.30	3/32	0.089	0.093	0.156	0.199	0.242	0.285	0.328	2 X 64	0.106	0.096	0.097	0.098	0.141	0.184	0.227	0.270	0.313	0.0691
3 X 56	2.70	#37	0.103	0.107	0.179	0.229	0.278	0.328	0.377	3 X 56	0.122	0.111	0.112	0.113	0.161	0.210	0.260	0.310	0.359	0.0797
4 X 48	3.00	#31	0.117	0.121	0.206	0.262	0.318	0.374	0.430	4 X 48	0.139	0.126	0.127	0.128	0.185	0.241	0.297	0.353	0.409	0.0894
5 X 44	3.40	#30	0.130	0.134	0.227	0.290	0.352	0.414	0.477	5 X 44	0.155	0.140	0.141	0.142	0.204	0.267	0.329	0.391	0.454	0.1004
6 X 40	3.70	#26	0.143	0.148	0.250	0.319	0.388	0.457	0.526	6 X 40	0.171	0.154	0.156	0.157	0.225	0.294	0.363	0.432	0.501	0.1111
8 X 36	4.40	11/64	0.170	0.175	0.289	0.371	0.453	0.535	0.617	8 X 36	0.200	0.182	0.184	0.185	0.261	0.343	0.425	0.507	0.589	0.134
10 X 32	5.10	13/64	0.197	0.202	0.331	0.426	0.521	0.616	0.711	10 X 32	0.231	0.210	0.212	0.213	0.299	0.394	0.489	0.584	0.679	0.156
1/4 X 28	6.60	17/64	0.258	0.265	0.411	0.536	0.661	0.786	0.911	1/4 X 28	0.296	0.273	0.275	0.277	0.375	0.500	0.625	0.750	0.875	0.2113
5/16 X 24	8.20	21/64	0.322	0.329	0.500	0.656	0.812	0.969	1.125	5/16 X 24	0.367	0.340	0.342	0.343	0.458	0.614	0.771	0.927	1.083	0.2674
3/8 X 24	9.80	25/64	0.384	0.391	0.562	0.750	0.937	1.124	1.312	3/8 X 24	0.429	0.402	0.405	0.406	0.521	0.708	0.896	1.083	1.271	0.3299
7/16 X 20	11.50	29/64	0.448	0.456	0.662	0.881	1.100	1.319	1.537	7/16 X 20	0.503	0.470	0.473	0.474	0.612	0.831	1.050	1.269	1.487	0.3834
1/2 X 20	13.00	33/64	0.511	0.518	0.725	0.975	1.225	1.475	1.725	1/2 X 20	0.565	0.533	0.536	0.537	0.675	0.925	1.175	1.425	1.675	0.4459
9/16 X 18	14.70	37/64	0.575	0.582	0.811	1.093	1.374	1.655	1.936	9/16 X 18	0.635	0.599	0.602	0.604	0.756	1.038	1.319	1.600	1.881	0.5024
5/8 X 18	16.30	41/64	0.637	0.645	0.874	1.187	1.500	1.812	2.124	5/8 X 18	0.697	0.661	0.665	0.666	0.819	1.132	1.444	1.757	2.069	0.5649
3/4 X 16	19.50	49/64	0.764	0.772	1.031	1.406	1.781	2.156	2.531	3/4 X 16	0.831	0.791	0.795	0.796	0.969	1.344	1.719	2.094	2.469	0.6823
7/8 X 14	22.50	57/64	0.891	0.899	1.196	1.634	2.071	2.509	2.946	7/8 X 14	0.968	0.921	0.926	0.927	1.125	1.562	2.000	2.437	2.875	0.7977
1 X 12	26.00	1.1/64	1.018	1.028	1.375	1.875	2.375	2.875	3.375	1 X 12	1.108	1.054	1.059	1.061	1.292	1.792	2.292	2.792	3.292	0.9098
1 X 14	26.00	1.1/64	1.016	1.024	1.320	1.820	2.320	2.820	3.320	1 X 14	1.093	1.046	1.051	1.053	1.250	1.750	2.250	2.750	3.250	0.9277
1-1/8 X 12	29.50	1.5/32	1.143	1.154	1.500	2.062	2.625	3.187	3.750	1-1/8 X 12	1.233	1.179	1.184	1.186	1.417	1.979	2.542	3.104	3.667	1.0348
1-1/4 X 12	32.50	1.9/32	1.268	1.279	1.625	2.250	2.875	3.500	4.125	1-1/4 X 12	1.358	1.304	1.309	1.311	1.542	2.167	2.792	3.417	4.042	1.1598
1-3/8 X 12	35.50	1.13/32	1.393	1.404	1.750	2.438	3.125	3.813	4.500	1-3/8 X 12	1.483	1.429	1.434	1.436	1.667	2.354	3.042	3.729	4.417	1.2848
1-1/2 X 12	38.50	1.17/32	1.518	1.529	1.875	2.625	3.375	4.125	4.875	1-1/2 X 12	1.608	1.554	1.560	1.562	1.792	2.542	3.292	4.042	4.792	1.4098
1-1/2 X 6	39.50	1.35/64	1.536	1.556	2.250	3.000	3.750	4.500	5.250	1-1/2 X 6	1.716	1.608	1.615	1.618	2.083	2.833	3.583	4.333	5.083	1.3196

IMPORTANT The success of any drilling and tapping operation is dependant upon many factors – type of material being cut, cutting speed, coolant, equipment being used – and it is not possible to give specific drill sizes for each material. Drill sizes shown are recommendations only and PowerCoil would strongly suggest that independent testing be performed for specific and critical applications.

When using wire thread inserts it is important that the drilling and tapping diameters and lengths listed below are adhered to.

The figures outlined in these tables encompass effective free coil tolerances for most globally recognized standards and manufacturers, including those of reduced diameter wire thread inserts. PowerCoil wire thread inserts can be manufactured to different standards upon request. Technical data on these standards can be obtained from our website – www.powercoil.com.au.

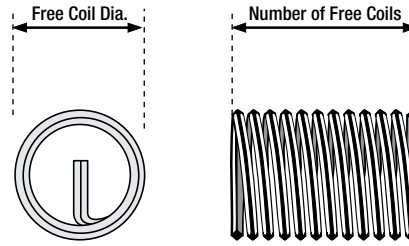

Nominal Thread Size	INSERT SPECIFICATIONS																Nominal Thread Size	
	Q Nominal Length – installed					Free Coil Diameter		Number of Free Coils ± 1/4 coil counted 90° from Tang										
	1D	1.5D	2D	2.5D	3D	Min	Max	1D		1.5D		2D		2.5D		3D		
	inch	inch	inch	inch	inch	inch	inch	Min	Max	Min	Max	Min	Max	Min	Max	Min		Max
UNC																	UNC	
2 X 56	0.086	0.129	0.172	0.215	0.258	0.11	0.12	2.80	3.10	4.80	5.40	6.90	7.80	9.00	10.10	11.10	12.50	2 X 56
3 X 48	0.099	0.148	0.198	0.247	0.297	0.12	0.14	2.80	3.20	4.90	5.50	7.00	7.90	9.00	10.30	11.20	12.70	3 X 48
4 X 40	0.112	0.168	0.224	0.280	0.336	0.14	0.16	2.40	2.80	4.30	4.90	6.20	7.10	8.10	9.20	10.00	11.40	4 X 40
5 X 40	0.125	0.187	0.250	0.312	0.375	0.16	0.17	2.90	3.30	5.00	5.70	7.20	8.10	9.30	10.50	11.50	13.00	5 X 40
6 X 32	0.138	0.207	0.276	0.345	0.414	0.18	0.19	2.40	2.70	4.30	4.80	6.20	7.00	8.20	9.10	10.10	11.20	6 X 32
8 X 32	0.164	0.246	0.328	0.410	0.492	0.20	0.22	3.20	3.50	5.50	6.10	7.80	8.60	10.10	11.20	12.40	13.70	8 X 32
10 X 24	0.190	0.285	0.380	0.475	0.570	0.24	0.26	2.60	2.80	4.60	5.00	6.70	7.20	8.70	9.40	10.70	11.60	10 X 24
12 X 24	0.216	0.324	0.432	0.540	0.648	0.27	0.28	3.20	3.50	5.60	6.00	7.90	8.50	10.30	11.00	12.60	13.50	12 X 24
1/4 X 20	0.250	0.375	0.500	0.625	0.750	0.31	0.33	3.10	3.30	5.30	5.70	7.60	8.10	9.90	10.50	12.10	13.00	1/4 X 20
5/16 X 18	0.312	0.469	0.625	0.781	0.937	0.38	0.40	3.70	3.90	6.30	6.70	8.90	9.50	11.50	12.20	14.10	15.00	5/16 X 18
3/8 X 16	0.375	0.562	0.750	0.937	1.125	0.45	0.47	4.10	4.30	6.80	7.20	9.60	10.10	12.40	13.10	15.20	16.00	3/8 X 16
7/16 X 14	0.437	0.656	0.875	1.094	1.312	0.52	0.55	4.10	4.40	7.00	7.40	9.80	10.40	12.60	13.40	15.50	16.30	7/16 X 14
1/2 X 13	0.500	0.750	1.000	1.250	1.500	0.59	0.62	4.50	4.80	7.50	8.00	10.60	11.10	13.60	14.30	16.60	17.50	1/2 X 13
9/16 X 12	0.562	0.844	1.125	1.406	1.687	0.66	0.69	4.80	5.00	7.90	8.40	11.10	11.70	14.20	15.00	17.40	18.30	9/16 X 12
5/8 X 11	0.625	0.937	1.250	1.562	1.875	0.74	0.77	4.90	5.10	8.10	8.50	11.30	11.90	14.50	15.20	17.70	18.60	5/8 X 11
3/4 X 10	0.750	1.125	1.500	1.875	2.250	0.87	0.91	5.50	5.80	9.00	9.50	12.60	13.10	16.10	16.80	19.60	20.50	3/4 X 10
7/8 X 9	0.875	1.312	1.750	2.187	2.625	1.01	1.05	5.90	6.20	9.60	10.00	13.30	13.90	17.00	17.80	20.70	21.70	7/8 X 9
1 X 8	1.000	1.500	2.000	2.500	3.000	1.15	1.20	6.00	6.30	9.80	10.20	13.60	14.20	17.30	18.10	21.10	22.00	1 X 8
1-1/8 X 7	1.125	1.687	2.250	2.812	3.375	1.30	1.36	5.90	6.20	9.60	10.10	13.30	14.00	17.00	17.90	20.70	21.80	1-1/8 X 7
1-1/4 X 7	1.250	1.875	2.500	3.125	3.750	1.42	1.48	6.70	7.10	10.90	11.40	15.00	15.80	19.20	20.10	23.30	24.40	1-1/4 X 7
1-3/8 X 6	1.375	2.062	2.750	3.437	4.125	1.58	1.64	6.20	6.50	10.10	10.60	14.00	14.60	17.80	18.70	21.70	22.70	1-3/8 X 6
1-1/2 X 6	1.500	2.250	3.000	3.750	4.500	1.70	1.77	6.90	7.30	11.20	11.70	15.40	16.10	19.60	20.60	23.90	25.00	1-1/2 X 6
UNF																	UNF	
2 X 64	0.086	0.129	0.172	0.215	0.258	0.11	0.12	3.40	3.70	5.80	6.30	8.20	8.90	10.50	11.60	12.90	14.20	2 X 64
3 X 56	0.099	0.148	0.198	0.247	0.297	0.12	0.15	3.10	3.70	5.20	6.40	7.40	9.00	9.60	11.60	11.80	14.30	3 X 56
4 X 48	0.112	0.168	0.224	0.280	0.336	0.14	0.16	3.20	3.70	5.40	6.40	7.60	9.00	9.80	11.60	12.10	14.20	4 X 48
5 X 44	0.125	0.187	0.250	0.312	0.375	0.16	0.17	3.40	3.70	5.80	6.30	8.20	8.90	10.60	11.50	13.00	14.20	5 X 44
6 X 40	0.138	0.207	0.276	0.345	0.414	0.17	0.19	3.20	3.70	5.50	6.30	7.80	9.00	10.10	11.60	12.40	14.20	6 X 40
8 X 36	0.164	0.246	0.328	0.410	0.492	0.20	0.22	3.60	4.10	6.10	6.90	8.60	9.70	11.10	12.50	13.60	15.30	8 X 36
10 X 32	0.190	0.285	0.380	0.475	0.570	0.23	0.26	3.80	4.30	6.40	7.20	9.00	10.10	11.60	13.00	14.20	15.90	10 X 32
1/4 X 28	0.250	0.375	0.500	0.625	0.750	0.30	0.33	4.70	5.20	7.70	8.50	10.80	11.90	13.80	15.20	16.90	18.60	1/4 X 28
5/16 X 24	0.312	0.469	0.625	0.781	0.937	0.37	0.40	5.10	5.60	8.50	9.20	11.70	12.80	15.00	16.40	18.30	20.00	5/16 X 24
3/8 X 24	0.375	0.562	0.750	0.937	1.125	0.43	0.47	6.50	7.10	10.50	11.40	14.50	15.80	18.50	20.10	22.50	24.50	3/8 X 24
7/16 X 20	0.437	0.656	0.875	1.094	1.312	0.51	0.55	6.30	6.90	10.20	11.10	14.00	15.30	17.90	19.50	21.70	23.70	7/16 X 20
1/2 X 20	0.500	0.750	1.000	1.250	1.500	0.57	0.62	7.40	8.10	11.90	12.90	16.30	17.80	20.80	22.60	25.20	27.50	1/2 X 20
9/16 X 18	0.562	0.844	1.125	1.406	1.687	0.64	0.69	7.60	8.30	12.20	13.30	16.80	18.20	21.30	23.10	25.90	28.10	9/16 X 18
5/8 X 18	0.625	0.937	1.250	1.562	1.875	0.70	0.76	8.70	9.40	13.80	14.90	18.90	20.50	24.00	26.00	29.10	31.50	5/8 X 18
3/4 X 16	0.750	1.125	1.500	1.875	2.250	0.84	0.90	9.30	10.10	14.70	15.90	20.10	21.70	25.50	27.60	30.90	33.40	3/4 X 16
7/8 X 14	0.875	1.312	1.750	2.187	2.625	0.98	1.05	9.60	10.30	15.10	16.30	20.60	22.20	26.10	28.20	31.60	34.20	7/8 X 14
1 X 12	1.000	1.500	2.000	2.500	3.000	1.12	1.20	9.40	10.10	14.80	16.00	20.30	21.80	25.70	27.70	31.10	33.50	1 X 12
1 X 14	1.000	1.500	2.000	2.500	3.000	1.10	1.19	11.20	12.10	17.50	18.90	23.80	25.70	30.10	32.50	36.40	39.40	1 X 14
1-1/8 X 12	1.125	1.687	2.250	2.812	3.375	1.25	1.33	10.80	11.60	16.90	18.20	23.00	24.80	29.20	31.40	35.30	38.00	1-1/8 X 12
1-1/4 X 12	1.250	1.875	2.500	3.125	3.750	1.37	1.47	12.20	13.10	19.00	20.40	25.80	27.80	32.70	35.10	39.50	42.50	1-1/4 X 12
1-3/8 X 12	1.375	2.062	2.750	3.437	4.125	1.50	1.61	13.50	14.60	21.00	22.70	28.50	30.80	36.00	38.80	43.50	46.90	1-3/8 X 12
1-1/2 X 12	1.500	2.250	3.000	3.750	4.500	1.62	1.75	14.90	16.10	23.10	24.90	31.30	33.70	39.50	42.60	47.70	51.40	1-1/2 X 12
1-1/2 X 12	1.500	2.250	3.000	3.750	4.500	1.62	1.75	14.90	16.10	23.10	24.90	31.30	33.70	39.50	42.60	47.70	51.40	1-1/2 X 12

Optimum thread performance with Wire Thread Inserts is achieved when the inserts are installed 1/2 to 1 pitch below the surface of the tapped hole. This means that the actual length of an installed insert is equal to dimension Q less 1/2 to 1 pitch. Dimensions S and T allow for tap end clearance of intermediate taps. When using Bottoming and Spiral Flute Taps these dimensions may be reduced by an amount equal to 2 thread pitches. Any countersink depths must be added to these dimensions.

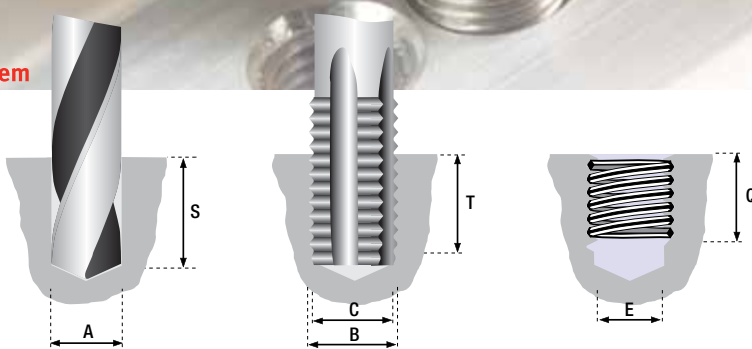

Nominal Thread Size	DRILLED HOLE DIMENSIONS									Nominal Thread Size	TAPPED HOLE DIMENSIONS									E Fitted Minor Dia.
	Drill		S Min. Drilling Depth Inter/Plug Tap					B Major Dia.	C Pitch Diameter			T Minimum Tapping Depth								
	Size	A Minor Dia.	1D	1.5D	2D	2.5D	3D		Min		Close	Medium	1D	1.5D	2D	2.5D	3D			
mm	inch	inch	inch	inch	inch	inch	inch	inch	inch	inch	inch	inch	inch	inch	inch	inch				
BSW										BSW										
1/8 X 40	3.40	#30	0.129	0.135	0.237	0.300	0.362	0.425	0.487	1/8 X 40	0.155	0.1410	0.1420	0.1430	0.212	0.275	0.337	0.400	0.462	0.0930
3/16 X 24	5.00	13/64	0.196	0.202	0.375	0.469	0.562	0.656	0.750	3/16 X 24	0.237	0.2142	0.2154	0.2166	0.333	0.427	0.521	0.614	0.708	0.1341
1/4 X 20	6.70	17/64	0.261	0.267	0.475	0.600	0.725	0.850	0.975	1/4 X 20	0.309	0.2820	0.2836	0.2849	0.425	0.550	0.675	0.800	0.925	0.1860
5/16 X 18	8.30	21/64	0.328	0.334	0.562	0.718	0.875	1.031	1.187	5/16 X 18	0.378	0.3480	0.3498	0.3512	0.507	0.663	0.819	0.975	1.132	0.2413
3/8 X 16	10.00	25/64	0.390	0.398	0.656	0.844	1.031	1.219	1.406	3/8 X 16	0.448	0.4150	0.4170	0.4185	0.594	0.781	0.969	1.156	1.344	0.2950
7/16 X 14	11.60	29/64	0.453	0.463	0.758	0.977	1.196	1.415	1.633	7/16 X 14	0.521	0.4833	0.4855	0.4871	0.687	0.906	1.125	1.344	1.562	0.3461
1/2 X 12	13.00	33/64	0.515	0.525	0.875	1.125	1.375	1.625	1.875	1/2 X 12	0.597	0.5533	0.5557	0.5575	0.792	1.042	1.292	1.542	1.792	0.3932
9/16 X 12	14.80	37/64	0.578	0.588	0.937	1.219	1.500	1.781	2.062	9/16 X 12	0.660	0.6158	0.6184	0.6201	0.854	1.135	1.417	1.698	1.979	0.4557
5/8 X 11	16.70	21/32	0.653	0.663	1.034	1.347	1.659	1.972	2.284	5/8 X 11	0.731	0.6832	0.6859	0.6878	0.943	1.256	1.568	1.881	2.193	0.5086
3/4 X 10	20.00	25/32	0.781	0.791	1.200	1.575	1.950	2.325	2.700	3/4 X 10	0.867	0.8141	0.8171	0.8191	1.100	1.475	1.850	2.225	2.600	0.6220
7/8 X 9	23.20	29/32	0.906	0.916	1.375	1.812	2.250	2.687	3.125	7/8 X 9	1.005	0.9462	0.9495	0.9516	1.264	1.701	2.139	2.576	3.014	0.7328
1 X 8	26.50	1.1/32	1.031	1.044	1.562	2.062	2.562	3.062	3.562	1 X 8	1.146	1.0801	1.0836	1.0859	1.437	1.937	2.437	2.937	3.437	0.8400
1-1/8 X 7	30.00	1.11/64	1.171	1.186	1.768	2.330	2.893	3.455	4.018	1-1/8 X 7	1.291	1.2165	1.2203	1.2227	1.625	2.187	2.750	3.312	3.875	0.9420
1-1/4 X 7	33.00	1.19/64	1.296	1.311	1.893	2.518	3.143	3.768	4.393	1-1/4 X 7	1.416	1.3415	1.3454	1.3479	1.750	2.375	3.000	3.625	4.250	1.0670
1-1/2 X 6	39.50	1.35/64	1.546	1.571	2.250	3.000	3.750	4.500	5.250	1-1/2 X 6	1.694	1.6067	1.6110	1.6137	2.083	2.833	3.583	4.333	5.083	1.2866
BSF										BSF										
3/16 X 32	5.00	13/64	0.192	0.198	0.328	0.422	0.515	0.609	0.703	3/16 X 32	0.225	0.2075	0.2087	0.2098	0.297	0.390	0.484	0.578	0.672	0.1475
1/4 X 26	6.60	17/64	0.257	0.264	0.423	0.548	0.673	0.798	0.923	1/4 X 26	0.296	0.2747	0.2762	0.2774	0.385	0.510	0.635	0.760	0.885	0.2008
5/16 X 22	8.30	21/64	0.323	0.330	0.517	0.673	0.829	0.986	1.142	5/16 X 22	0.366	0.3416	0.3433	0.3447	0.472	0.628	0.784	0.940	1.096	0.2543
3/8 X 20	9.80	25/64	0.385	0.392	0.600	0.787	0.975	1.162	1.350	3/8 X 20	0.434	0.4070	0.4089	0.4104	0.550	0.737	0.925	1.112	1.300	0.3110
7/16 X 18	11.60	29/64	0.450	0.458	0.687	0.906	1.124	1.343	1.562	7/16 X 18	0.503	0.4730	0.4751	0.4767	0.632	0.851	1.069	1.288	1.507	0.3663
1/2 X 16	13.20	33/64	0.513	0.522	0.781	1.031	1.281	1.531	1.781	1/2 X 16	0.574	0.5400	0.5423	0.5440	0.719	0.969	1.219	1.469	1.719	0.4200
9/16 X 16	14.80	37/64	0.577	0.586	0.844	1.125	1.406	1.687	1.969	9/16 X 16	0.636	0.6025	0.6049	0.6067	0.781	1.062	1.344	1.625	1.906	0.4825
5/8 X 14	16.30	41/64	0.640	0.649	0.946	1.259	1.571	1.884	2.196	5/8 X 14	0.709	0.6708	0.6734	0.6752	0.875	1.187	1.500	1.812	2.125	0.5336
3/4 X 12	19.50	49/64	0.765	0.775	1.125	1.500	1.875	2.250	2.625	3/4 X 12	0.848	0.8033	0.8062	0.8082	1.042	1.417	1.792	2.167	2.542	0.6432
7/8 X 11	22.80	57/64	0.890	0.900	1.284	1.722	2.159	2.596	3.034	7/8 X 11	0.982	0.9332	0.9364	0.9384	1.193	1.631	2.068	2.506	2.943	0.7586
1 X 10	26.20	1.1/32	1.031	1.044	1.450	1.950	2.450	2.950	3.450	1 X 10	1.117	1.0641	1.0675	1.0697	1.350	1.850	2.350	2.850	3.350	0.8720
1-1/8 X 9	29.50	1.5/32	1.156	1.170	1.625	2.187	2.750	3.312	3.875	1-1/8 X 9	1.255	1.1962	1.1998	1.2021	1.514	2.076	2.639	3.201	3.764	0.9828
1-1/4 X 9	32.50	1.9/32	1.281	1.295	1.750	2.375	3.000	3.625	4.250	1-1/4 X 9	1.380	1.3212	1.3250	1.3274	1.639	2.264	2.889	3.514	4.139	1.1078
1-3/8 X 8	36.00	1.13/32	1.406	1.420	1.937	2.625	3.312	4.000	4.687	1-3/8 X 8	1.521	1.4551	1.4591	1.4616	1.812	2.500	3.187	3.875	4.562	1.2150
1-1/2 X 8	39.00	1.17/32	1.531	1.545	2.062	2.812	3.562	4.312	5.062	1-1/2 X 8	1.646	1.5801	1.5843	1.5868	1.937	2.687	3.437	4.187	4.937	1.3400
BSP										BSP										
1/8 X 28	10.00	25/64	0.390	0.400	0.286	0.348	0.411	0.437	0.536	1/8 X 28	0.426	0.4058	0.4076	0.4090	0.250	0.312	0.375	0.437	0.500	0.3372
1/4 X 19	13.60	17/32	0.530	0.540	0.487	0.612	0.737	0.862	0.987	1/4 X 19	0.580	0.5517	0.5539	0.5556	0.434	0.559	0.684	0.809	0.934	0.4506
3/8 X 19	17.10	43/64	0.670	0.680	0.612	0.799	0.987	1.174	1.362	3/8 X 19	0.718	0.6897	0.6920	0.6937	0.559	0.747	0.934	1.122	1.309	0.5886
1/2 X 14	21.50	27/32	0.840	0.850	0.821	1.071	1.321	1.571	1.821	1/2 X 14	0.909	0.8708	0.8735	0.8754	0.750	1.000	1.250	1.500	1.750	0.7336
5/8 X 14	23.40	59/64	0.915	0.927	0.946	1.258	1.571	1.883	2.196	5/8 X 14	0.986	0.9478	0.9506	0.9524	0.875	1.187	1.500	1.812	2.125	0.8106
3/4 X 14	27.00	1.1/16	1.053	1.066	1.071	1.446	1.821	2.196	2.571	3/4 X 14	1.126	1.0868	1.0898	1.0918	1.000	1.375	1.750	2.125	2.500	0.9496
7/8 X 14	30.50	1.13/64	1.200	1.213	1.196	1.634	2.071	2.509	2.946	7/8 X 14	1.274	1.2348	1.2378	1.2399	1.125	1.562	2.000	2.437	2.875	1.0976
1 X 11	33.70	1.21/64	1.320	1.335	1.409	1.909	2.409	2.909	3.409	1 X 11	1.416	1.3673	1.3705	1.3727	1.318	1.818	2.318	2.818	3.318	1.1926
1-1/4 X 11	42.50	1.43/64	1.665	1.680	1.660	2.284	2.909	3.534	4.159	1-1/4 X 11	1.757	1.7083	1.7118	1.7141	1.568	2.193	2.818	3.443	4.068	1.5336
1-1/2 X 11	48.50	1.29/32	1.906	1.921	1.909	2.659	3.409	4.159	4.909	1-1/2 X 11	1.989	1.9403	1.9440	1.9464	1.818	2.568	3.318	4.068	4.818	1.7656

IMPORTANT The success of any drilling and tapping operation is dependant upon many factors – type of material being cut, cutting speed, coolant, equipment being used – and it is not possible to give specific drill sizes for each material. Drill sizes shown are recommendations only and PowerCoil would strongly suggest that independent testing be performed for specific and critical applications.

When using wire thread inserts it is important that the drilling and tapping diameters and lengths listed below are adhered to.

The figures outlined in these tables encompass effective free coil tolerances for most globally recognized standards and manufacturers, including those of reduced diameter wire thread inserts.

PowerCoil wire thread inserts can be manufactured to different standards upon request. Technical data on these standards can be obtained from our website – www.powercoil.com.au.

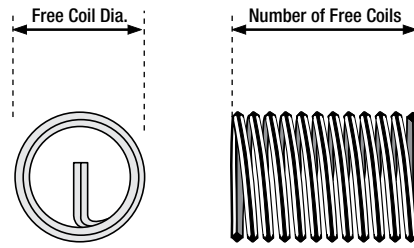

Nominal Thread Size	INSERT SPECIFICATIONS																Nominal Thread Size	
	Q Nominal Length – installed					Free Coil Diameter		Number of Free Coils ± 1/4 coil counted 90° from Tang										
	1D	1.5D	2D	2.5D	3D	Min	Max	1D		1.5D		2D		2.5D		3D		
	inch	inch	inch	inch	inch	inch	inch	Min	Max	Min	Max	Min	Max	Min	Max	Min		Max
BSW																		
1/8 X 40	0.125	0.187	0.250	0.312	0.375	0.15	0.17	3.00	3.40	5.10	5.80	7.30	8.40	9.40	10.90	11.60	13.40	1/8 X 40
3/16 X 24	0.187	0.281	0.375	0.469	0.562	0.23	0.26	2.60	2.90	4.60	5.10	6.60	7.40	8.70	9.70	10.70	11.90	3/16 X 24
1/4 X 20	0.250	0.375	0.500	0.625	0.750	0.31	0.33	3.10	3.40	5.40	5.90	7.70	8.50	9.90	11.00	12.20	13.50	1/4 X 20
5/16 X 18	0.312	0.469	0.625	0.781	0.937	0.37	0.40	3.80	4.10	6.40	6.90	9.00	9.80	11.60	12.60	14.20	15.50	5/16 X 18
3/8 X 16	0.375	0.562	0.750	0.937	1.125	0.44	0.47	4.10	4.40	6.90	7.40	9.70	10.50	12.50	13.50	15.30	16.50	3/8 X 16
7/16 X 14	0.437	0.656	0.875	1.094	1.312	0.52	0.55	4.20	4.60	7.10	7.60	9.90	10.70	12.80	13.80	15.60	16.90	7/16 X 14
1/2 X 12	0.500	0.750	1.000	1.250	1.500	0.59	0.63	4.10	4.50	7.00	7.40	9.80	10.50	12.60	13.60	15.40	16.60	1/2 X 12
9/16 X 12	0.562	0.844	1.125	1.406	1.687	0.65	0.69	4.90	5.20	8.00	8.60	11.20	12.00	14.40	15.40	17.60	18.80	9/16 X 12
5/8 X 11	0.625	0.937	1.250	1.562	1.875	0.72	0.77	5.00	5.30	8.20	8.70	11.50	12.20	14.70	15.70	17.90	19.20	5/8 X 11
3/4 X 10	0.750	1.125	1.500	1.875	2.250	0.86	0.90	5.60	6.00	9.20	9.70	12.70	13.50	16.30	17.30	19.80	21.10	3/4 X 10
7/8 X 9	0.875	1.312	1.750	2.187	2.625	0.99	1.05	6.00	6.30	9.70	10.20	13.40	14.30	17.10	18.20	20.90	22.20	7/8 X 9
1 X 8	1.000	1.500	2.000	2.500	3.000	1.13	1.20	6.10	6.50	9.90	10.40	13.70	14.50	17.50	18.60	21.20	22.60	1 X 8
1-1/8 X 7	1.125	1.687	2.250	2.812	3.375	1.28	1.35	5.90	6.30	9.60	10.20	13.40	14.30	17.10	18.20	20.80	22.20	1-1/8 X 7
1-1/4 X 7	1.250	1.875	2.500	3.125	3.750	1.40	1.48	6.80	7.20	10.90	11.60	15.00	16.00	19.20	20.40	23.30	24.90	1-1/4 X 7
1-1/2 X 6	1.500	2.250	3.000	3.750	4.500	1.68	1.78	7.00	7.50	11.30	11.90	15.50	16.50	19.80	21.10	24.00	25.60	1-1/2 X 6
BSF																		
3/16 X 32	0.187	0.281	0.375	0.469	0.562	0.23	0.25	3.90	4.30	6.50	7.20	9.20	10.20	11.90	13.10	14.50	16.00	3/16 X 32
1/4 X 26	0.250	0.375	0.500	0.625	0.750	0.30	0.33	4.30	4.80	7.10	7.90	9.90	11.20	12.70	14.40	15.60	17.50	1/4 X 26
5/16 X 22	0.312	0.469	0.625	0.781	0.937	0.37	0.40	4.70	5.20	7.70	8.50	10.70	11.90	13.80	15.30	16.80	18.70	5/16 X 22
3/8 X 20	0.375	0.562	0.750	0.937	1.125	0.44	0.48	5.30	5.80	8.60	9.40	12.00	13.20	15.30	16.90	18.70	20.50	3/8 X 20
7/16 X 18	0.437	0.656	0.875	1.094	1.312	0.51	0.56	5.60	6.20	9.10	10.00	12.60	13.90	16.10	17.80	19.60	21.60	7/16 X 18
1/2 X 16	0.500	0.750	1.000	1.250	1.500	0.58	0.63	5.70	6.30	9.30	10.20	12.90	14.20	16.50	18.10	20.00	22.00	1/2 X 16
9/16 X 16	0.562	0.844	1.125	1.406	1.687	0.64	0.70	6.60	7.30	10.60	11.70	14.70	16.10	18.70	20.60	22.70	25.00	9/16 X 16
5/8 X 14	0.625	0.937	1.250	1.562	1.875	0.72	0.77	6.50	7.10	10.40	11.30	14.30	15.70	18.30	20.00	22.20	24.30	5/8 X 14
3/4 X 12	0.750	1.125	1.500	1.875	2.250	0.86	0.92	6.70	7.30	10.80	11.70	14.90	16.20	19.00	20.70	23.00	25.10	3/4 X 12
7/8 X 11	0.875	1.312	1.750	2.187	2.625	0.99	1.07	7.20	7.90	11.60	12.60	15.90	17.40	20.30	22.10	24.60	26.90	7/8 X 11
1 X 10	1.000	1.500	2.000	2.500	3.000	1.13	1.22	7.60	8.30	12.10	13.20	16.60	18.10	21.20	23.10	25.70	28.00	1 X 10
1-1/8 X 9	1.125	1.687	2.250	2.812	3.375	1.27	1.37	7.80	8.40	12.30	13.30	17.00	18.40	21.50	23.40	26.10	28.40	1-1/8 X 9
1-1/4 X 9	1.250	1.875	2.500	3.125	3.750	1.39	1.50	8.80	9.50	13.90	15.00	19.00	20.60	24.20	26.20	29.30	31.70	1-1/4 X 9
1-3/8 X 8	1.375	2.062	2.750	3.437	4.125	1.54	1.66	8.50	9.30	13.50	14.60	18.50	20.10	23.50	25.50	28.50	31.00	1-3/8 X 8
1-1/2 X 8	1.500	2.250	3.000	3.750	4.500	1.66	1.81	9.40	10.30	14.80	16.10	20.10	22.10	25.50	28.00	30.90	33.90	1-1/2 X 8
BSP																		
1/8 X 28	0.125	0.187	0.250	0.312	0.375	0.43	0.47	1.70	1.90	3.20	3.60	4.80	5.30	6.40	7.00	7.90	8.80	1/8 X 28
1/4 X 19	0.250	0.375	0.500	0.625	0.750	0.59	0.64	2.80	3.10	5.00	5.40	7.10	7.80	9.20	10.10	11.40	12.50	1/4 X 19
3/8 X 19	0.375	0.562	0.750	0.937	1.125	0.73	0.79	5.00	5.50	8.20	8.90	11.40	12.50	14.60	16.00	17.90	19.50	3/8 X 19
1/2 X 14	0.500	0.750	1.000	1.250	1.500	0.92	0.99	4.90	5.30	8.10	8.80	11.20	12.20	14.40	15.70	17.60	19.10	1/2 X 14
5/8 X 14	0.625	0.937	1.250	1.562	1.875	1.00	1.08	6.50	7.10	10.40	11.30	14.40	15.70	18.40	20.00	22.30	24.30	5/8 X 14
3/4 X 14	0.750	1.125	1.500	1.875	2.250	1.14	1.23	8.10	8.80	12.90	13.90	17.60	19.20	22.40	24.30	27.20	29.50	3/4 X 14
7/8 X 14	0.875	1.312	1.750	2.187	2.625	1.29	1.39	9.70	10.50	15.30	16.50	20.80	22.60	26.40	28.70	32.00	34.70	7/8 X 14
1 X 11	1.000	1.500	2.000	2.500	3.000	1.43	1.54	8.60	9.30	13.60	14.70	18.60	20.10	23.60	25.60	28.60	31.00	1 X 11
1-1/4 X 11	1.250	1.875	2.500	3.125	3.750	1.77	1.91	11.10	12.00	17.40	18.70	23.70	25.60	30.00	32.40	36.20	39.20	1-1/4 X 11
1-1/2 X 11	1.500	2.250	3.000	3.750	4.500	2.01	2.16	13.60	14.70	21.20	22.80	28.70	31.00	36.30	39.20	43.80	47.30	1-1/2 X 11



Optimum thread performance with Wire Thread Inserts is achieved when the inserts are installed 1/2 to 1 pitch below the surface of the tapped hole. This means that the actual length of an installed insert is equal to dimension Q less 1/2 to 1 pitch. Dimensions S and T allow for tap end clearance of intermediate taps. When using Bottoming and Spiral Flute Taps these dimensions may be reduced by an amount equal to 2 thread pitches. Any countersink depths must be added to these dimensions.

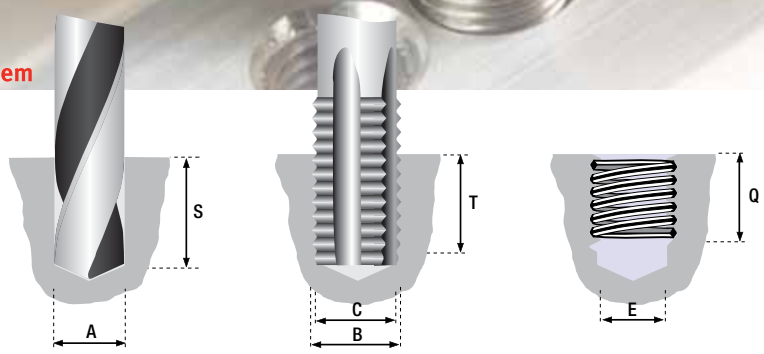

Nominal Thread Size	DRILLED HOLE DIMENSIONS									Nominal Thread Size	TAPPED HOLE DIMENSIONS							E Fitted Minor Dia.		
	Drill				S Min. Drilling Depth Inter/Plug Tap						B Major Dia.	C Pitch Diameter		T Minimum Tapping Depth						
	Size		A Minor Dia.		1D	1.5D	2D	2.5D	3D			Minimum	Normal	1D	1.5D	2D	2.5D		3D	
	mm	inch	inch	inch	inch	inch	inch	inch	inch			inch	inch	inch	inch	inch	inch		inch	
BA										BA										
6BA	2.90	#33	0.113	0.116	0.204	0.259	0.314	0.369	0.424	6BA	0.134	0.1226	0.1252	0.183	0.238	0.293	0.348	0.404	0.0850	
5BA	3.40	#29	0.129	0.135	0.230	0.293	0.356	0.419	0.482	5BA	0.152	0.1399	0.1426	0.207	0.270	0.333	0.396	0.459	0.0980	
4BA	3.80	#25	0.147	0.152	0.259	0.329	0.400	0.471	0.542	4BA	0.171	0.1574	0.1605	0.233	0.303	0.374	0.445	0.516	0.1106	
3BA	4.30	11/64	0.166	0.171	0.291	0.371	0.452	0.533	0.613	3BA	0.194	0.1786	0.1821	0.262	0.343	0.423	0.504	0.585	0.1268	
2BA	4.90	#10	0.191	0.196	0.328	0.421	0.513	0.606	0.698	2BA	0.221	0.2042	0.2079	0.297	0.389	0.482	0.574	0.667	0.1468	
1BA	5.50	7/32	0.213	0.220	0.368	0.472	0.576	0.681	0.785	1BA	0.249	0.2299	0.2342	0.333	0.437	0.541	0.646	0.750	0.1661	
0BA	6.20	C	0.241	0.246	0.413	0.531	0.649	0.768	0.886	0BA	0.281	0.2598	0.2645	0.374	0.492	0.610	0.728	0.846	0.1890	

Nominal Thread Size	DRILLED HOLE DIMENSIONS									Nominal Thread Size	TAPPED HOLE DIMENSIONS							E Fitted Minor Dia.		
	Drill				S Min. Drilling Depth Inter/Plug Tap						B Major Dia.	C Pitch Diameter		T Minimum Tapping Depth						
	Size		A Minor Dia.		1D	1.5D	2D	2.5D	3D			Minimum	Normal	1D	1.5D	2D	2.5D		3D	
	mm	inch	inch	inch	inch	inch	inch	inch	inch			inch	inch	inch	inch	inch	inch		inch	
BSC										BSC										
3/16 X 32	5.10	13/64	0.195	0.205	0.330	0.420	0.520	0.610	0.700	3/16 X 32	0.232	0.2136	0.2112	0.300	0.390	0.480	0.580	0.670	0.1543	
1/4 X 26	6.60	17/64	0.258	0.270	0.420	0.550	0.670	0.800	0.920	1/4 X 26	0.304	0.2817	0.2790	0.380	0.510	0.630	0.760	0.880	0.2090	
5/16 X 26	8.00	5/16	0.320	0.332	0.490	0.640	0.800	0.950	1.110	5/16 X 26	0.367	0.3444	0.3415	0.450	0.600	0.760	0.920	1.070	0.2715	
3/8 X 26	9.80	25/64	0.383	0.395	0.550	0.740	0.920	1.110	1.300	3/8 X 26	0.429	0.4070	0.4040	0.510	0.700	0.880	1.070	1.260	0.3340	
7/16 X 26	11.10	7/16	0.446	0.457	0.610	0.830	1.050	1.270	1.490	7/16 X 26	0.492	0.4697	0.4665	0.570	0.790	1.010	1.230	1.450	0.3965	
1/2 X 26	12.70	1/2	0.508	0.520	0.670	0.920	1.170	1.420	1.670	1/2 X 26	0.554	0.5323	0.5290	0.630	0.880	1.130	1.380	1.630	0.4590	
9/16 X 26	14.75	37/64	0.571	0.582	0.740	1.020	1.300	1.580	1.860	9/16 X 26	0.617	0.5945	0.5915	0.700	0.980	1.260	1.540	1.820	0.5215	
5/8 X 26	16.30	41/64	0.633	0.645	0.800	1.110	1.420	1.740	2.050	5/8 X 26	0.679	0.6575	0.6540	0.760	1.070	1.380	1.700	2.010	0.5840	
3/4 X 26	19.50	49/64	0.758	0.769	0.920	1.300	1.670	2.050	2.420	3/4 X 26	0.804	0.7827	0.7790	0.880	1.260	1.630	2.010	2.380	0.7090	
1 X 24	25.75	1.1/64	1.009	1.020	1.190	1.690	2.190	2.690	3.190	1 X 24	1.059	1.0355	1.0314	1.150	1.650	2.150	2.650	3.150	0.9556	

Nominal Thread Size	DRILLED HOLE DIMENSIONS									Nominal Thread Size	TAPPED HOLE DIMENSIONS							E Fitted Minor Dia.		
	Drill				S Min. Drilling Depth Inter/Plug Tap						B Major Dia.	C Pitch Dia.		Tap Std.	T Minimum Tapping Depth					
	Size		A Minor Dia.		1D	1.5D	2D	2.5D	3D			Min	3B		1D	1.5D	2D		2.5D	3D
	mm	inch	inch	inch	inch	inch	inch	inch	inch			inch	inch		inch	inch	inch		inch	inch
8-UN										8-UN										
1.1/8 X 8	28.50	1.1/8	1.130	1.155	1.690	2.250	2.810	3.380	3.940	1.1/8 X 8	1.261	1.1688	1.1757	1.1/4	1.560	2.130	2.690	3.250	3.810	-
1.1/4 X 8	32.00	1.1/4	1.255	1.280	1.810	2.440	3.060	3.690	4.310	1.1/4 X 8	1.386	1.2938	1.3008	1.3/8	1.690	2.310	2.940	3.560	4.190	-
1.3/8 X 8	35.00	1.3/8	1.380	1.405	1.940	2.620	3.310	4.000	4.690	1.3/8 X 8	1.511	1.4188	1.4259	1.1/2	1.810	2.500	3.190	3.880	4.560	-
1.1/2 X 8	38.00	1.1/2	1.505	1.530	2.060	2.810	3.560	4.310	5.060	1.1/2 X 8	1.636	1.5438	1.5510	1.5/8	1.940	2.690	3.440	4.190	4.940	-
1.5/8 X 8	41.00	1.5/8	1.630	1.655	2.190	3.000	3.810	4.630	5.440	1.5/8 X 8	1.761	1.6688	1.6762	1.3/4	2.060	2.880	3.690	4.500	5.310	-
1.3/4 X 8	44.50	1.3/4	1.755	1.780	2.310	3.190	4.060	4.940	5.810	1.3/4 X 8	1.886	1.7938	1.8013	1.7/8	2.190	3.060	3.940	4.810	5.690	-
1.7/8 X 8	47.50	1.7/8	1.880	1.905	2.440	3.370	4.310	5.250	6.190	1.7/8 X 8	2.011	1.9188	1.9264	2	2.310	3.250	4.190	5.130	6.060	-
2 X 8	50.80	2	2.005	2.030	2.560	3.560	4.560	5.560	6.560	2 X 8	2.136	2.0438	2.0515	2.1/8	2.440	3.440	4.440	5.440	6.440	-

IMPORTANT The success of any drilling and tapping operation is dependant upon many factors –type of material being cut, cutting speed, coolant, equipment being used – and it is not possible to give specific drill sizes for each material. Drill sizes shown are recommendations only and PowerCoil would strongly suggest that independent testing be performed for specific and critical applications.

When using wire thread inserts it is important that the drilling and tapping diameters and lengths listed below are adhered to.

The figures outlined in these tables encompass effective free coil tolerances for most globally recognized standards and manufacturers, including those of reduced diameter wire thread inserts.

PowerCoil wire thread inserts can be manufactured to different standards upon request. Technical data on these standards can be obtained from our website – www.powercoil.com.au.

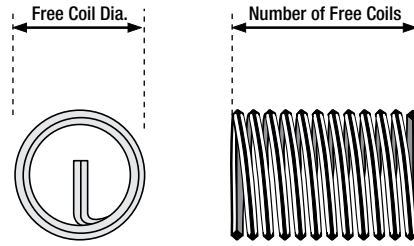

Nominal Thread Size	INSERT SPECIFICATIONS																Nominal Thread Size	
	Q Nominal Length – installed					Free Coil Diameter		Number of Free Coils ± 1/4 coil counted 90° from Tang										
	1D	1.5D	2D	2.5D	3D	Min	Max	1D		1.5D		2D		2.5D		3D		
	inch	inch	inch	inch	inch	inch	inch	Min	Max	Min	Max	Min	Max	Min	Max	Min		Max
BA																	BA	
6BA	0.110	0.165	0.220	0.275	0.331	0.14	0.15	3.30	3.60	5.60	6.20	7.90	8.70	10.20	11.20	12.50	13.80	6BA
5BA	0.126	0.189	0.252	0.315	0.378	0.15	0.17	3.40	3.80	5.80	6.40	8.10	9.00	10.50	11.60	12.90	14.20	5BA
4BA	0.142	0.212	0.283	0.354	0.425	0.17	0.19	3.50	3.80	5.80	6.40	8.20	9.10	10.60	11.70	13.00	14.40	4BA
3BA	0.161	0.242	0.323	0.403	0.484	0.20	0.21	3.60	3.90	6.00	6.70	8.50	9.40	10.90	12.10	13.40	14.80	3BA
2BA	0.185	0.277	0.370	0.462	0.555	0.22	0.24	3.80	4.20	6.30	6.90	8.80	9.80	11.40	12.60	13.90	15.40	2BA
1BA	0.209	0.313	0.417	0.522	0.626	0.25	0.27	3.80	4.20	6.40	7.10	9.00	9.90	11.60	12.80	14.10	15.60	1BA
0BA	0.236	0.354	0.472	0.590	0.709	0.28	0.31	3.90	4.30	6.60	7.20	9.20	10.10	11.80	13.00	14.50	16.00	0BA
BSC																	BSC	
3/16 X 32	0.187	0.281	0.375	0.469	0.562	0.23	0.26	3.70	4.10	6.20	6.90	8.70	9.70	11.20	12.50	13.70	15.30	3/16 X 32
1/4 X 26	0.250	0.375	0.500	0.625	0.750	0.31	0.34	4.10	4.60	6.90	7.60	9.60	10.70	12.30	13.80	15.10	16.80	1/4 X 26
5/16 X 26	0.312	0.469	0.625	0.781	0.937	0.37	0.41	5.50	6.20	9.00	10.00	12.50	13.90	16.00	17.80	19.40	21.60	5/16 X 26
3/8 X 26	0.375	0.562	0.750	0.937	1.125	0.43	0.48	7.00	7.80	11.20	12.40	15.40	17.10	19.60	21.70	23.80	26.40	3/8 X 26
7/16 X 26	0.437	0.656	0.875	1.094	1.312	0.50	0.55	8.40	9.40	13.40	14.80	18.30	20.30	23.30	25.80	28.20	31.20	7/16 X 26
1/2 X 26	0.500	0.750	1.000	1.250	1.500	0.56	0.61	9.90	11.00	15.60	17.20	21.20	23.50	26.90	29.80	32.60	36.00	1/2 X 26
9/16 X 26	0.562	0.844	1.125	1.406	1.687	0.62	0.68	11.40	12.60	17.80	19.70	24.20	26.70	30.50	33.80	36.90	40.90	9/16 X 26
5/8 X 26	0.625	0.937	1.250	1.562	1.875	0.69	0.75	12.80	14.20	19.90	22.00	27.10	29.90	34.20	37.80	41.30	45.70	5/8 X 26
3/4 X 26	0.750	1.125	1.500	1.875	2.250	0.81	0.89	15.70	17.40	24.30	26.90	32.90	36.30	41.50	45.80	50.10	55.30	3/4 X 26
1 X 24	1.000	1.500	2.000	2.500	3.000	1.07	1.17	19.80	21.80	30.40	33.50	41.00	45.30	51.60	57.00	62.20	68.70	1 X 24

Nominal Thread Size	INSERT SPECIFICATIONS																Nominal Thread Size	
	Q Nominal Length – installed					Free Coil Diameter		Number of Free Coils ± 1/4 coil counted 90° from Tang										
	1D	1.5D	2D	2.5D	3D	Min	Max	1D		1.5D		2D		2.5D		3D		
	inch	inch	inch	inch	inch	inch	inch	Min	Max	Min	Max	Min	Max	Min	Max	Min		Max
8-UN																	8-UN	
1.1/8 X 8	1.125	1.688	2.250	2.81	3.38	1.25	1.30	7.10	7.50	11.50	12.00	15.80	16.60	20.10	21.10	24.50	25.60	1.1/8 X 8
1.1/4 X 8	1.250	1.875	2.500	3.13	3.75	1.39	1.43	8.10	8.30	12.90	13.30	17.70	18.30	22.60	23.30	27.40	28.20	1.1/4 X 8
1.3/8 X 8	1.375	2.062	2.750	3.44	4.13	1.52	1.57	9.00	9.30	14.30	14.80	19.60	20.20	24.90	25.70	30.20	31.20	1.3/8 X 8
1.1/2 X 8	1.500	2.250	3.000	3.75	4.50	1.65	1.69	10.00	10.30	15.80	16.20	21.50	22.20	27.30	28.10	33.10	34.10	1.1/2 X 8
1.5/8 X 8	1.625	2.438	3.250	4.06	4.88	1.78	1.90	10.50	11.20	16.40	17.70	22.40	24.10	28.40	30.50	34.30	37.00	1.5/8 X 8
1.3/4 X 8	1.750	2.625	3.500	4.38	5.25	1.90	2.04	11.40	12.20	17.80	19.20	24.20	26.10	30.70	33.00	37.10	39.90	1.3/4 X 8
1.7/8 X 8	1.875	2.812	3.750	4.69	5.63	2.03	2.16	12.40	13.20	19.30	20.60	26.20	28.10	33.20	35.50	40.10	42.90	1.7/8 X 8
2 X 8	2.000	3.000	4.000	5.00	6.00	2.16	2.28	13.40	14.20	20.90	22.10	28.40	30.00	35.90	38.00	43.30	45.90	2 X 8

THIN WALL AND HEAVY DUTY LOKSERTS

Insert Material Carbon Steel – C1215 or equivalent
Stainless Steel – 303 or equivalent
Keys 302 CRES or equivalent
Finish Carbon Steel – Zinc Phosphate;
Stainless Steel – Passivated
Tolerances ±0.010 inch or ±0.25mm
unless specified otherwise

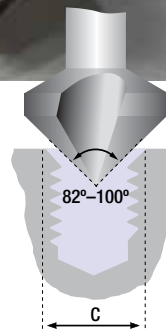
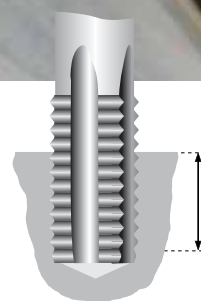
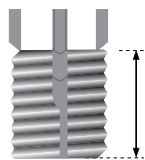

Internal Thread Class 6G	INSERT SPECIFICATIONS			Internal Thread Class 6G	DRILL, TAP & COUNTERSINK SPECIFICATIONS				Internal Thread Class 6G	REMOVAL SPECIFICATIONS	
	External Thread Class 6G	Q Nominal Length	Installation Tool		A Drill Size	Tap Size Class 6H	T Minimum Tapping Depth	C Min. Width Countersink		R1 Drill Size	R2 Minimum Drilling Depth
mm	mm	mm	Part #	mm	mm	mm	mm	mm	mm	mm	mm
THIN WALL				THIN WALL				THIN WALL			
M5 X 0.8	M8 X 1.25	8.0	3600-190T	M5 X 0.8	6.90	M8 X 1.25	9.50	8.25	M5 X 0.8	5.50	4.00
M6 X 1.0	M10 X 1.25	10.0	3600-250T	M6 X 1.0	8.80	M10 x 1.25	11.50	10.25	M6 X 1.0	7.50	4.75
M8 X 1.25	M12 x 1.25	12.0	3600-312T	M8 X 1.25	10.80	M12 x 1.25	13.50	12.25	M8 X 1.25	9.50	4.75
M8 X 1.0	M12 x 1.25	12.0	3600-312T	M8 X 1.0	10.80	M12 x 1.25	13.50	12.25	M8 X 1.0	9.50	4.75
M10 X 1.5	M14 x 1.5	14.0	3600-375T	M10 X 1.5	12.80	M14 x 1.5	15.50	14.25	M10 X 1.5	11.50	4.75
M10 X 1.25	M14 x 1.5	14.0	3600-375T	M10 X 1.25	12.80	M14 x 1.5	15.50	14.25	M10 X 1.25	11.50	4.75
M12 X 1.75	M16 x 1.5	16.0	3600-500T	M12 X 1.75	14.75	M16 x 1.5	17.50	16.25	M12 X 1.75	13.50	4.75
M12 X 1.25	M16 x 1.5	16.0	3600-500T	M12 X 1.25	14.75	M16 x 1.5	17.50	16.25	M12 X 1.25	13.50	4.75
HEAVY DUTY				HEAVY DUTY				HEAVY DUTY			
M4 X 0.7	M8 X 1.25	8.0	3600-4.00HT	M4 X 0.7	6.90	M8 X 1.25	9.50	8.25	M4 X 0.7	5.50	4.00
M5 X 0.8	M10 X 1.25	10.0	3600-190T	M5 X 0.8	8.80	M10 x 1.25	12.50	10.25	M5 X 0.8	7.50	4.75
M6 X 1.0	M12 x 1.25	12.0	3600-250T	M6 X 1.0	10.80	M12 x 1.25	14.50	12.25	M6 X 1.0	9.50	4.75
M8 X 1.25	M14 x 1.5	14.0	3600-312T	M8 X 1.25	12.80	M14 x 1.5	16.50	14.25	M8 X 1.25	11.50	4.75
M8 X 1.0	M14 x 1.5	14.0	3600-312T	M8 X 1.0	12.80	M14 x 1.5	16.50	14.25	M8 X 1.0	11.50	4.75
M10 X 1.5	M16 x 1.5	16.0	3600-375T	M10 X 1.5	14.75	M16 x 1.5	18.50	16.25	M10 X 1.5	13.50	4.75
M10 X 1.25	M16 x 1.5	16.0	3600-375T	M10 X 1.25	14.75	M16 x 1.5	18.50	16.25	M10 X 1.25	13.50	4.75
M12 X 1.75	M18 x 1.5	18.0	3600-500T	M12 X 1.75	16.75	M18 X 1.5	20.50	18.25	M12 X 1.75	15.50	4.75
M12 X 1.25	M18 x 1.5	18.0	3600-500T	M12 X 1.25	16.75	M18 X 1.5	20.50	18.25	M12 X 1.25	15.50	4.75
M14 X 2.0	M20 X 1.5	20.0	3600-14.00HT	M14 X 2.0	18.75	M20 X 1.5	22.50	20.25	M14 X 2.0	17.50	4.75
M14 X 1.5	M20 X 1.5	20.0	3600-14.00HT	M14 X 1.5	18.75	M20 X 1.5	22.50	20.25	M14 X 1.5	17.50	4.75
M16 X 2.0	M22 X 1.5	22.0	3600-625T	M16 X 2.0	20.50	M22 X 1.5	24.50	22.25	M16 X 2.0	17.75	6.35
M16 X 1.5	M22 X 1.5	22.0	3600-625T	M16 X 1.5	20.50	M22 X 1.5	24.50	22.25	M16 X 1.5	17.75	6.35
M18 X 1.5	M24 X 1.5	24.0	3600-18.00HT	M18 X 1.5	22.50	M24 X 1.5	26.50	24.25	M18 X 1.5	19.75	6.35
M20 X 2.5	M30 X 2.0	30.0	3600-875T	M20 X 2.5	28.00	M30 X 2.0	34.50	30.25	M20 X 2.5	25.75	6.35
M20 X 1.5	M30 X 2.0	30.0	3600-875T	M20 X 1.5	28.00	M30 X 2.0	34.50	30.25	M20 X 1.5	25.75	6.35
M22 X 1.5	M32 X 2.0	32.0	3600-22.00HT	M22 X 1.5	30.00	M32 X 2.0	36.50	32.25	M22 X 1.5	27.75	6.35
M24 X 3.0	M33 X 2.0	33.0	3600-24.00HT	M24 X 3.0	31.00	M33 X 2.0	37.50	33.25	M24 X 3.0	28.75	6.35
M24 X 2.0	M33 X 2.0	33.0	3600-24.00HT	M24 X 2.0	31.00	M33 X 2.0	37.50	33.25	M24 X 2.0	28.75	6.35

REMOVAL



1 DRILL

Drill out the material between the locking keys and the internal thread to the specified depth.

Note: Drill size and drilling depth are shown in the loksert technical tables.

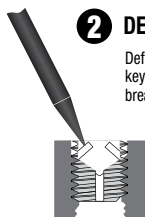

2 DEFLECT

Deflect locking keys inward and break off

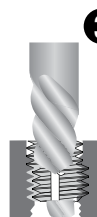

3 REMOVE

Remove the insert from the hole by winding it out using a screw extractor or similar type tool.

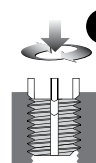

4 INSERT

A new loksert insert of exactly the same size can be installed in the original hole.

THIN WALL AND HEAVY DUTY LOKSERTS

Keys Inserts with internal thread of 5/16" (M7) or larger have 4 locking keys. Smaller sizes have 2 keys.

Tap Drill Hole 0.234 - 0.500 = +0.004 / -0.001
Tolerance Inch over 0.500 = +0.005 / -0.001

Tap Drill Hole 6.90 - 10.80 = +0.100 / -0.025
Tolerance Metric over 12.80 = +0.130 / -0.025

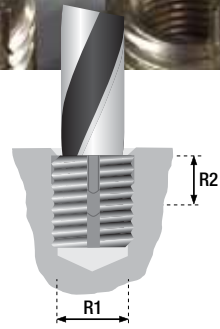

Internal Thread Class 2B	INSERT SPECIFICATIONS			Internal Thread Class 2B	DRILL, TAP & COUNTERSINK SPECIFICATIONS				Internal Thread Class 2B	REMOVAL SPECIFICATIONS	
	External Thread Mod Class 2A	Q Nominal Length	Installation Tool		A Drill Size	Tap Size Class 2B	T Minimum Tapping Depth	C Min. Width Countersink		R1 Drill Size	R2 Minimum Drilling Depth
inch	inch	inch	Part #	inch	inch	inch	inch	inch	inch	inch	inch
THIN WALL				THIN WALL				THIN WALL			
10G X 24	5/16 X 18	0.31	3600-190T	10G X 24	"I"	5/16 X 18	0.37	0.32	10G X 24	7/32	1/8
10G X 32	5/16 X 18	0.31	3600-190T	10G X 32	"I"	5/16 X 18	0.37	0.32	10G X 32	7/32	1/8
1/4 X 20	3/8 X 16	0.37	3600-250T	1/4 X 20	"Q"	3/8 X 16	0.43	0.38	1/4 X 20	9/32	3/16
1/4 X 28	3/8 X 16	0.37	3600-250T	1/4 X 28	"Q"	3/8 X 16	0.43	0.38	1/4 X 28	9/32	3/16
5/16 X 18	7/16 X 14	0.43	3600-312T	5/16 X 18	"X"	7/16 X 14	0.50	0.44	5/16 X 18	11/32	3/16
5/16 X 24	7/16 X 14	0.43	3600-312T	5/16 X 24	"X"	7/16 X 14	0.50	0.44	5/16 X 24	11/32	3/16
3/8 X 16	1/2 X 13	0.50	3600-375T	3/8 X 16	29/64	1/2 X 13	0.56	0.51	3/8 X 16	13/32	3/16
3/8 X 24	1/2 X 13	0.50	3600-375T	3/8 X 24	29/64	1/2 X 13	0.56	0.51	3/8 X 24	13/32	3/16
7/16 X 14	9/16 X 12	0.56	3600-375T	7/16 X 14	33/64	9/16 X 12	0.62	0.57	7/16 X 14	15/32	3/16
7/16 X 20	9/16 X 12	0.56	3600-375T	7/16 X 20	33/64	9/16 X 12	0.62	0.57	7/16 X 20	15/32	3/16
1/2 X 13	5/8 X 11	0.62	3600-500T	1/2 X 13	37/64	5/8 X 11	0.68	0.63	1/2 X 13	17/32	3/16
1/2 X 20	5/8 X 11	0.62	3600-500T	1/2 X 20	37/64	5/8 X 11	0.68	0.63	1/2 X 20	17/32	3/16
HEAVY DUTY				HEAVY DUTY				HEAVY DUTY			
8G X 32	5/16 X 18	0.31	3600-8GHT	8G X 32	"I"	5/16 X 18	0.37	0.32	8G X 32	7/32	1/8
10G X 24	3/8 X 16	0.31	3600-190T	10G X 24	"Q"	3/8 X 16	0.37	0.38	10G X 24	9/32	1/8
10G X 32	3/8 X 16	0.31	3600-190T	10G X 32	"Q"	3/8 X 16	0.37	0.38	10G X 32	9/32	1/8
1/4 X 20	7/16 X 14	0.37	3600-250T	1/4 X 20	"X"	7/16 X 14	0.43	0.44	1/4 X 20	11/32	3/16
1/4 X 28	7/16 X 14	0.37	3600-250T	1/4 X 28	"X"	7/16 X 14	0.43	0.44	1/4 X 28	11/32	3/16
5/16 X 18	1/2 X 13	0.43	3600-312T	5/16 X 18	29/64	1/2 X 13	0.50	0.51	5/16 X 18	13/32	3/16
5/16 X 24	1/2 X 13	0.43	3600-312T	5/16 X 24	29/64	1/2 X 13	0.50	0.51	5/16 X 24	13/32	3/16
3/8 X 16	9/16 X 12	0.50	3600-375T	3/8 X 16	33/64	9/16 X 12	0.56	0.57	3/8 X 16	15/32	3/16
3/8 X 24	9/16 X 12	0.50	3600-375T	3/8 X 24	33/64	9/16 X 12	0.56	0.57	3/8 X 24	15/32	3/16
7/16 X 14	5/8 X 11	0.62	3600-375T	7/16 X 14	37/64	5/8 X 11	0.68	0.63	7/16 X 14	17/32	3/16
7/16 X 20	5/8 X 11	0.62	3600-375T	7/16 X 20	37/64	5/8 X 11	0.68	0.63	7/16 X 20	17/32	3/16
1/2 X 13	3/4 X 16	0.62	3600-500T	1/2 X 13	45/64	3/4 X 16	0.68	0.76	1/2 X 13	21/32	3/16
1/2 X 20	3/4 X 16	0.62	3600-500T	1/2 X 20	45/64	3/4 X 16	0.68	0.76	1/2 X 20	21/32	3/16
9/16 X 12	3/4 X 16	0.81	3600-500T	9/16 X 12	45/64	3/4 X 16	0.94	0.76	9/16 X 12	21/32	3/16
9/16 X 18	3/4 X 16	0.81	3600-500T	9/16 X 18	45/64	3/4 X 16	0.94	0.76	9/16 X 18	21/32	3/16
5/8 X 11	7/8 X 14	0.87	3600-625T	5/8 X 11	53/64	7/8 X 14	1.00	0.88	5/8 X 11	25/32	5/16
5/8 X 18	7/8 X 14	0.87	3600-625T	5/8 X 18	53/64	7/8 X 14	1.00	0.88	5/8 X 18	25/32	5/16
3/4 X 10	1-1/8 X 12	1.12	3600-875T	3/4 X 10	1-1/16	1-1/8 X 12	1.31	1.14	3/4 X 10	31/32	5/16
3/4 X 16	1-1/8 X 12	1.12	3600-875T	3/4 X 16	1-1/16	1-1/8 X 12	1.31	1.14	3/4 X 16	31/32	5/16
7/8 X 9	1-1/4 X 12	1.25	3600-875T	7/8 X 9	1-3/16	1-1/4 X 12	1.44	1.27	7/8 X 9	1-3/32	5/16
7/8 X 14	1-1/4 X 12	1.25	3600-875T	7/8 X 14	1-3/16	1-1/4 X 12	1.44	1.27	7/8 X 14	1-3/32	5/16
1 X 8	1-3/8 X 12	1.37	3600-100T	1 X 8	1-5/16	1-3/8 X 12	1.56	1.39	1 X 8	1-7/32	5/16
1 X 12	1-3/8 X 12	1.37	3600-100T	1 X 12	1-5/16	1-3/8 X 12	1.56	1.39	1 X 12	1-7/32	5/16
1 X 14	1-3/8 X 12	1.37	3600-100T	1 X 14	1-5/16	1-3/8 X 12	1.56	1.39	1 X 14	1-7/32	5/16
1-1/8 X 7	1-1/2 X 12	1.62	3600-1.1/8HT	1-1/8 X 7	1-7/16	1-1/2 X 12	1.84	1.52	1-1/8 X 7	1-11/32	5/16
1-1/8 X 12	1-1/2 X 12	1.62	3600-1.1/8HT	1-1/8 X 12	1-7/16	1-1/2 X 12	1.84	1.52	1-1/8 X 12	1-11/32	5/16
1-1/4 X 7	1-5/8 X 12	1.81	3600-1.1/4HT	1-1/4 X 7	1-9/16	1-5/8 X 12	2.06	1.64	1-1/4 X 7	1-15/32	5/16
1-1/4 X 12	1-5/8 X 12	1.81	3600-1.1/4HT	1-1/4 X 12	1-9/16	1-5/8 X 12	2.06	1.64	1-1/4 X 12	1-15/32	5/16
1-1/2 X 6	1-7/8 X 12	2.00	3600-1.1/2HT	1-1/2 X 6	1-13/16	1-7/8 X 12	2.28	1.89	1-1/2 X 6	1-23/32	5/16
1-1/2 X 12	1-7/8 X 12	2.00	3600-1.1/2HT	1-1/2 X 12	1-13/16	1-7/8 X 12	2.28	1.89	1-1/2 X 12	1-23/32	5/16

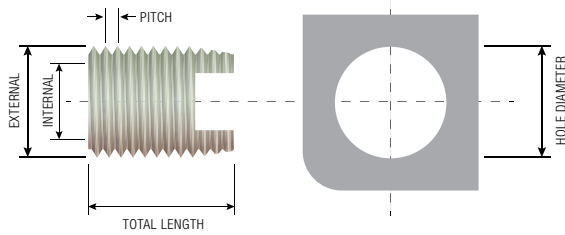

Tapserts are self cutting threaded inserts that feature both external and internal threads. They are driven into a pre-formed or pre-drilled retaining hole and the cutting slots (or cutting bores) effectively tap the hole as the insert is wound into the parent material.

Tapserts are ideal for use in low shear strength materials (such as alloys, plastics and castings) which require threaded seats with high load capacity and wear resistance.

Tapserts feature:

- High pull-out strength
- High loading capacity in low shear strength materials
- Wear free, vibration resistant screw joint
- Pre-cast or pre-drilled holes with standard tolerance
- No requirement for expensive thread tapping tools
- Retains and captures chips from installation in chipping reservoirs.

HOLE PREPARATION

The receiving hole is drilled or pre-cast in the parent material. Generally there is no requirement to countersink the hole but it is recommended care is taken not to warp the workpiece surface when installing the insert. Tapserts must be installed at least 0.1-0.2mm below the assembly surface.

- The length of the Tapsert MUST NOT exceed the thickness of the parent material.
- The minimum hole depth is indicated in the data tables included in every kit. Alternatively these may be downloaded from the website www.powercoil.com.au
- The minimum wall thickness of the assembly is dependant on the maximum insert loads and the elasticity of the parent material.
- Detailed hole diameter information is shown on the installation leaflet included with every kit and is also available at www.powercoil.com.au. As a general guide hard materials require a larger diameter hole than softer, elastic materials. If the installed insert is being subjected to high loads it is recommended to perform material specific testing prior to production.

INSTALLATION NUT & BOLT

Screw the insert onto the bolt and nut assembly ensuring the slot side is pointing downward. Thread the nut down the bolt until it sits firmly against the top of the Tapsert. Ensure that the Tapsert is perpendicular to the workpiece and apply downward pressure on the installation assembly. Turn the bolt head to wind the Tapsert into the receiving hole. The tapsert is installed when the nut is flush with the top of the parent material. Loosen the nut and wind the assembly out of the Tapsert. Complete instructions are included in every Tapsert kit.

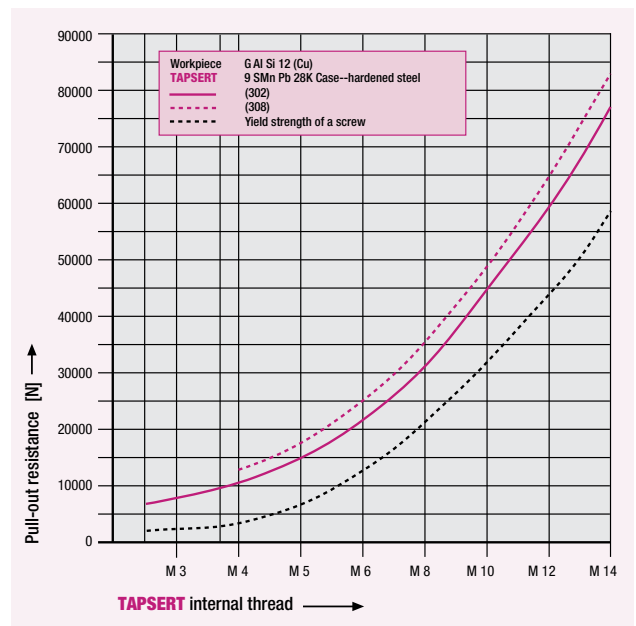
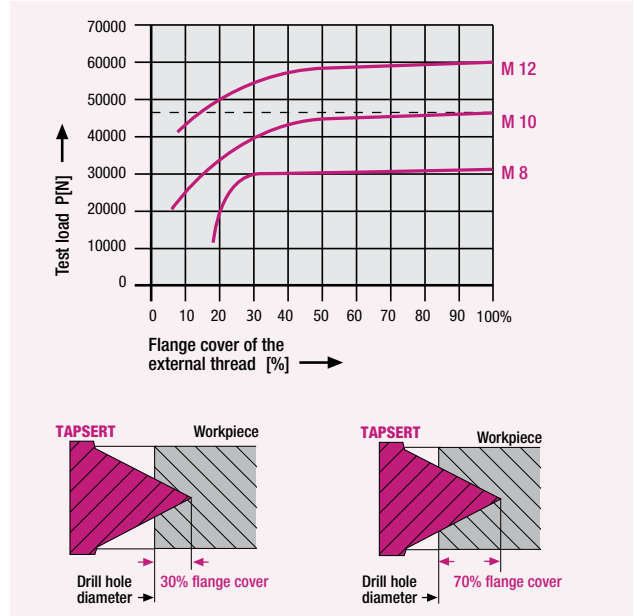

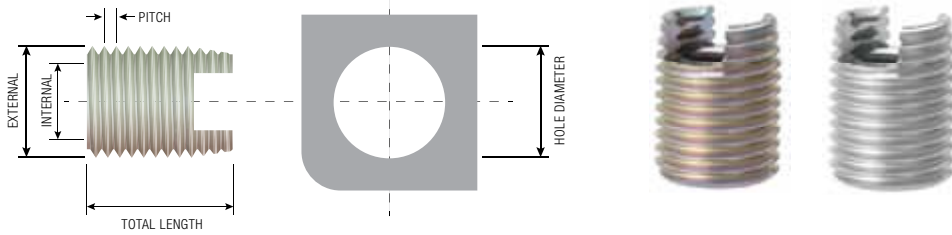

Light Alloys
Rm = tensile strength N/mm²

MS, Bronze, NF Metal
Cast Iron
HB = Brinell hardness N/mm²

		DRILL SIZE SELECTION				Minimum drill hole depth for blind holes	
		Rm < 250	Rm < 300	Rm < 350	Rm > 350		
				Rm > 350	Rm > 350		
				< 200 HB	> 200 HB		
INTERNAL THREAD	EXT. THREAD	LENGTH	MM	MM	MM	MM	MM
M 2.5 - 0.45	M 4.5 - 0.5	6	—	4.1	4.2	4.3	8
M 3.0 - 0.6	M 5 - 0.5	6	—	4.6	4.7	4.8	8
M 4 - 0.7	M 6.5 - 0.75	8	5.9	6.0	6.1	6.2	10
M 5 - 0.8	M 8 - 1.0	10	7.2	7.3	7.5	7.6	13
M 6 - 1.0	M 10 - 1.5	14	8.8	9.0	9.2	9.4	17
M 8 - 1.25	M 12 - 1.5	15	10.8	11.0	11.2	11.4	18
M 10 - 1.5	M 14 - 1.5	18	12.8	13.0	13.2	13.4	22
M 12 - 1.75	M 16 - 1.5	22	14.8	15.0	15.2	15.4	26
M 16 - 2.0	M 20 - 1.5	22	18.8	19.0	19.2	19.4	27
M 16 - 1.5	M 20 - 1.5	22	18.8	19.0	19.2	19.4	27
M 18 - 2.5	M 22 - 1.5	24	20.8	21.0	21.2	21.4	29
M 20 - 2.5	M 26 - 1.5	27	24.8	25.0	25.2	25.4	32
M 22 - 2.5	M 26 - 1.5	30	24.8	25.0	25.2	25.4	36
M 24 - 3.0	M 30 - 1.5	30	28.8	29.0	29.2	29.4	36
M 14 - 1.25 Spark Plug	M 18 - 1.5	15	16.8	17.0	17.2	17.4	28
M 14 - 1.25 Spark Plug	M 18 - 1.5	9	16.8	17.0	17.2	17.4	28
M 14 - 1.25 Spark Plug	M 18 - 1.5	9 & 15	16.8	17.0	17.2	17.4	28
UNC 1/4 - 20	M 10 - 1.5	14	8.8	9.0	9.2	9.4	17
UNC 5/16 - 18	M 12 - 1.5	15	10.8	11.0	11.2	11.4	18
UNC 3/8 - 16	M 14 - 1.5	18	12.8	13.0	13.2	13.4	22
UNC 7/16 - 14	M 16 - 1.5	22	14.8	15.0	15.2	15.4	26
UNC 1/2 - 13	M 18 - 1.5	22	16.8	17.0	17.2	17.4	28
UNC 5/8 - 11	M 20 - 1.5	22	18.8	19.0	19.2	19.4	27
UNF 1/4 - 28	M 10 - 1.5	14	8.8	9.0	9.2	9.4	17
UNF 5/16 - 24	M 12 - 1.5	15	10.8	11.0	11.2	11.4	18
UNF 3/8 - 24	M 14 - 1.5	18	12.8	13.0	13.2	13.4	22
UNF 7/16 - 20	M 16 - 1.5	22	14.8	15.0	15.2	15.4	26
UNF 1/2 - 20	M 18 - 1.5	22	16.8	17.0	17.2	17.4	28
UNF 5/8 - 18	M 20 - 1.5	22	18.8	19.0	19.2	19.4	27

DRILL HOLE DIAMETER

Brittle, tough, and hard materials require a larger drill hole than soft and elastic materials. For recommended hole sizes see table above. The drill sizes in bold are the recommended diameter for easy assembly. Smaller diameters may require the use of cutting fluid during installation. When specific load performance is required we advise insert/material testing.

INSTALLATION



1 Drill hole to recommended size as shown in the selection table.

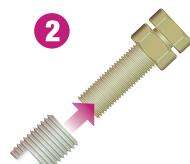

2 Thread the Tapsert on to the bolt ensuring the slot side is down. The insert should be flush with the end of the bolt.

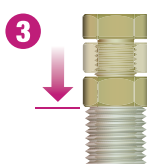

3 Thread the nut down the bolt until it sits firmly against the top of the Tapsert.

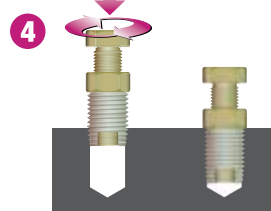

4 To ensure the Tapsert installation is straight apply downward pressure on the assembly.

If using an open ended wrench apply downward pressure to the bolt head whilst turning the nut to wind the Tapsert in. Alternatively if using a socket for installation apply downward pressure to the socket.

The Tapsert is installed when the nut is flush with the top of the parent material.

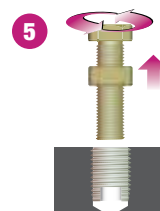

5 Loosen the nut with an open ended wrench and wind the nut and bolt assembly out of the Tapsert.

Congratulations – you have successfully created a new thread.



NOTE Tapping fluid should be used to aid installation.



Die aus nicht rostendem Chromnickelstahl hergestellten PowerCoil Gewinde Einsätze (Drahtgewindeeinsätze) sorgen für hochfeste interne Gewinde, die temperatur- und rostbeständig sind. Ihr einzigartiges Design garantiert überlegene Gewinde, deren Verbundfestigkeit durch keine andere Befestigungsmethode erreicht wird. Die Einsätze sind in zwei Grundausführungen – frei laufend oder mit Screwlocking- erhältlich, und sind viel leichter und preiswerter als entsprechende andere Gewindeeinsatztypen. Aufgrund ihrer kompakten Größe können sie normalerweise ohne weitere Vorkehrungen in bestehende Designs integriert werden.

FREE RUNNING (FREI LAUFEND)

Die aus präzisions-profilierem Austenitedelstahl hergestellten PowerCoil free running inserts (frei laufenden Einsätze) haben eine federartige Erscheinung. Wenn eingebaut – unter Einsatz beliebiger Hand- und automatischer Werkzeuge –, bilden sie stabile, dauerhafte interne Gewinde, die hitze- und rostbeständig sind. Nach dem Einpassen wird ihre Einbaulage durch Radialdruck zwischen den Windungen und den Seiten der Gewindebohrung fixiert. Dieser Druck kommt dadurch zustande, dass der freie Durchmesser der Einsätze um einen festgelegten Betrag größer als der installierte Durchmesser ist.

SCREW LOCKING (SCREWLOCKEND)

Screwlockende (oder selbstsichernde) Einsätze sind bei Anwendungen, die zyklischen Schwingungen oder Stoßwirkungen ausgesetzt sind, besonders vorteilhaft. Außer den Vorzügen der frei laufenden Einsätze bieten screwlockende Einsätze noch zusätzlich die selbstsichernde Screwlockung. Die Screwlockung wird dabei durch eine oder mehrere polygon geformte Windungen erzielt, die klemmend auf die Flanken der eingedrehten Schraube wirken. Jede dieser Windungen hat eine tangentiell verlaufende Sperrsehne, die in den inneren Durchmesser der normalen, frei laufenden Windungen hineinragt. Wenn das Bolzengewinde durch die Windungen geht, werden die Klemmflächen nach außen verdrängt und üben dann radialen oder Klemmdruck auf das Bolzengewinde aus. Wenn das Bolzengewinde entfernt wird, nehmen die Windungen wieder ihre ursprüngliche Form an und ermöglichen wiederholten Einsatz unter Beibehaltung eines messbaren Klemmdrucks. Hinweis: Es wird empfohlen, beim Einsatz von Schraubverschlusseinsätzen geschmierte oder eng anliegende, überzogene Bolzen oder Schrauben zu verwenden.

EIGENSCHAFTEN UND VORZÜGE

Jahrelang wurden spiralgewundene Drahtgewindeeinsätze als Reparaturmittel für beschädigte Gewinde beschrieben, und diese speziellen Verbindungen litten somit unter einem falschen Image.

Sie sind viel leichter und preiswerter als vergleichbare Gewindeeinsatztypen, und aufgrund ihrer Kompaktheit können sie normalerweise in existierende Designs integriert werden, auch wenn diese hierzu nicht vorgesehen waren. Im Gegensatz zu anderen Sparmaßnahmen führt ihr Einsatz zu Qualitäts- und Leistungsverbesserung bei gleichzeitiger Reduzierung der Gesamtproduktionskosten. Sie ermöglichen die Verwendung von kleineren Querschnitten oder leichteren Mutterwerkstoffen, ohne dass bei der Festigkeit der Gewinde Kompromisse eingegangen werden müssen. Sie schützen gebohrte Gewinde vor Defekten, die aufgrund von Abriss, Festfressen, Rost und Verschleiß auftreten. PowerCoil Gewinde Einsätze werden aus austenitischem Edeldraht hergestellt, der auf eine Zugfestigkeit von über 200 000psi und eine Härte von Rc43-50 verformungsgehärtet ist. Die Oberflächenbeschaffenheit der Einsätze ist ausgezeichnet, sodass durch Reibung verursachte Gewindekorrosion praktisch ausgeschlossen ist.

Das kontinuierliche Spiraldesign macht dicke Wandstrukturen zur Unterlegung der internen und externen Gewinde unnötig – die Drahtwindung mit rhombischem Profil IST das Gewinde. PowerCoil Gewinde Einsätze können in Naben oder Flanschen mit reduziertem Durchmesser und in engen Bauräumen installiert werden – sie sind Platz sparend und leicht, bei gleichzeitig hoher Festigkeit. Ein Nabenradius, der dem Nenndurchmesser des Bolzens entspricht, ist normalerweise ausreichend.

Ein vollständiges Sortiment von Einbauwerkzeugen für spezifische Produktionsmethoden ist erhältlich - Handeinbauwerkzeuge für kleine Lose und Reparaturen, sowie elektrische und pneumatische Werkzeuge für Loseproduktionserfordernisse.

FESTIGKEIT

Aufgrund ihrer Biegsamkeit erzeugen Drahtgewindeeinsätze im Vergleich mit herkömmlichen Gewindebohrungen interne Gewinde mit einer besseren Verteilung der Restanzugslast. Bei herkömmlichen Gewindebohrungen werden 70% der Scherkräfte von den ersten drei Windungen der Bohrung aufgenommen. Die Biegsamkeit der Drahtgewindeeinsätze hilft bei der Kompensation von Flanken- und Steigungswinkel Fehlern, die bei normalen Gewindebohrungen auftreten, und verbessert die Lasttragkraft durch Umwandeln der Restkräfte in eine Ringspannung, die in die Wand der Gewindebohrung abgeleitet wird. Das Design kann somit auf die Festigkeit der Bolzen bauen, auch wenn kleinere und kürzere Gewinde auf Leichtbauwerkstoffen verwendet

werden. Bei der Installation wird der Durchmesser der höher-festen Windungen eines Drahtgewindeeinsatzes reduziert. Die nach außen gerichtete Federspannung klemmt den Einsatz in Position. Jede Windung kann sich unabhängig biegen, um soviel Kontaktfläche wie möglich auf dem Ausgangsgewinde abzudecken. Sowohl statische wie dynamische Lasttragkräften werden hierdurch verbessert.

Standardbolzen

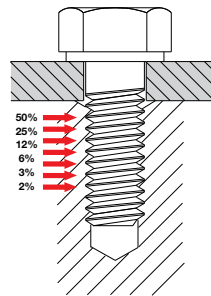

Bolzen mit PowerCoil Einsatz

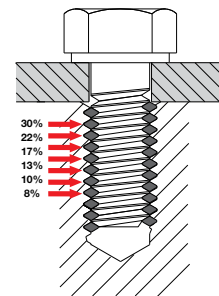

SPANNUNGSELIMINIERUNG

Das Ausgangsmaterial wird praktisch überhaupt nicht unter Spannung gesetzt, da kein Festmachen, Einrasten, Umformen oder Keilen nötig ist. Der Einsatz wird durch seine nach außen gerichtete Federaktion festgehalten.

VERSCHLEISSBESTÄNDIGKEIT

Dank der Kombination von Materialhärte und ausgezeichneter Oberflächenqualität der Drahtgewindeeinsätze werden interne Gewinde erzeugt, die den Verschleiß aufgrund von Gewindereibung praktisch ausschließen. Dies ist besonders bei Anwendungen, die wiederholten Ein- und Ausbau erfordern von unschätzbarem Wert. Der niedrige Reibungskoeffizient garantiert, dass praktisch das gesamte Drehmoment in Klemmkraft umgesetzt wird, und die Gewinde fest angezogen bleiben.

KORROSIONSSCHUTZ

Unter normalen Umgebungsbedingungen ist der in PowerCoil verwendete 18/8 austenitische Edeldraht rostbeständig. Das Auftreten galvanischer Vorgänge im Gewinde ist geringfügig, was die Lebensdauer des Befestigungssystems verlängert. Galvanische Korrosion ist die folgenschwerste Korrosionsart bei Einsätzen und Schraubverbindungen. Galvanische Korrosion ist eine Folge des Kontakts unterschiedlicher Metalle miteinander bei Vorhandensein einer elektrolytischen Lösung. Alle Metalle haben verschiedene Grade von "Reaktivität" und "Stabilität" und können in einer galvanischen Serie zunehmender Reaktivität aufgelistet werden. Gold und Platin sind die edelsten Metalle, während Zink und Magnesium am ehesten reagieren. Die am häufigsten vorkommende elektrolytische Lösung ist normales Wasser. Salzwasser ist aufgrund der hohen Konzentration gelöster Salze besonders korrodierend. Galvanische Korrosion kann am besten verhindert werden, indem Metalle ähnlichen Potentials zusammen verwendet werden und die elektrolytische Leitung eliminiert wird. Der reaktive Edelstahl der PowerCoil Gewinde Einsätze wird nicht passiviert, sodass bei deren Einsetzen in Aluminium- oder Magnesium-Mutterwerkstoffen das Risiko der galvanischen Korrosion wesentlich gemindert wird.

Einige zusätzliche Maßnahmen zur Reduzierung galvanischer Korrosion sind:

1. Die Verbindungen von elektrolytischer Lösung fernhalten. Dies kann durch Dichtungen oder Versiegeln erreicht werden.
2. Kadmierte Einsätze vorgeben. Der Kadmiumbelag bietet eine Rostschutzbarriere. Außerdem ist er schmierfähig, was beim Einsatz von Edelstahlschrauben eventuelles Festfressen abstellt.
3. Das Aufbringen korrosionshemmender Pasten oder Verbindungen, wie Zinkchromatgrundierung (MIL-P-8585) und Strontiumchromatgrundierung (MIL-P-23377). Hinweis: Direkt auf den Gewindeeinsatz aufgetragene Pasten können sich zwischen dem Draht und dem Gewinde festsetzen und die korrekte Toleranz beeinträchtigen. Es wird daher empfohlen, die Paste nur auf die Schraube und nicht auf das Gewinde aufzutragen. Wenn Zinkchromatgrundierung für die Gewindebohrung verwendet wird, sollte sie verdünnt und sparsam aufgetragen werden. Der Einsatz muss eingesetzt werden, bevor die Grundierung antrocknet.
4. Auf den Einsätzen ein Trockenschmiermittel vorgeben, z.B. Molybdänsulfid. Dies bildet eine zusätzliche Rostschutzbarriere.
5. Wenn möglich, und vorausgesetzt es beeinträchtigt die fertige Baugruppe nicht, sollte die externe Verbundfläche mit einer geeigneten Farbe gestrichen werden.

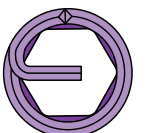
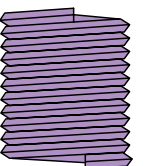
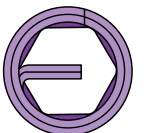
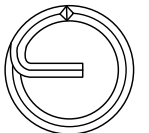
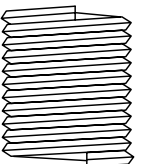
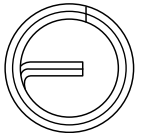

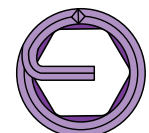
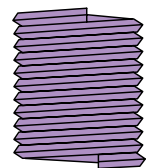
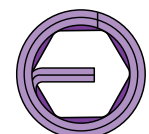
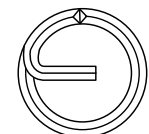
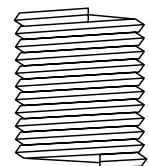
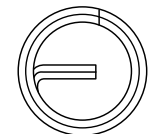

WERKSTOFFE

PowerCoil Standard Inserts (Standardeinsätze) sind aus 304 (18/8) austenitischem Edelstahl hergestellt, dessen Qualität gemäß DTD 734A als Flugzeugbauniveau zertifiziert ist. Alternative Werkstoffe sind unter anderem 316 Edelstahl und eine Reihe anwendungsspezifischer Beläge.

ALTERNATIVE WERKSTOFFE

Phosphorbronze

NE-Kupfer/Zinnlegierung gemäß BS2783 PB 102 EH – ist für den Betrieb im Temperaturbereich -200°C bis +300°C geeignet.

Inconel X-750

Hitzebeständige, härtbare Nickelbasislegierung (entsprechend Vorgaben SAE AS 7246, DIN/NF 3018, W.NR 2.4669, UNS N07750). Inconel X-750 ist für den Betrieb im Temperaturbereich -200°C bis +550°C geeignet.

Nimonic 90

Hitzebeständige, härtbare Nickelbasislegierung BS2 HR 501 (entsprechend der Vorgaben W.NR 2.4632, UNS N07090). Nimonic 90 ist für den Betrieb im Temperaturbereich -100°C bis +650°C geeignet.

Einsatz-material	Max. Temperatur		Typische Anwendungen	Belag
	Spitze	Dauernd		
Edelstahl 304	425°C	315°C	Meiste allgemeine Anwendungen in allen Werkstoffen	FL, AG, CD
	800°F	600°F		
Edelstahl 316	425°C	315°C	Erhöhte Rostbeständigkeit, für Anwendungen mit Salzwasser	FL, AG, CD
	800°F	600°F		
Phosphorbronze	300°C	235°C	Kupferanteile, nicht magnetisch, Anwendungen mit geringer Durchlässigkeit	AG, CD
	572°F	455°F		
Inconel X-750	650°C	550°C	Raumfahrt, Turbinen, korrosionsfördernde Umgebungen, hohe Temperaturen	AG
	1200°F	1020°F		
Nimonic 90	650°C	550°C	Raumfahrt - und Turbinen -anwendungen	AG
	1200°F	1020°F		

ALTERNATIVE OBERFLÄCHEN UND BELÄGE

Kadmiumbelag

Galvanisch aufgebracht Kadmium gemäß DTD 904/Def Stan 03-19 (entsprechend Vorgaben FED. QQ-P-416, LN 9368). Der Kadmiumbelag ist eine ausgezeichnete Barriere zwischen unähnlichen Metallen, galvanische Korrosion wird wesentlich reduziert, seine gute Schmiereigenschaften und ausgezeichnete Korrosionsbeständigkeit verhindert Festfressen und Verschleiß zwischen den Gewindeteilen. Kadmiumbelag ist für den Betrieb im Temperaturbereich -200°C bis +235°C geeignet

Kadmierte Teile dürfen nicht

- Temperaturen über 235°C (455°F) ausgesetzt werden
- mit Treibstoff oder Öl in Kontakt kommen
- mit Lebensmitteln oder Trinkwasser in Kontakt kommen
- mit Titan Komponenten verwendet werden (direkt oder indirekt). Bei erhöhten Temperaturen kann es zu Brüchigkeit mit nachfolgendem Versagen von Komponenten kommen.
- Kadmium ist hochgiftig – vorsichtig verfrachten, bearbeiten und installieren

Zinkbelag

Galvanisch aufgebracht Zink gemäß BS 3382. Galvanisch aufgebracht Zinkbeläge sind die in der Industrie am häufigsten verwendeten galvanisierten Oberflächen. Zink ist für den Betrieb im Temperaturbereich -200°C bis +250°C geeignet.

Silberbelag

Galvanisch aufgebracht Silber gemäß DTD 939. Silberbeläge verhindern Festfressen und Verschleiß zwischen den Gewindeteilen in hohen Temperaturen und werden hauptsächlich für Verbindungen in Luftfahrtmotoren verwendet. Silberbelag ist für den Betrieb im Temperaturbereich -200°C bis +650°C geeignet. Drahteinsätze mit Silberbelag können in verschiedene Werkstoffe eingesetzt werden, einschließlich Aluminiumlegierungen, Magnesiumlegierungen, korrosions- und hitzebeständige Werkstoffe, usw.

Drahteinsätze mit Silberbelag sollten nicht in Titanlegierungen eingesetzt werden, die eine Betriebstemperatur von 300°C (570°F) überschreiten. Spannungskorrosion kann als Folge der Kombination von Silber und Titan im Gehäusematerial auftreten.

Trockenschmiermittel

Heißgehärtetes Molybdänsulfid als Trockenschmierbelag gemäß MIL-L-0046010 ist ein Belag mit niedrigem Reibungskoeffizienten und ausgezeichneter Lasttragkraft. Trockenschmiermittel verhindert Festfressen und Verschleiß zwischen den Gewindeteilen und kommt besonders bei Anwendungen mit Gewindeeinsätzen mit Screwlockung zur Wirkung. Trockenschmiermittel ist für den Betrieb im Temperaturbereich -100°C bis +250°C geeignet.

Belag/Oberfläche	Teilnr.-Suffix	Geltende Prozess-Spezifikation
Silberbelag	AG	DTD 939
Kadmiumbelag	CD	QQP-416 oder DEF STD 03-19
Trockenschmiermittel	FL	MIL-L-8937 oder MIL-L-46010
Rote Farbe	–	Zur Kennung auf Screwlockungs-Einsätzen*

* andere Farben können ebenfalls zu Kennungszwecken verwendet werden

WAHL DER KORREKTEN EINSATZLÄNGE

PowerCoil Gewinde Einsätze sind in allen gängigen Gewindearten erhältlich. Es sind fünf Einsatzlängen pro Gewindegröße erhältlich. Die korrekte Einsatzlänge ist wichtig, um die Reißlast des Bolzens an die des Mutterwerkstoffs anzugleichen. Die fünf Einsatzlängen (empfohlene Gewindeaufnahme für den PowerCoil Drahtgewindeeinsatz), 1D, 1.5D, 2D, 2.5D und 3D sind in den grauen Spalten in der Tabelle unten zu sehen. Es handelt sich hierbei um berechnete Werte, da die Einsätze im nicht eingesetzten Zustand nicht gemessen werden können. Die Zahlen sind Vielfache der Gewindenenngröße oder –durchmesser des Einsatzes. Die tatsächlichen Einsatzlängen in der eingesetzten Position befinden sich in der Einsatzauswahltablelle. Sie sind dort als tatsächliche eingebaute Länge plus 1/2 Steigung angegeben. Mit der Tabelle unten kann eine Einsatzlänge gewählt werden, die eine Gewindeeinheit erzeugt, die so stabil ist, dass sie den Bolzen zerbricht, bevor das Muttermaterial oder der Einsatz beschädigt werden.

Empfohlene Einsatznennlängen basierend auf der Scherfestigkeit des Mutterwerkstoffs und der Festigkeit des Bolzenmaterials

UNIFIED (source BS7752 Part 1:1994)

Scherfestigkeit des Muttermaterials (KSI)	Bolzenmaterial – min. Zugfestigkeit vor Bruch (KSI)								
	54	75	96	108	125	132	160	180	220
10	2.0	2.5	3.0	3.0	–	–	–	–	–
15	1.5	1.5	2.0	2.5	2.5	3.0	–	–	–
20	1.0	1.5	1.5	2.0	2.0	2.0	2.5	3.0	3.0
25	1.0	1.0	1.5	1.5	1.5	2.0	2.0	2.5	2.5
30	1.0	1.0	1.0	1.5	1.5	1.5	2.0	2.0	2.5
40	1.0	1.0	1.0	1.0	1.0	1.5	1.5	1.5	2.0
50	1.0	1.0	1.0	1.0	1.0	1.0	1.0	1.5	1.5

BEISPIEL: Wenn die Scherfestigkeit des Mutterwerkstoffs 10KSI beträgt und die Zugfestigkeit des Bolzens 54 KSI, ist die korrekte Einsatzlänge 2,0 Durchmesser (2D).

METRISCH

Scherfestigkeit des Muttermaterials (MPa)	Bolzenmaterial – min. Zugfestigkeit vor Bruch (MPa)							
	300	400	500	600	800	1000	1200	1400
70	1.5	2.0	2.5	2.5	–	–	–	–
100	1.0	1.5	1.5	2.0	2.5	3.0	–	–
150	1.0	1.0	1.5	1.5	2.0	2.0	2.5	3.0
200	1.0	1.0	1.0	1.0	1.5	1.5	2.0	2.5
250	1.0	1.0	1.0	1.0	1.0	1.5	1.5	2.0
300	1.0	1.0	1.0	1.0	1.0	1.5	1.5	1.5
350	1.0	1.0	1.0	1.0	1.0	1.0	1.5	1.5

BEISPIEL: Wenn die Scherfestigkeit des Mutterwerkstoffs 150MPa beträgt und die Zugfestigkeit des Bolzens 600MPa, ist die korrekte Einsatzlänge 1,0 Durchmesser (1.5D).

BOLZEN

PowerCoil Gewinde Einsätze sind für den Einsatz mit allgemein erhältlichen Standardbolzen und –schrauben entworfen, die keine speziellen Komponenten erfordern.

Der Bolzen muss über die gesamte Einsetzlänge eingreifen, um maximale Festigkeit der Einheit zu erreichen. Um nur teilweises Eingreifen auszuschließen, empfiehlt es sich den Mitnehmerzapfen zu entfernen. Dies garantiert, dass die Klemmwindungen vollständig vom Gewinde des Bolzens aufgenommen werden. Wenn dies aufgrund von Designparametern nicht erfolgt, setzen Sie sich bitte mit PowerCoil in Verbindung.

HINWEISE:

1. Die angegebenen Bolzenzugkraftswerte sind Mindestwerte. Bei Wahl der Einsatzlänge, beachten Sie die in der Bolzenzeichnung oder den Beschaffungsangaben zulässigen Höchstwerte für die Zugkraft.
2. Betriebstemperaturen können zu wesentlichen Schwankungen der Werte führen. Kompensation sollte daher möglich sein.
3. Die Scherfestigkeit muss in Betracht gezogen werden, da der Mutterwerkstoff am größeren Durchmesser der gebohrten Gewinde Scherbelastung ausgesetzt ist.

- Wenn ein Wert zwischen zwei Werten in der Tabelle liegen, verwenden Sie den nächstniedrigeren Scherwert oder den nächsthöheren Zugkraftswert.
- Um optimale Festigkeit zu erreichen, müssen Bolzen- und Gewindelänge sowie die gesamte gebohrte Gewindetiefe lang genug sein, um das Eingreifen des Gewindes über die gesamte Einsatzlänge zu garantieren.

EINSÄTZE MIT SCREWLOCKING (SELBSTSICHERND)

PowerCoil Wire Screw Locking Inserts (screwlockende Einsätze) sind für Anwendungen entworfen, die zyklischen Schwingungen oder Stosswirkungen ausgesetzt sind. Die Einsätze mit Schraubklemmung wirken klemmend auf das eingedrehte Element und verhindern somit, dass dieses sich bei Schwingungen oder Stößen löst. Andere, teurere Klemmmechanismen werden damit überflüssig. Sie eignen sich hervorragend für "Einstellschrauben", indem sie die Bewegung eingedrehter Schrauben unterbinden.

FUNKTIONSWEISE DER SCREWLOCKEINSÄTZE

PowerCoil Wire Screw Locking Inserts bieten noch zusätzlich die selbstsichernde Screwlocking. Die Screwlocking wird dabei durch eine oder mehrere polygon geformte Windungen erzielt, die radialen Druck auf die eingedrehte Schraube ausüben. Jede dieser Windungen hat eine tangentiell verlaufende Klemmsehne, die in den inneren Durchmesser der normalen, frei laufenden Windungen hineinragt. Wenn das Bolzengewinde durch die Windungen geht, werden die Klemmflächen nach außen verdrängt und üben dann radialen oder Klemmdruck auf das Bolzengewinde aus. Wenn das Bolzengewinde entfernt wird, nehmen die Windungen wieder ihre ursprüngliche Form an und ermöglichen wiederholten Einsatz unter Beibehaltung eines messbaren Klemmdrucks.

Bitte beachten Sie: Es wird empfohlen nur geschmierte oder eng anliegende, überzogene Bolzen oder Schrauben mit PowerCoil Screwlockeinsätzen verwendet werden. Beim Einsatz mit wärmebehandelten, nicht belegten oder Edelstahlbolzen muss ein Mittel, das Festfressen verhindert, wie z.B. Molybdändisulfid verwendet werden, um fressenden Verschleiß weitgehend zu verhindern und optimale Nutzungsdauer zu garantieren. Die Nutzungsdauer kann auch durch Vorgabe von Trockenschmiermitteln und Kadmierung verbessert werden.

POSITION DER KLEMMWINDUNGEN

Für Längen von 1D, 1.5D, und 2D: Das Zentrum der Klemmwinding(en) befindet sich 1/2 x Anzahl der freilaufenden Windungen vom Mitnehmerzapfen.

Für Längen von 2.5D und 3D: Die Klemmwinding befindet sich um dieselbe Distanz vom Mitnehmerzapfen wie bei Einsätzen mit 2D Länge.

Screwlockende Einsätze sind rot gefärbt, um sie leichter kenntlich zu machen. Die Farbe ist alkohol-löslich und kann, wenn gewünscht, entfernt werden.

POWERCOIL WIRE SCREW LOCKING INSERTS (SCREWLOCKENDE EINSÄTZE) - DREHMOMENTWERTE

METRISCH STANDARD

Gewinde mm x mm	Drehmoment	
	Max (Nm)	Min (Nm)
M2.2x0.45	0.14	0.02
M2.5x0.45	0.23	0.05
M3.0x0.50	0.45	0.10
M3.5x0.60	0.68	0.12
M4.0x0.70	0.90	0.15
M5.0x0.80	1.60	0.30
M6.0x1.00	3.00	0.40
M7.0x1.00	4.50	0.60
M8.0x1.25	6.00	0.80
M10.0x1.50	10.50	1.40
M12.0x1.75	15.50	2.10
M14.0x2.00	23.50	3.00
M16.0x2.00	31.50	4.20
M18.0x2.50	42.00	5.50
M20.0x2.50	54.00	7.00
M22.0x2.50	67.50	9.00
M24.0x3.00	80.00	10.50
M27.0x3.00	94.00	12.00
M30.0x3.50	108.00	14.00
M33.0x3.50	122.00	15.50
M36.0x4.00	136.00	17.50
M39.0x4.00	150.00	19.50

METRISCH FEIN

Gewinde mm x mm	Drehmoment	
	Max (Nm)	Min (Nm)
M8.0x1.00	6.00	0.80
M10.0x1.00	10.50	1.40
M10.0x1.25	10.50	1.40
M12.0x1.25	15.50	2.10
M12.0x1.50	15.50	2.10
M14.0x1.50	23.50	3.00
M16.0x1.50	31.50	4.20
M18.0x1.50	42.00	5.50
M20.0x1.50	54.00	7.00
M22.0x1.50	67.50	9.00
M18.0x2.00	42.00	5.50
M20.0x2.00	54.00	7.00
M22.0x2.00	67.50	9.00
M24.0x2.00	80.00	10.50
M27.0x2.00	94.00	12.00
M30.0x2.00	108.00	14.00
M33.0x2.00	122.00	15.50
M36.0x2.00	136.00	17.50
M39.0x2.00	150.00	19.50
M36.0x3.00	136.00	17.50

Klemmdrehmomente gemäß MP3329, MP3330, MP3331

ROTE FÄRBUNG

PowerCoil Wire Screw Locking Inserts sind mit organischer roter Farbe gefärbt, um sie leichter kenntlich zu machen. Die Farbe beeinträchtigt den Einbau oder die Leistung des Einsatzes nicht und muss nicht entfernt werden (in den meisten Situationen). In Situationen, wo hohe Reinheit gefordert wird (wie bei der Montage von Präzisionsinstrumenten im Reinraum) kann der Farbelag vor der Installation durch Einweichen der Einsätze in Brennspiritus entfernt werden.

Hinweis: Es ist wichtig, dass der Bolzen alle Windungen des Einsatzes aufnimmt, um maximale Festigkeit zu erreichen.

PowerCoil Wire Screw Locking Inserts können Kundenerfordernissen gemäß entworfen werden. In bestimmten Fällen kann das Klemm-Drehmoment reduziert oder erhöht werden, je nach spezifischer Anwendung. Setzen Sie sich mit Ihrer PowerCoil-Vertretung in Verbindung, um Ihre spezifischen Erfordernisse zu diskutieren.

Bitte beachten: Für das Einsetzen von PowerCoil screwlockenden Einsätzen wird ein Vorspannpatronen-Werkzeug benötigt. Andere Installationsoptionen besprechen Sie bitte mit Ihrem PowerCoil-Vertreter.

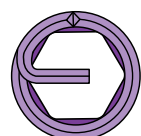
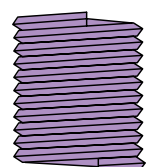
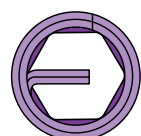
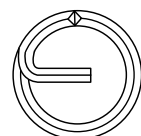
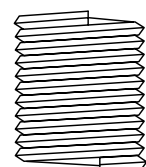
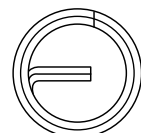

UNIFIED NATIONAL STANDARD – UNC

Gewinde inch x tpi	Drehmoment	
	Max (lb in)	Min (lb in)
2x56	1.25	0.19
3x48	2.00	0.44
4x40	3.00	0.63
5x40	4.69	0.81
6x32	6.00	1.00
8x32	9.00	1.50
10x24	13.00	2.00
12x24	24.00	3.00
1/4x20	30.00	4.50
5/16x18	60.00	7.50
3/8x18	80.00	12.00
7/16x14	100.00	16.50
1/2x13	150.00	24.00
9/16x12	200.00	30.00
5/8x11	300.00	40.00
3/4x10	400.00	60.00
7/8x9	600.00	82.00
1x8	800.00	110.00
11/8x7	900.00	137.00
11/4x7	1000.00	165.00
13/8x6	1150.00	185.00
11/2x6	1350.00	210.00

UNIFIED NATIONAL FEIN – UNF

Gewinde inch x tpi	Drehmoment	
	Max (lb in)	Min (lb in)
3x56	0.13	0.44
4x48	0.19	0.63
6x40	6.00	1.00
8x36	9.00	1.50
10x32	13.00	2.00
1/4x28	30.00	3.50
5/16x24	60.00	6.50
3/8x24	80.00	9.50
7/16x20	100.00	14.00
1/2x20	150.00	18.00
9/16x18	200.00	24.00
5/8x18	300.00	32.00
3/4x16	400.00	50.00
7/8x14	600.00	70.00
1x12	800.00	90.00
11/8x12	900.00	117.00
11/4x12	1000.00	143.00
13/8x12	1150.00	165.00
11/2x12	1350.00	190.00

Klemmdrehmomente gemäß NASM8846

Fabriqués à partir d'acier inoxydable chrome-nickel de qualité, les PowerCoil Wire Thread Inserts [filets rapportés PowerCoil] disposent de filets internes à haute résistance qui résistent aux effets causés par la température et la corrosion. Le design unique garantit des filets supérieurs dont la performance combinée ne peut être atteinte par aucune autre méthode de fixation simple. Disponibles sous deux formes de base, standard ou à frein de vis, ils sont plus légers et moins chers que tout autre type de filet rapporté équivalent et, grâce à leur petite taille, ils peuvent être généralement incorporés aux modèles existants qui ne disposent d'aucune dotation spécifique.

MODÈLE STANDARD

Fabriqués à partir de fil d'acier inoxydable austénitique enroulé en spirale hélicoïdale, les PowerCoil free running inserts [filets rapportés PowerCoil standard] ressemblent à des ressorts. Lorsqu'ils sont implantés, à l'aide de l'un des nombreux outils manuels ou automatiques, ils donnent des filets internes solides et permanents qui résistent à la chaleur et à la corrosion. Une fois ajustés, leur position est maintenue par l'action de la pression radiale qui s'exerce entre leurs spires et les flancs du trou taraudé. Cette pression existe parce que leur diamètre réel est plus large d'une valeur calculée que leur diamètre une fois implantés.

MODÈLE À FREIN DE VIS

Les filets rapportés à frein de vis (ou à couple permanent) sont extrêmement utiles pour les applications sujettes aux effets provoqués par les vibrations cycliques ou les chocs. En plus des avantages des filets rapportés standard, les PowerCoil screw locking inserts [filets rapportés PowerCoil à frein de vis] offrent une sécurité supplémentaire avec le couple de freinage permanent. Ceci est accompli par la pression radiale exercée sur le filetage extérieur par une ou plusieurs spires à déformation polygonale positionnées sur la longueur du filet rapporté. Chaque spire déformée consiste en un nombre de cordes tangentielles à frein qui dépassent à l'intérieur du diamètre mineur des spires normales. Tandis que le filetage extérieur passe à travers ces spires déformées, les vis à tête plate sont déplacées, exerçant ainsi une pression radiale ou couple permanent sur le filetage extérieur. Lorsque le filetage extérieur est retiré, les spires de freinage débloquent pour atteindre leur forme originale, permettant des assemblages répétés tout en conservant un niveau mesurable de couple permanent.

Remarque : il est recommandé que seuls des boulons ou vis lubrifiés ou à tête plate à ajustement serré soient utilisés avec les filets rapportés à frein de vis.

CHARACTÉRISTIQUES ET AVANTAGES

Pendant de nombreuses années, les filets rapportés à spires hélicoïdales ont été largement sous-estimés. L'idée qu'ils étaient destinés à la réparation des filets endommagés donna une fausse image à cette pièce de fixation unique.

Ils sont plus légers et moins chers que tout autre filet rapporté équivalent et, grâce à leur petite taille, ils peuvent généralement être introduits dans les modèles existants qui ne disposent d'aucune dotation spécifique. A la différence d'autres mesures économiques, leur introduction augmente la qualité et les performances tout en réduisant les coûts de production. Leur introduction peut aboutir à l'utilisation des sections plus fines ou de matériaux plus légers sans renoncer à la résistance des filets.

Ils protègent les filets taraudés contre le rayage, le grippage, la corrosion et l'usure. Les PowerCoil wire thread inserts [filets rapportés PowerCoil] sont fabriqués à partir de fil en acier inoxydable austénitique qui est durci jusqu'à une charge de rupture supérieure à 200 000 psi et une dureté de Rc43-50. Les filets rapportés bénéficient d'une finition de surface extrêmement lisse qui élimine virtuellement l'érosion du filet causée par le frottement.

Le modèle de spires hélicoïdales continues élimine le besoin d'avoir des structures à paroi épaisses pour soutenir les filets internes et externes : le ressort au profil de diamant EST le filet. Les PowerCoil wire thread inserts [filets rapportés PowerCoil] peuvent être implantés dans des bossages ou des flasques de petite taille et dans des zones comprimées, économisant ainsi de l'espace et du poids tout en fournissant une haute résistance. Un rayon de bossage égal au diamètre nominal du boulon est habituellement suffisant.

Une gamme complète d'outils d'installation est disponible pour s'adapter aux techniques particulières de production. une gamme d'outils manuels existe pour les petits travaux et réparations ; des outils électriques et pneumatiques sont disponibles pour les besoins de production de gros volume.

RÉSISTANCE

Grâce à leur flexibilité, les filets rapportés créent des filets internes qui ont une distribution améliorée de la charge de tension résiduelle en comparaison avec les trous taraudés conventionnels où jusqu'à 70% des forces de cisaillement sont soutenues par les trois premiers filets du trou taraudé. La flexibilité des filets rapportés aide à compenser les erreurs d'angle d'hélice et de flanc, inhérentes aux trous taraudés habituels, et améliore nettement la portance en empêchant la création de forces résiduelles dans un effort circonférentiel qui est dispersé dans la paroi du trou taraudé. Ceci permet au modèle de se baser en toute confiance sur

la résistance des boulons en utilisant des filets plus petits et plus courts même lorsqu'il est utilisé avec des matériaux de faible résistance. Les spires à haute résistance d'un filet rapporté subissent une réduction de diamètre pendant l'installation. La force de ressort externe des spires « bloque » le filet rapporté en place. Chaque spire peut se plier indépendamment pour entrer en contact avec la plus grande partie possible de la surface du filet du matériau récepteur. Les capacités de portance statique et dynamique sont améliorées.

Boulon standard

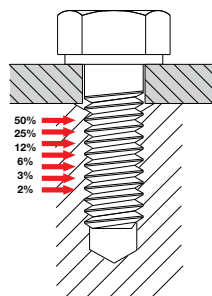

Boulon avec PowerCoil insert

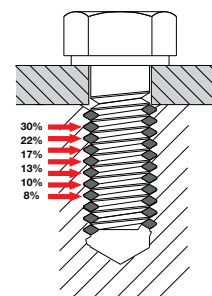

ELIMINER LA TENSION

Virtuellement, aucune tension ne s'introduit à l'intérieur du matériau récepteur parce qu'il n'y a pas d'agrafage, de verrouillage, de retraite ou d'accrochage en place. Le « jeu élastique » externe du filet rapporté le tient en place.

RÉSISTANCE À L'USURE

La combinaison de la dureté du matériau avec la surface brillante des filets rapportés crée des filets internes dans lesquels l'usure causée par le frottement des filets est virtuellement éliminée. Ceci est particulièrement utile pour les applications qui requièrent des montages et démontages répétés. Le faible coefficient de frottement garantit que l'ensemble du couple d'assemblage appliqué est virtuellement converti en charge de serrage. Donc, cela assure que les filets restent serrés.

PROTECTION CONTRE LA CORROSION

Le fil en acier inoxydable austénitique 18/8 utilisé pour les PowerCoil inserts [filets rapportés PowerCoil] résiste à la corrosion dans des conditions environnementales normales. L'action galvanique qui existe à l'intérieur de l'assemblage des filets est réduite, augmentant ainsi la durée de vie de l'assemblage de fixation.

La corrosion galvanique est la forme de corrosion la plus importante qui touche les filets rapportés et les pièces de fixation. La corrosion galvanique apparaît lorsque des métaux distincts sont en contact en présence d'une solution électrolytique. Tous les métaux déploient différents degrés d'« activité » ou de « noblesse » et peuvent être arrangés en une série galvanique d'activité grandissante. L'or et le platine sont les plus nobles tandis que le zinc et le magnésium sont les plus actifs. La solution électrolytique la plus souvent rencontrée est l'eau ordinaire. L'eau de mer ou la vapeur saline provoque bien plus de dégâts à cause des concentrations élevées de sel dissous.

La meilleure façon d'éviter la corrosion galvanique est d'utiliser des métaux potentiels similaires et d'éliminer l'électrolyte. L'acier inoxydable actif des PowerCoil wire thread inserts [filets rapportés PowerCoil] n'est pas passivé. Ceci minimise la possibilité d'apparition de la corrosion galvanique qui apparaît lorsqu'ils sont implantés dans des matériaux récepteurs en aluminium ou magnésium. Les précautions supplémentaires à prendre pour réduire la corrosion galvanique sont :

1. Isoler les pièces de fixation de l'électrolyte. Ceci peut être réalisé à l'aide de joints et de dispositifs d'étanchéité.
2. Stipuler des filets rapportés cadmiés. Le dépôt de cadmium fournit une barrière sacrificielle contre la corrosion. De plus, le dépôt de cadmium a des propriétés lubrifiantes qui minimisent le grippage lorsque des vis en acier inoxydable sont utilisées.
3. Appliquer de la pâte ou un mélange inhibiteur de corrosion sur la vis. Ceux-ci incluent la primaire au chromate de zinc (MIL-P-8585) et la primaire au chromate de strontium (MIL-P-23377). Remarque : la pâte appliquée sur le filet rapporté PowerCoil Thread peut se retrouver enfermée entre le fil et le trou et causer une perte de tolérance appropriée. Il est donc recommandé de n'appliquer la pâte que sur la vis et non sur le filet rapporté. Si une primaire au chromate de zinc est appliquée sur le trou taraudé, elle doit être diluée et appliquée avec parcimonie. Le filet rapporté doit être implanté lorsque la primaire est encore humide.
4. Stipuler l'application d'un film de lubrifiant hydrofuge tel que le bisulfure de molybdène sur les filets rapportés. Celui-ci fournira une seconde barrière pour lutter contre la corrosion.
5. Si cela est possible ou si cela ne perturbe pas l'assemblage terminé, le joint externe doit être revêtu d'une peinture appropriée.

MATÉRIAUX

Les PowerCoil standard inserts [filets rapportés standard PowerCoil] sont fabriqués à partir d'acier inoxydable austénitique 304 (18/8), pleinement certifié et de qualité pour avions, conformément au DTD 734A. Des matériaux alternatifs sont l'acier inoxydable 316 et une variété de revêtements spécifiques à l'application.

MATÉRIAUX ALTERNATIFS

Bronze de phosphore

Un alliage en cuivre / étain non ferreux, conformément au BS2783 PB 102 EH, est approprié pour un fonctionnement à des températures allant de -200°C à +300°C.

Inconel X-750

Alliage à base de nickel durci par précipitation et résistant aux températures élevées (spécifications équivalentes SAE AS 7246, DIN/FR 3018, W.NR 2.4669, UNS N07750). L'Inconel X-750 est approprié pour le fonctionnement à des températures allant de -200°C à +550° degrés celsius.

Nimonic 90

Alliage à base de nickel durci par précipitation et résistant aux températures élevées conformément au BS2 HR 501 (spécifications équivalentes W.NR 2.4632, UNS N07090). Le Nimonic 90 est approprié pour le fonctionnement à des températures allant de -100°C à +650° degrés celsius.

Matière du filet	Température max en pointe	Température continue	Applications classiques	Revêtements
Acier inoxydable 304	425°C 800°F	315°C 600°F	La plupart des applications FL, AG, CD générales avec tous les matériaux	FL, AG, CD
Acier inoxydable 316	425°C 800°F	315°C 600°F	Meilleure résistance à la corrosion pour les applications en eau de mer	FL, AG, CD
Bronze de phosphore	300°C 572°F	235°C 455°F	Pièces en cuivre, applications AG, CD non magnétiques et à faible perméabilité	AG
Inconel X-750	650°C 1200°F	550°C 1020°F	Aéronautique, propulseurs, environnements corrosifs, températures élevées	AG
Nimonic 90	650°C 1200°F	550°C 1020°F	Applications dans l'aéronautique et pour les propulseurs	AG

APPRÊTS ET REVÊTEMENTS ALTERNATIFS

Plaque de cadmium

Cadmium déposé par voie galvanique conformément au DTD 904/Def Stan 03-19 (spécifications équivalentes à FED. QQ-P-416, LN 9368). Le plaquage au cadmium fournit une excellente barrière entre les métaux distincts qui réduit de manière dramatique les effets de la corrosion galvanique, sa haute onctuosité et son excellente résistance à la corrosion prévient les grippages entre les composants filetés. La plaque de cadmium est appropriée pour l'opération à des températures allant de -200°C à +235°C.

Les pièces plaquées au cadmium de doivent pas

- être soumises à des températures supérieures à 235°C (455°F)
- entrer en contact avec du combustible ou de l'huile chaude
- entrer en contact avec de la nourriture ou de l'eau potable
- être utilisées avec des composants en titane (directement ou indirectement). A des températures élevées, une fragilisation et les dommages qui en résultent peuvent apparaître.
- Le cadmium est hautement toxique ; en conséquence, une attention particulière doit être observée durant le transport, la manipulation et l'installation.

Plaque de zinc

Zinc déposé par voie galvanique conformément au BS 3382. Le zinc déposé par voie galvanique est l'apprêt le plus largement utilisé dans l'industrie. Le zinc est approprié pour l'opération à des températures allant de -200°C à +250°C.

Plaque en argent

Argent déposé par voie galvanique conformément au DTD 939. Le plaquage en argent est utilisé afin de prévenir le grippage entre les composants filetés qui peut apparaître lors d'applications à des températures élevées et il est plus largement appliqué aux pièces de fixation des moteurs d'avion. La plaque en argent est appropriée pour l'opération à des températures allant de -200°C à +650°C. Les filets rapportés plaqués à l'argent peuvent être implantés dans divers matériaux comme les alliages d'aluminium, les alliages de magnésium, les matériaux résistants à la corrosion et aux températures élevées, etc.

Les filets rapportés plaqués à l'argent ne sont pas recommandés pour l'installation dans des alliages de titane qui pourraient servir à des

températures excédant 300°C (570°F). La corrosion sous contrainte, résultat de la combinaison entre l'argent et le titane, peut apparaître dans le matériau des boîtiers.

Film de lubrifiant hydrofuge

Un revêtement de film solide de lubrifiant hydrofuge de bisulfure de molybdène vulcanisé à chaud, conformément au MIL-L-0046010, fournit un revêtement avec un faible coefficient frictionnel avec d'excellentes capacités de portance. Le film de lubrifiant hydrofuge prévient contre le grippage entre les composants filetés et est particulièrement efficace dans les applications de filets rapportés à frein de vis. Le film de lubrifiant hydrofuge est approprié pour l'opération à des températures allant de -100°C à +250°C.

Plaquage/Apprêt	Suffixe du nr. de pièce	Spécification de procès applicable
Plaque en argent	AG	DTD 939
Plaque de cadmium	CD	QQP-416 ou DEF STD 03-19
Film de lubrifiant hydrofuge	FL	MIL-L-8937 ou MIL-L-46010
Colorant rouge	-	Appliqué pour les filets rapportés à frein à des fins d'identification*

* des colorants d'une autre couleur peuvent être utilisés à des fins d'identification particulière

SÉLECTION DE LA LONGUEUR CORRECTE DU FILET RAPPORTÉ

Les PowerCoil wire thread inserts [filets rapportés PowerCoil] sont disponibles pour tous les types de filets classiques. Cinq longueurs de filets rapportés sont disponibles pour chaque taille de filet. Il est important de sélectionner la longueur correcte de filet rapporté afin d'équilibrer la charge de rupture du boulon et la résistance au cisaillement du matériau récepteur. Les cinq longueurs de filet rapporté (prise de filet recommandée pour le PowerCoil wire thread insert [filet rapporté PowerCoil]), 1D, 1.5D, 2D, 2.5D et 3D sont indiquées dans la zone ombragée du tableau ci-dessous. Ce sont des nombres calculés puisque les filets rapportés ne peuvent pas être mesurés à l'état libre (non implantés). Les nombres sont des multiples de la dimension nominale du filet, ou du diamètre, du filet rapporté. Les longueurs actuelles de filet rapporté qui se trouvent dans la position d'installation sont énumérées dans les tableaux de sélection des filets rapportés. Elles représentent la longueur réelle lorsqu'ils ont implantés, plus 1/2 pas. A l'aide du tableau ci-dessous, une longueur de filet rapporté peut être sélectionnée afin de produire un système fileté suffisamment résistant pour fracturer un boulon avant qu'il ne raye ou n'endommage le matériau récepteur ou le filet rapporté.

Longueurs nominales recommandées de filet rapporté basées sur les forces du matériau récepteur versus celles du matériau du boulon

UNIFIE (source BS7752 Part 1:1994)

Force de cisaillement du matériau récepteur (KSI)	Charge de rupture (KSI) ultime minimale du matériau du boulon									
	54	75	96	108	125	132	160	180	220	220
10	2.0	2.5	3.0	3.0	-	-	-	-	-	-
15	1.5	1.5	2.0	2.5	2.5	3.0	-	-	-	-
20	1.0	1.5	1.5	2.0	2.0	2.0	2.5	3.0	3.0	-
25	1.0	1.0	1.5	1.5	1.5	2.0	2.0	2.5	2.5	-
30	1.0	1.0	1.0	1.5	1.5	1.5	2.0	2.0	2.5	-
40	1.0	1.0	1.0	1.0	1.0	1.5	1.5	1.5	2.0	-
50	1.0	1.0	1.0	1.0	1.0	1.0	1.0	1.0	1.5	1.5

EXEMPLE : Si la force de cisaillement du matériau récepteur est de 10KSI et la charge de rupture du boulon est de 54 KSI, la longueur correcte du filet rapporté est de 2.0 diamètre (2D).

METRIQUE

Force de cisaillement du matériau récepteur (MPa)	Charge de rupture (Mpa) ultime minimale du matériau du boulon							
	300	400	500	600	800	1000	1200	1400
70	1.5	2.0	2.5	2.5	-	-	-	-
100	1.0	1.5	1.5	2.0	2.5	3.0	-	-
150	1.0	1.0	1.5	1.5	2.0	2.0	2.5	3.0
200	1.0	1.0	1.0	1.0	1.5	1.5	2.0	2.5
250	1.0	1.0	1.0	1.0	1.0	1.5	1.5	2.0
300	1.0	1.0	1.0	1.0	1.0	1.5	1.5	1.5
350	1.0	1.0	1.0	1.0	1.0	1.0	1.5	1.5

EXEMPLE : Si la force de cisaillement du matériau récepteur est de 150Mpa et la charge de rupture du boulon est de 600Mpa, la longueur correcte du filet rapporté est de 1.5 diamètre (1.5D).

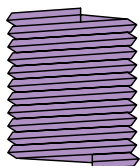
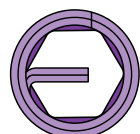
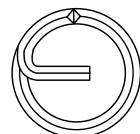
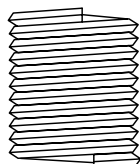
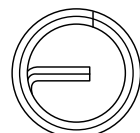

PRÉVISION DU BOULON

Les PowerCoil wire thread inserts [filets rapportés PowerCoil] sont conçus pour être utilisés avec des boulons et des vis standard et facilement accessibles qui ne requièrent pas de matériel spécial.

Le boulon doit s'engager sur toute la longueur du filet rapporté pour atteindre la résistance maximale de l'assemblage. Afin d'éviter un engagement partiel, il est recommandé que le tenon soit toujours retiré. Cela garantira également que la (les) spire(s) de freinage sera (seront) engagée(s) par les filets complets du boulon. Si les paramètres de design empêchent ceci, contactez PowerCoil pour demander assistance.

REMARQUES :

1. Les charges de rupture du boulon spécifiées sont les charges minimales. Lorsque vous choisissez une longueur de filet rapporté, vous devez prendre en considération la charge de rupture maximale permise par le schéma du boulon ou la spécification d'approvisionnement.
2. Les températures de service peuvent causer des variations significatives des valeurs de la charge, en conséquence une marge doit être permise.
3. L'importance des valeurs de cisaillement ne doit pas être perdue de vue parce que le matériau récepteur est enclin à subir une contrainte de cisaillement à proximité du diamètre majeur des filets taraudés.
4. Lorsque les valeurs des charges se trouvent entre deux valeurs parmi celles qui sont indiquées dans les tableaux, utilisez la valeur inférieure de cisaillement du matériau la plus proche, ou la valeur supérieure de charge de rupture du boulon la plus proche.
5. Pour atteindre la résistance maximale, la longueur du boulon et celle du filet, de même que la profondeur du filet taraudé, doivent être suffisantes pour assurer un engagement complet du filet sur toute la longueur du filet rapporté.

FILETS RAPPORTÉS À FREIN DE VIS (COUPLE PERMANENT)

Les Screw Locking PowerCoil wire thread inserts [filets rapportés PowerCoil à frein de vis] sont conçus pour les applications sujettes aux effets causés par les vibrations cycliques ou par les impacts. Le filet rapporté à frein de vis exerce une couple permanent sur les pièces de fixation avec un filet extérieur afin d'éviter le desserrage dû aux vibrations ou aux impacts. Ils éliminent le besoin d'utiliser d'autres mécanismes de fixation moins désirables et plus chers. Ils sont excellents lorsqu'ils sont utilisés dans des applications de « vis de réglage » évitant ainsi le fluage de la pièce de fixation mâle.

FONCTIONNEMENT DES FILETS RAPPORTÉS À FREIN DE VIS

Les PowerCoil Screw Locking inserts [filets rapportés PowerCoil à frein de vis] offrent une sécurité supplémentaire avec le couple de freinage permanent. Ceci est accompli par la pression radiale exercée sur le filetage extérieur par une ou plusieurs spires à déformation polygonale positionnées sur la longueur du filet rapporté. Chaque spire déformée consiste en un nombre de cordes tangentielles à frein qui dépassent à

l'intérieur du diamètre mineur des spires normales. Tandis que le filetage extérieur passe à travers ces spires déformées, les vis de freinage à tête plate sont déplacées et exercent une pression radiale (couple permanent) sur le filetage extérieur.

Lorsque le filetage extérieur est retiré, les spires de freinage débandent pour atteindre leur forme originale, permettant des assemblages répétés tout en conservant un niveau mesurable de couple permanent.

Veillez noter :

Il est recommandé d'utiliser uniquement des boulons ou vis lubrifiés ou à tête plate à ajustement serré avec les screw locking PowerCoil wire thread inserts [filets rapportés PowerCoil à frein de vis]. Si des boulons en acier inoxydable ou non métallisés traités thermiquement sont utilisés, un lubrifiant antigrippage, par exemple du bisulfure de molybdène, doit être utilisé afin de minimiser le grippage et assurer une durée de vie maximale. La durée de vie par résistance à l'usure des vis ou des boulons qui utilisent les PowerCoil screw locking wire thread inserts [filets rapportés à frein de vis PowerCoil] peut être augmentée grâce à un lubrifiant hydrofuge ou un plaquage de cadmium.

EMPLACEMENT DES SPIRES DE FREINAGE

Pour les longueurs de diamètre 1D, 1.5D et 2D : Le centre de la spire de freinage (ou des spires) est égal à 1/2 du nombre des spires libres. Pour les longueurs de diamètre 2.5D et 3D : La spire de freinage est située à la même distance du tenon que les filets rapportés de longueur 2D.

Les filets rapportés à frein de vis sont colorés en rouge à des fins d'identification uniquement. Le colorant est soluble dans l'alcool et peut être éliminé si nécessaire.

REVÊTEMENT DE TEINTURE ROUGE

Les PowerCoil screw locking inserts [filets rapportés PowerCoil à frein de vis] ont généralement un code couleur à l'aide d'un colorant organique à des fins d'identification. Le colorant n'affecte en aucune manière l'installation ou les performances du filet rapporté et il n'est pas nécessaire de l'éliminer (dans la majorité des situations). Dans les situations qui nécessitent une propreté extrême (comme l'assemblage d'instruments de précision dans une pièce propre), le colorant peut être éliminé en immergeant les filets rapportés dans une solution d'alcool dénaturé avant d'être implantés.

Les PowerCoil screw locking inserts [filets rapportés à frein de vis PowerCoil] peuvent être conçus pour répondre aux besoins particuliers du client. Dans certains cas et applications, le couple permanent peut être affaibli ou renforcé afin répondre aux nécessités d'une application spécifique. Dans ces situations, veuillez contacter votre représentant PowerCoil pour discuter de vos besoins particuliers.

Veillez noter : L'installation des PowerCoil screw locking inserts [filets rapportés à frein de vis PowerCoil] exige l'utilisation d'un outil de pré-enroulage. Veuillez discuter d'autres options d'installation avec votre agent PowerCoil.

VALEURS DE COUPLE DU POWERCOIL LOCKING INSERT [FILET RAPPORTÉ POWERCOIL]

METRIQUE A PAS NORMAUX			METRIQUE A PAS FINS			UNIFIED NATIONAL STANDARD - UNC			UNIFIED NATIONAL FEIN - UNF		
Filet	Couple Max (Nm)	Couple Min (Nm)	Filet	Couple Max (Nm)	Couple Min (Nm)	Filet	Couple Max (livre par pouce)	Couple Min (livre par pouce)	Filet	Couple Max (livre par pouce)	Couple Min (livre par pouce)
mm x mm			mm x mm			pouce x tpi			pouce x tpi		
M2.2x0.45	0.14	0.02	M8.0x1.00	6.00	0.80	2x56	1.25	0.19	3x56	0.13	0.44
M2.5x0.45	0.23	0.05	M10.0x1.00	10.50	1.40	3x48	2.00	0.44	4x48	0.19	0.63
M3.0x0.50	0.45	0.10	M10.0x1.25	10.50	1.40	4x40	3.00	0.63	6x40	6.00	1.00
M3.5x0.60	0.68	0.12	M12.0x1.25	15.50	2.10	5x40	4.69	0.81	8x36	9.00	1.50
M4.0x0.70	0.90	0.15	M12.0x1.50	15.50	2.10	6x32	6.00	1.00	10x32	13.00	2.00
M5.0x0.80	1.60	0.30	M14.0x1.50	23.50	3.00	8x32	9.00	1.50	1/4x28	30.00	3.50
M6.0x1.00	3.00	0.40	M16.0x1.50	31.50	4.20	10x24	13.00	2.00	5/16x24	60.00	6.50
M7.0x1.00	4.50	0.60	M18.0x1.50	42.00	5.50	12x24	24.00	3.00	3/8x24	80.00	9.50
M8.0x1.25	6.00	0.80	M20.0x1.50	54.00	7.00	1/4x20	30.00	4.50	7/16x20	100.00	14.00
M10.0x1.50	10.50	1.40	M22.0x1.50	67.50	9.00	5/16x18	60.00	7.50	1/2x20	150.00	18.00
M12.0x1.75	15.50	2.10	M18.0x2.00	42.00	5.50	3/8x18	80.00	12.00	9/16x18	200.00	24.00
M14.0x2.00	23.50	3.00	M20.0x2.00	54.00	7.00	7/16x14	100.00	16.50	5/8x18	300.00	32.00
M16.0x2.00	31.50	4.20	M22.0x2.00	67.50	9.00	1/2x13	150.00	24.00	3/4x16	400.00	50.00
M18.0x2.50	42.00	5.50	M24.0x2.00	80.00	10.50	9/16x12	200.00	30.00	7/8x14	600.00	70.00
M20.0x2.50	54.00	7.00	M27.0x2.00	94.00	12.00	5/8x11	300.00	40.00	1x12	800.00	90.00
M22.0x2.50	67.50	9.00	M30.0x2.00	108.00	14.00	3/4x10	400.00	60.00	11/8x12	900.00	117.00
M24.0x3.00	80.00	10.50	M33.0x2.00	122.00	15.50	7/8x9	600.00	82.00	11/4x12	1000.00	143.00
M27.0x3.00	94.00	12.00	M36.0x2.00	136.00	17.50	1x8	800.00	110.00	13/8x12	1150.00	165.00
M30.0x3.50	108.00	14.00	M39.0x2.00	150.00	19.50	11/8x7	900.00	137.00	11/2x12	1350.00	190.00
M33.0x3.50	122.00	15.50	M36.0x3.00	136.00	17.50	11/4x7	1000.00	165.00			
M36.0x4.00	136.00	17.50	Valeurs du couple de freinage en conformité avec MP3329, MP3330, MP3331			13/8x6	1150.00	185.00	Valeurs du couple de freinage en conformité avec NASM8846		
M39.0x4.00	150.00	19.50				11/2x6	1350.00	210.00			

Fabricados en acero inoxidable al cromo níquel de alta calidad, los insertos para reparación de roscas Power Coil proporcionan alta resistencia a las roscas internas lo que da como resultado una alta resistencia a la temperatura y a la corrosión. Su diseño único asegura roscas superiores cuyo comportamiento no puede ser igualado por ningún otro método de seguridad. Se encuentran disponibles en dos presentaciones básicas, standard y de seguridad, son mucho más ligeros y menos costosos que cualquier otro tipo de inserto equivalente y dado su tamaño compacto pueden generalmente incorporarse a diseños existentes en donde no se haya hecho preparación previa.

INSERTOS STANDARD

Fabricados a partir de un alambre de acero inoxidable austenítico, perfilado de precisión austenítico en forma de espiral helicoidal, los insertos standard Power Coil tienen forma de muelle. Cuando se instalan utilizando cualquiera de las herramientas, ya sean manuales o automáticas, proporcionan roscas internas resistentes y permanentes que soportan el calor y la corrosión. Una vez instaladas su posición se mantiene por la acción de presión radial entre las roscas y las ranuras del agujero roscado. Esta presión existe porque su diámetro libre es ligeramente superior al instalado en una pequeña proporción previamente calculada.

INSERTOS DE SEGURIDAD

El inserto de seguridad (o de cierre efectivo) están especialmente indicados en aplicaciones sujetas a efectos de vibración cíclica o impactos. Además de las ventajas proporcionadas por los insertos standard, los insertos de seguridad Power Coil ofrecen una seguridad adicional por su auto freno interno que lo hace más efectivo. Esto se consigue gracias a la acción de uno o varios cierres poligonales de las roscas del inserto posicionados a lo largo del mismo, que ejercen presión radial en los flancos de la rosca. En cada vuelta de agarre la rosca de seguridad consta de un número tangencial de roscas que empujan dentro del diámetro menor de la rosca standard. En la medida en que la rosca pasa a través de estas roscas de seguridad, los dispositivos se expanden aplicando presión radial o freno efectivo en la rosca del tornillo. Al retirar el tornillo roscado, las roscas de seguridad relajan su expansión a su forma original permitiendo repetir el roscado del tornillo y manteniendo su nivel de presión radial de seguridad.

Nota, se recomienda que solamente se utilicen tornillos niquelados o bien lubricados, con los insertos de seguridad.

CARACTERISTICAS Y BENEFICIOS

Durante muchos años, los insertos helicoidales han sido subestimados. El concepto popular de ser diseñados para reparar roscas dañadas ha dado a éste sistema único, esta falsa imagen.

Son mucho más ligeros y menos costosos que cualquier otro tipo equivalente de inserto

de rosca, y por su tamaño compacto, pueden generalmente introducirse en diseños preexistentes en donde no exista una preparación previa. Además de otros beneficios económicos, su utilización incrementa la calidad y rendimiento mientras reduce el costo total del producto. Su utilización es efectiva al utilizar materiales más delgados o más ligeros sin sacrificar la dureza de la rosca.

Los insertos protegen las roscas originales contra posibles fallos de pérdida de hilos, pérdida de medida, corrosión o desgaste. Los insertos Power Coil están fabricados con cable de acero inoxidable austenítico, que le permite trabajar con una fuerza a la tensión de 200,000 psi y una dureza de RC 43-50. Los insertos tienen un acabado superficial tan fino que prácticamente elimina la fricción que induce al posible desgaste.

El diseño helicoidal no requiere de paredes gruesas para soportar las roscas internas y externas y la rosca esta perfilada con diamante. Los insertos Power Coil pueden instalarse en secciones reducidas de bordes, flancos y dentro de áreas pequeñas – salvando espacio y peso mientras proporcionan alta resistencia.

El radio de una superficie que es igual al diámetro nominal del tornillo es normalmente suficiente.

Una amplia gama de herramientas de instalación se encuentra disponible para adaptarse a diferentes técnicas de producción. Existe una gama de herramientas manuales para pequeñas reparaciones; y las herramientas eléctricas y neumáticas están disponibles para altas producciones generalmente.

RESISTENCIA

Debido a su flexibilidad, los insertos conforman roscas internas que cuentan con una mucho mejor distribución de carga residuales comparados con agujeros roscados convencionales, en donde un porcentaje superior al 70% de las fuerzas cortantes son llevadas a cabo por las tres primeras roscas en el agujero roscado. La flexibilidad de los insertos ayudan a compensar los errores del paso y del ángulo de flancos inherentes a los agujeros normales roscados, y mejora significativamente la capacidad de carga por deflexión de fuerzas residuales dentro de la rosca en donde la presión se dispersa hacia las paredes del agujero roscado. Esto hace que el diseño sea muy flexible y de gran resistencia utilizando roscas más pequeñas y más cortas aun cuando los insertos sean usados en materiales menos resistentes.

Los insertos Power Coil de alta flexibilidad reducen su diámetro durante la instalación.

La fuerza del inserto al expandirse en el agujero asegura el inserto en su lugar correcto. Cada filete puede flexionarse independientemente para ponerse en contacto con la mayor cantidad de material de la superficie de la rosca. Ambas capacidades de carga, estática y dinámica son mejoradas.

Tornillo Standard

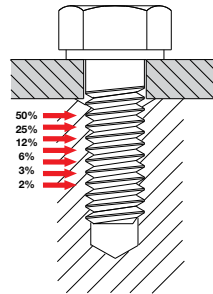

Tornillo Con Inserto PowerCoil

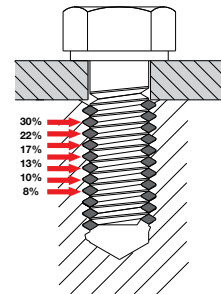

ELIMINA TENSIONES

Virtualmente ninguna tensión es introducida al material porque no hay sistema de sujeción, amarre, bloqueo, etc. en el lugar, sino que la acción de muelle del inserto lo mantiene en su lugar.

RESISTENCIA AL DESCASTE

La combinación de la dureza en el material y el acabado brillante de los insertos configuran roscas internas, en las que el desgaste de la rosca ocasionada por el uso es prácticamente eliminada. Esto es de gran valor para aplicaciones que requieren ensamblaje y desensamblaje repetido. El bajo coeficiente de fricción asegura prácticamente que todas las fuerzas de ensamblaje aplicadas se conviertan en cargas de sujeción, dando como resultado que las roscas se mantengan firmes.

PROTECCION CONTRA CORROSION

El alambre de acero inoxidable austenítico 8/18 usado en los insertos Power Coil resisten la corrosión bajo condiciones ambientales normales. La acción galvánica dentro del ensamblaje de la rosca se reduce, incrementando la vida del ensamblaje y del tornillo.

La corrosión galvánica es la forma más significativa de corrosión y afecta a los insertos y a los tornillos. La corrosión galvánica aparece cuando metales distintos están en contacto en la presencia de una solución electrolítica. Todos los metales tienen grados diferentes de "actividad" o "nobleza" y pueden arreglarse en series galvánicas de actividad incrementada. El oro y el platino son los más nobles, mientras el zinc y el magnesio son los más activos. La solución electrolítica más común encontrada es agua ordinaria. El agua de mar o spray salado es más dañina por la alta concentración de sales disueltas.

La mejor manera de prevenir la corrosión galvánica es usar metales potencialmente similares y eliminar el conductor electrolítico. El activo del acero inoxidable usado en las roscas de los insertos Power Coil no está pasivado. Esto minimiza la posibilidad de que ocurra corrosión galvánica cuando se instalan en aluminio y magnesio o materiales similares. Algunas precauciones adicionales que deben tomarse en cuenta para prevenir la corrosión galvánica son:

1. Aislar los tornillos de los electrolitos. Esto puede hacerse a través de encapsulado o sellado.
2. Específicamente usar insertos recubiertos de cadmio. El acabado en cadmio proporciona una barrera contra la corrosión. Adicionalmente, el acabado en cadmio tiene propiedades lubricantes que minimizan el roce cuando se usan tornillos de acero inoxidable.
3. Aplicar pastas o compuestos inhibidores de corrosión al tornillo. Esto incluye al sellador zinc cromado (MIL-P-8585) y el sellador estroncio cromado (MIL-P-23377). Nota: Las pastas aplicadas al inserto helicoidal entre las roscas y el agujero pueden causar pérdida de la tolerancia propia. Por lo tanto se recomienda aplicar la pasta solamente al tornillo y no al inserto. Si el sellador cromo zinc es aplicado al agujero roscado debe rebajarse y aplicarse escasamente. El inserto debe instalarse mientras el sellador esta aun húmedo.
4. Dar una película de lubricante seco como el disulfato de molibdeno en los insertos, proporciona una barrera secundaria contra la corrosión.
5. Cuando sea práctico o cuando no interfiera con el ensamblaje, la junta externa deberá ser cubierta con una pintura adecuada.

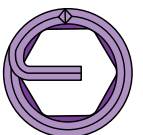
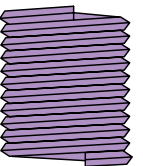
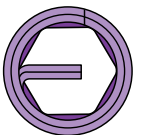
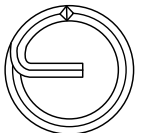
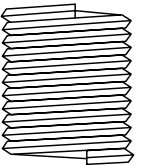
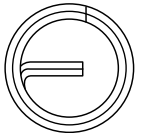

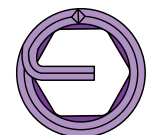
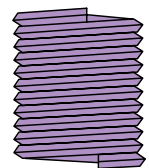
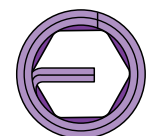
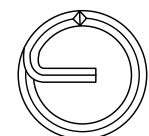
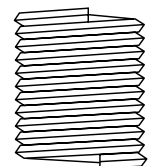
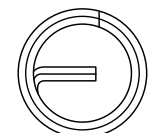

MATERIALES

Los insertos standard Power Coil están fabricados en acero inoxidable austenítico 304 (18/8) y ampliamente certificados como calidad aeroespacial de conformidad con la DTD 734 A. Los materiales alternativos incluyen aceros inoxidables 316 y una variedad de aplicaciones específicas para superficies recubiertas.

MATERIALES ALTERNATIVOS

Fósforo Bronce

Aleación no ferrosa de cobre estaño de acuerdo a BS2783 PB 102 E4 – es adecuada para trabajar a temperaturas entre -200° C a + 300° C

Inconel X-750

La aleación base níquel resistente a temperaturas de temple (especificaciones equivalentes SAE AS 7246, DIN/NF3018 W.NR 2.4669, UNS N07750). El Inconel X-750 se recomienda para el rango de temperaturas de -200° C a +550° C.

Nimonic 90

La aleación base níquel resistente a temperatura de temple de conformidad con BS2 HR 501 (especificaciones equivalentes W.NR 2.4632, UNS N07090). El Nimonic 90 es recomendable para trabajar a temperaturas entre -100° C a +650° C.

Material del Inserto	Temperatura Máxima		Aplicaciones típicas	Recubrimientos
	Pico	Continua		
Acero 304	425°C 800°F	315°C 600°F	Aplicaciones generales Para todos los materiales	FL, AG, CD
Acero 316	425°C 800°F	315°C 600°F	Incrementa la resistencia a la corrosión, para aplicaciones en agua salada	FL, AG, CD
Fósforo Bronce	300°C 572°F	235°C 455°F	Material de cobre, no magnético, aplicaciones de baja permeabilidad	AG, CD
Inconel X-750	650°C 1200°F	550°C 1020°F	Aeroespacial, turbinas ambientes corrosivos, Uso en altas temperaturas	AG
Nimonic 90	650°C 1200°F	550°C 1020°F	Aeroespacial y aplicaciones en turbinas	AG

ALTERNATIVAS DE TERMINADO Y RECUBRIMIENTO

Terminado Cadmio

Cadmio electro depositado de conformidad con DTD905/Def. Stan 03-19 especificaciones equivalentes FED. QQ-P416, LN 9368) El terminado cadmio proporciona una excelente barrera entre metales diferentes reduciendo dramáticamente los efectos de la corrosión galvánica, su alta lubricidad y excelente resistencia a la corrosión previene el roce y la sobremedida entre los componentes de la rosca. El terminado cadmio esta recomendado para trabajar en el rango de temperatura de -200° C a +235° C.

Las partes terminadas en Cadmio no deben

- Someterse a temperaturas por encima de 235° C (455° F)
- Ponerse en contacto con combustible o aceite caliente
- Ponerse en contacto con comida o agua potable.
- Ser usados con componentes de titanio (ya sea directa o indirectamente). A temperaturas elevadas pueden ocurrir resquebrajamiento y fallos en los componentes.
- El cadmio es altamente tóxico - consecuentemente deben tomarse cuidadosas precauciones cuando se embarca, se maneja y se instala.

Terminado Zinc

El zinc es depositado electrolíticamente de conformidad con BS3382. El zinc electro depositado es el terminado mas aplicado en la industria. El zinc esta recomendado para trabajar en el rango de temperaturas de -200° C a + 250° C.

Terminado Plata

La plata es depositada electrolíticamente de conformidad con DTD939. El terminado plata es usado para prevenir que haya roces o sobremedida entre los componentes de la rosca cuando se usa a altas temperaturas y es el más comúnmente usado en los tornillos para motores de aviación. El terminado plata esta recomendado para trabajar a temperaturas en el rango de -200° C a +650° C. Los insertos terminados en plata pueden ser utilizados con varios materiales incluyendo aleaciones de aluminio, aleaciones de magnesio, materiales resistentes al calor y a la corrosión, etc.

Los insertos terminados en plata no son recomendados para instalación en aleaciones de titanio que puedan exceder temperaturas de 300° C (570° F) Alta corrosión como resultado de la combinación de plata y titanio puede ocurrir en el alojamiento.

Película Lubricante seca

Sólida película de resistencia al calor bisulfuro de molibdeno, recubierto con una película lubricante seca de conformidad con MIL-L-0046010 provee un recubrimiento con bajo coeficiente de fricción con excelente capacidad de soporte de carga. La película lubricante seca previene el roce y las sobremedidas entre los componentes roscados y es particularmente efectivo en la aplicación de los insertos de seguridad. La película seca lubricante es recomendada para la operación en el rango de temperatura de -100° C a +250° C.

Terminado	Sufijo de No. De parte	Especificaciones a procesos aplicables
Recubrimiento plata	AG	DTD 939
terminado de cadmio	CD	QQP-416 ou DEF STD 03-19
película lubricante seca	FL	MIL-L-8937 ou MIL-L-46010
tintado rojo	-	aplicado a insertos de seguridad para efectos de identificación*

* Otros colores de tintado pueden utilizarse para efectos de identificación específica.

SELECCIÓN DE LA CORRECTA LONGITUD DEL INSERTO

Los insertos de rosca PowerCoil están disponibles en todos los tipos de rosca comunes. Hay cinco longitudes disponibles para cada medida. Es muy importante seleccionar la longitud correcta del inserto con efecto de equilibrar la dureza del material del tornillo con la dureza del material de alojamiento. Las cinco longitudes de insertos (Las recomendaciones de las roscas Power Coil), 1D, 1.5D, 2D, 2.5D y 3D se muestran en el área sombreada en la tabla de abajo.

Los números son calculados ya que los insertos no pueden medirse en estado libre (no instalado). Los números son múltiplos del tamaño de rosca nominal, o diámetro del inserto. Las longitudes actuales del inserto en posición instalada están listadas en las tablas de selección de insertos. Ahí se representa la longitud actual instalada más medio (1/2) paso. Usando la tabla siguiente la longitud de un inserto puede seleccionarse para conseguir un sistema suficientemente resistente para romper un tornillo antes de dañar el inserto o el material de alojamiento.

Longitud nominal recomendada de insertos basada en material de alojamiento vs. longitud de tornillo

UNIFICADO (fuente BS7752 Part 1:1994)

Resistencia en materiales de alojamiento (KSI)	Material del tornillo fuerza de tensión (KSI)									
	54	75	96	108	125	132	160	180	220	
10	2.0	2.5	3.0	3.0	-	-	-	-	-	
15	1.5	1.5	2.0	2.5	2.5	3.0	-	-	-	
20	1.0	1.5	1.5	2.0	2.0	2.0	2.5	3.0	3.0	
25	1.0	1.0	1.5	1.5	1.5	2.0	2.0	2.5	2.5	
30	1.0	1.0	1.0	1.5	1.5	1.5	2.0	2.0	2.5	
40	1.0	1.0	1.0	1.0	1.0	1.5	1.5	1.5	2.0	
50	1.0	1.0	1.0	1.0	1.0	1.0	1.0	1.5	1.5	

EJEMPLO: Si el material de alojamiento es 10KS1 y la tensión del tornillo es 54KSI, la longitud correcta del inserto es 2.0 de diámetro (2D).

METRICO

Resistencia en materiales de alojamiento (MPa)	Material del tornillo fuerza de tensión (MPa)							
	300	400	500	600	800	1000	1200	1400
70	1.5	2.0	2.5	2.5	-	-	-	-
100	1.0	1.5	1.5	2.0	2.5	3.0	-	-
150	1.0	1.0	1.5	1.5	2.0	2.0	2.5	3.0
200	1.0	1.0	1.0	1.0	1.5	1.5	2.0	2.5
250	1.0	1.0	1.0	1.0	1.0	1.5	1.5	2.0
300	1.0	1.0	1.0	1.0	1.0	1.5	1.5	1.5
350	1.0	1.0	1.0	1.0	1.0	1.0	1.5	1.5

EJEMPLO: Si el material de alojamiento es 150 Mpa y la tensión de la tuerca es 500Mpa, la longitud correcta del inserto es de 1.5 de diámetro (1.5 D)

PROYECCION DEL TORNILLO

Los insertos Power Coil están diseñados para ser usados con tornillos Standard, normales disponibles que no requieran de especificaciones especiales.

La tuerca debe engranar a lo largo de todo el inserto para asegurar la máxima firmeza del ensamblaje. Para asegurarnos contra engranajes parciales, se recomienda cortar siempre el arrastre del inserto. Esto también garantizará que las roscas de seguridad engranen en todas las roscas del tornillo. Si necesitan ver el diseño de cómo se hace, favor de contactar a Power Coil para asistencia.

NOTAS:

1. Se especifican las resistencias mínimas de los tornillos. Cuando se escoge una longitud de inserto, se debe poner atención a la resistencia máxima permitida por el tornillo o sus especificaciones.
2. La temperatura puede provocar variaciones significativas en los valores de resistencia, por lo tanto se debe permitir la compensación.
3. La importancia de los valores de corte deben tenerse en cuenta dado que el material de alojamiento esta sujeto a la presión de corte en la mayor parte del diámetro del agujero roscado.
4. Cuando los valores de resistencia caen entre dos valores en las tablas, se debe optar por el material hacia abajo del valor de corte, o el siguiente valor mas alto de resistencia a la tensión del tornillo.
5. Para asegurar la máxima resistencia, la longitud del tornillo y de la rosca, así como la profundidad del agujero roscado deben ser suficientes para asegurar el total engranaje de todos los filetes a lo largo de todo el inserto

INSERTOS PARA TORNILLOS DE SEGURIDAD (TORQUE COMUN)

Los insertos de seguridad Power Coil están diseñados para aplicaciones sujetas a los efectos de impacto y vibración cíclica. Los insertos de seguridad ejercen una fuerza de cierre en las rosca de los tornillos para prevenir su pérdida debido a vibración o impacto. Eliminan la necesidad de otras opciones, menos deseables y mas costosas de mecanismos de seguridad. Son excelentes en el "ajuste del tornillo" previniendo que el tornillo se desplace de su lugar.

COMO FUNCIONAN LOS INSERTOS DE SEGURIDAD

Los insertos de seguridad Power Coil ofrecen una seguridad adicional de cierre al inserto Standard. Esto se consigue gracias a la acción de uno o varios cierres poligonales de las roscas del inserto posicionados a lo largo del mismo, que ejercen presión radial en los flancos de la rosca. En cada vuelta de agarre la rosca de seguridad consta de un número tangencial de roscas que empujan dentro del diámetro menor de la rosca standard.

En la medida en que la rosca pasa a través de estas roscas de seguridad, los dispositivos se expanden aplicando presión radial o freno efectivo en la rosca del tornillo. Al retirar el tornillo roscado, las roscas de seguridad relajan su expansión a su forma original permitiendo repetir el roscado del tornillo y manteniendo su nivel de presión radial de seguridad.

Nota:

Con los insertos de seguridad Power Coil, se recomienda utilizar solamente tornillos cerrados recubiertos o tornillos lubricados. Cuando se utilicen tornillos no recubiertos o de acero inoxidable, debe utilizarse un compuesto anti-agarre, como por ejemplo, molibdeno disulfuro, que deberá utilizarse para reducir el roce y asegurar el ciclo máximo de vida. La vida de uso de un tornillo o perno usando los insertos de seguridad Power Coil también puede mejorarse al aplicarse una película lubricante seca o terminado en Cadmio.

UBICACION DE LAS ROSCAS DE SEGURIDAD

Para 1D, 1.5D y 2D veces la longitud del diámetro: El centro del inserto de seguridad debe ser igual a la mitad del inserto standard. Para las longitudes de 2.5 D y 3D del diámetro: El inserto de seguridad deberá situarse a la misma distancia del arrastre que los insertos Standard de 2D de longitud.

Los insertos de seguridad están marcados con rojo para su fácil identificación exclusivamente. Este color es soluble en alcohol y puede quitarse, si se desea.

RECUBRIMIENTO EN ROJO

Los insertos de seguridad Power Coil están generalmente coloreados con una pintura orgánica roja para efectos de identificación. El color no afecta la instalación o el trabajo del inserto y no requiere ser removido (en la mayoría de los casos). En casos en que se requiere extrema claridad (tales como instrumentos de ensamblajes de precisión en condiciones de limpieza) la pintura puede ser removida, remojando los insertos en una solución de alcohol desnaturalizado antes de su instalación.

Nota: También es esencial que el tornillo engrane perfectamente en todas las roscas del inserto para mayor resistencia.

Los insertos de seguridad PowerCoil pueden ser diseñados de conformidad con las necesidades específicas de un cliente.

En algunos casos y aplicaciones el apriete común puede ser disminuido o incrementado para una aplicación específica. En estos casos, favor de contactar a su representante PowerCoil para discutir sus necesidades específicas.

Nota. La instalación de los insertos de seguridad PowerCoil requiere el uso de una herramienta pre-rosca especial. Favor de comentar otras opciones de instalación con su agente PowerCoil.

VALORES DE APRIETE DE LOS INSERTOS DE SEGURIDAD POWERCOIL

METRICO GRUESO

Rosca mm x mm	Máximo Max (Nm)	Mínimo Min (Nm)
M2.2x0.45	0.14	0.02
M2.5x0.45	0.23	0.05
M3.0x0.50	0.45	0.10
M3.5x0.60	0.68	0.12
M4.0x0.70	0.90	0.15
M5.0x0.80	1.60	0.30
M6.0x1.00	3.00	0.40
M7.0x1.00	4.50	0.60
M8.0x1.25	6.00	0.80
M10.0x1.50	10.50	1.40
M12.0x1.75	15.50	2.10
M14.0x2.00	23.50	3.00
M16.0x2.00	31.50	4.20
M18.0x2.50	42.00	5.50
M20.0x2.50	54.00	7.00
M22.0x2.50	67.50	9.00
M24.0x3.00	80.00	10.50
M27.0x3.00	94.00	12.00
M30.0x3.50	108.00	14.00
M33.0x3.50	122.00	15.50
M36.0x4.00	136.00	17.50
M39.0x4.00	150.00	19.50

METRICO FINO

Rosca mm x mm	Máximo Max (Nm)	Mínimo Min (Nm)
M8.0x1.00	6.00	0.80
M10.0x1.00	10.50	1.40
M10.0x1.25	10.50	1.40
M12.0x1.25	15.50	2.10
M12.0x1.50	15.50	2.10
M14.0x1.50	23.50	3.00
M16.0x1.50	31.50	4.20
M18.0x1.50	42.00	5.50
M20.0x1.50	54.00	7.00
M22.0x1.50	67.50	9.00
M18.0x2.00	42.00	5.50
M20.0x2.00	54.00	7.00
M22.0x2.00	67.50	9.00
M24.0x2.00	80.00	10.50
M27.0x2.00	94.00	12.00
M30.0x2.00	108.00	14.00
M33.0x2.00	122.00	15.50
M36.0x2.00	136.00	17.50
M39.0x2.00	150.00	19.50
M36.0x3.00	136.00	17.50

Los valores de apriete siguen la norma
MP3329, MP3330, MP3331

PASO GRUESO AMERICANO UNC

Rosca inch x tpi	Máximo Max (lb in)	Mínimo Min (lb in)
2x56	1.25	0.19
3x48	2.00	0.44
4x40	3.00	0.63
5x40	4.69	0.81
6x32	6.00	1.00
8x32	9.00	1.50
10x24	13.00	2.00
12x24	24.00	3.00
1/4x20	30.00	4.50
5/16x18	60.00	7.50
3/8x18	80.00	12.00
7/16x14	100.00	16.50
1/2x13	150.00	24.00
9/16x12	200.00	30.00
5/8x11	300.00	40.00
3/4x10	400.00	60.00
7/8x9	600.00	82.00
1x8	800.00	110.00
11/8x7	900.00	137.00
11/4x7	1000.00	165.00
13/8x6	1150.00	185.00
11/2x6	1350.00	210.00

PASO FINO AMERICANO UNF

Rosca inch x tpi	Máximo Max (lb in)	Mínimo Min (lb in)
3x56	0.13	0.44
4x48	0.19	0.63
6x40	6.00	1.00
8x36	9.00	1.50
10x32	13.00	2.00
1/4x28	30.00	3.50
5/16x24	60.00	6.50
3/8x24	80.00	9.50
7/16x20	100.00	14.00
1/2x20	150.00	18.00
9/16x18	200.00	24.00
5/8x18	300.00	32.00
3/4x16	400.00	50.00
7/8x14	600.00	70.00
1x12	800.00	90.00
11/8x12	900.00	117.00
11/4x12	1000.00	143.00
13/8x12	1150.00	165.00
11/2x12	1350.00	190.00

Los valores de apriete siguen la norma
NASM8846

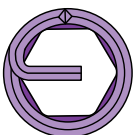
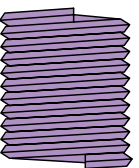
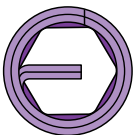
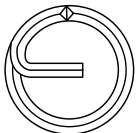
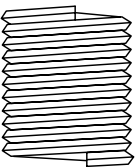
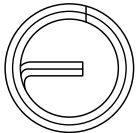

由高质量的铬镍不锈钢制造，PowerCoil螺套可以提供高强度的耐高温耐腐蚀的内螺纹。他们独特的设计确保复合性能的螺套不会被其他简单的紧固方式所替代。他们有着两种类型：普通型的螺套及锁紧型的螺套，这两种类别的螺套与其它相似的螺纹护套相比，不仅更轻更加经济，而且由于其紧凑的结构，使得他们很轻易的可以嵌入已存在的设计作品中而不需预留位置。

普通型螺套

PowerCoil普通型螺套由奥氏体不锈钢旋绕而成，就像所看见的一样为螺旋状。使用手动或者自动工具都可以安装，形成一个坚固的耐高温耐腐蚀的内螺纹。一旦安装完成，他们的位置就会在螺纹孔侧面和自身的螺旋张力的作用下保持不变。这种张力的存在是由于螺套的自由直径要大于安装直径。

锁紧型螺套

锁紧型螺套是一种特殊应用的螺套，多用于震动与碰撞的场合。除了先前提到的普通型螺套的一些优点之外，自锁型的螺套还有着特殊的扭力作用。这种扭力的获得是由于位于螺套中有着一个多边形的自锁螺纹，而恰恰是这个螺纹对外螺纹起着扭力的作用。自锁型螺套有着一圈切线锁弦，可以很容易的看见其内径比普通螺套的直径要小一些。当螺栓通过这个锁弦时，锁弦将给予轴向压力，提供一种扭矩于螺栓上。当旋下螺栓的时候，具有恢复能力的自锁螺套可以多次拆装而不降低螺纹的扭矩。

注意：在使用自锁型螺套的时候，最好能够使用电镀过或者润滑过的螺栓。

特征与利益

多年来，螺纹的护套的使用范围被大大的低估了。大多数情况下，人们都认为螺套这个独特的紧固件的主要作用就是去修复那些被损坏的螺纹。

他们的价格远远低于其他同样性能的紧固件类型，并且它小巧的尺寸设计可以在没有预留多少空间的情况下而很好的配合原来的产品。有别于其他的经济措施，使用螺套在增加质量和性能的同时又能降低整个产品的成本。螺套可以用于更薄更轻的材料而又不会牺牲螺纹强度。

螺套可以很好的保护螺纹，对松动，脱落，腐蚀，耐磨都有更好的特性。PowerCoil螺套采用奥氏体不锈钢制成，抗拉强度超过200000PSI，螺套硬度可达HRC43-50。螺套的内表面有着很好的表面精度，几乎可以消除由于摩擦而造成的磨损。

螺套菱形表面的设计需要足够的强度，以支持内外螺纹的连接。PowerCoil螺套可以安装在小尺寸的，没有压缩的范围之内（比如法兰），在节约重量与空间的同时提升螺纹强度。与螺栓公称直径相等的通常足以满足要求。

根据产品规格的不一样，有着很大范围的安装工具可供选择。在使用数量比较小的情况下，手动的安装工具会更加适合，而数量在非常大的情况下，那么电动和气动的安装工具是最为合适的。

强度

由于螺纹护套的特殊设计，它所制造的内螺纹大大的改善了残余应力的分布情况。在前三个螺纹孔上承担了70%的剪切力。螺套使螺栓与安装螺套的那螺纹底孔之间形成弹性连接，因而消除了内外螺纹之间的螺距和牙型半角误差。可在规定的长度上使每圈螺纹上的负荷均匀分布。

我们可以看到，在低强度的材料上，螺栓强度是越短越小为佳。

自由状态下的螺套直径比其欲装入的螺孔直径稍大，那么装入螺套后，一个由外向内的力对螺套进行施压，每圈都能最大可能性的独立的接触到基底材料。这样在静态和动态时的承载力都会增加。

标准螺栓 使用PowerCoil品牌螺套后的螺栓

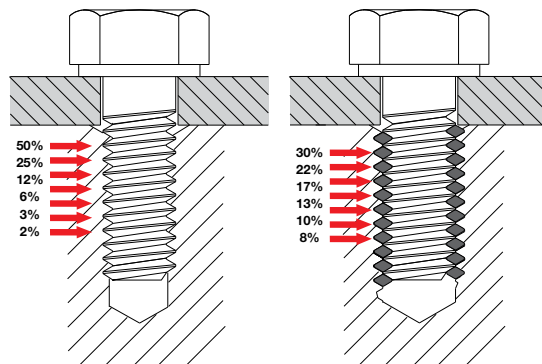

应力的消除

在没有堆放，锁定，或者到位的时候，应力是不存在的。当有外力的时候，外圈会给予一个应力，把螺套推倒一个合适的位置。

耐磨损

由于减小了螺纹的摩擦系数，高硬度材料所制造的纹螺套所产生的内螺纹表面精度会非常的好。这种特性在需要多次安装与拆卸过程中是十分有利的。

低的摩擦系数可以提供很好的组装扭矩，这样可以使螺纹配合的更好。

腐蚀保护

在一般的环境下，使用18/8奥氏体不锈钢生产的PowerCoil螺套更加的耐腐蚀。由于减少了在螺纹拆卸时产生的电流效应，增加了寿命。

在紧固系统中最严重的腐蚀就是电流效应。因为电解性，在不同材质的材料在相互接触的时候，腐蚀就会发生。所有的金属都体现着活跃的或者不活跃的特性，在活跃的时候，腐蚀性会增加。黄金和白金是最不活跃的，而镁和锌最为活跃。最为常见的电解质溶液是水溶液，因为高浓度的电解盐的存在，海水和含盐的液体特别具有腐蚀性。

最好的阻止腐蚀的方法是寻找一个合适的材料来消除电解质载体，有不锈钢制成的PowerCoil螺套是非钝化的，当把这样的螺套安装在铝镁材料为基底材料的工件上时就可以更好的保护材料，尽可能的减少腐蚀。

一些常用的预防腐蚀的方法如下：

通过密封或封口的方式，独立基底材料于电解质中特殊的镀铬螺纹护套。这样的螺套提供一个屏障去减少腐蚀。此外，镀铬有着很好的润滑作用，在使用不锈钢螺栓的时候有着更好的性能。

使用抗腐蚀性好的或者复合螺栓。这些措施包括锌铬酸盐底漆(mil-8585)和镍铬酸盐底漆(mil-23377)。注：这种行为会造成精度的损失。因此有人建议用粘着只用于螺栓，而不应用于螺套。如果锌铬酸盐底漆适用于螺纹底孔，那么螺套的安装还是需要保持湿润的。

使用干性润滑剂的螺套，比如镀钼。这样也可以提供一定的耐腐蚀性。

根据实际的情况，当不会引起整体效果的时候，最好能够在紧固件的外部涂上油漆。

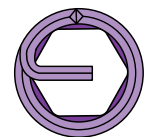
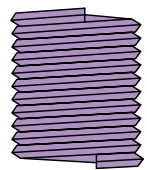
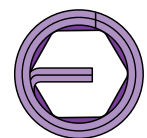
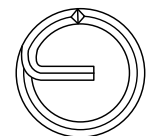
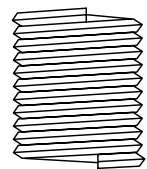
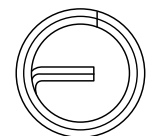

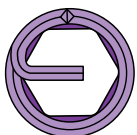
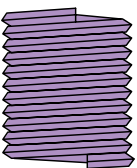
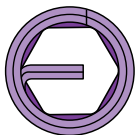
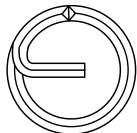
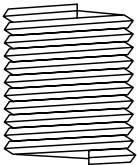
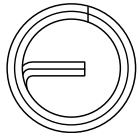

材料

PowerCoil标准螺套由具有航空标准的304 (18/8)奥氏体不锈钢制成,符合DTD 734A标准。包括316不锈钢以及一些特殊应用的表面涂层处理。

可以选择的材料

磷青铜

有色金属磷青铜合金螺套,符合BS2783 PB 102 EH,适用温度范围:-200°C至300°C。

镍合金螺套

耐高温高硬镍基合金(相当于SAE A57246,DIN/NF-3018.W.NR 2.4669,UNS NO7750)。适用温度范围:-200°C至550°C。

铌锰合金90

耐高温高硬镍基合金符合BS2 HR 501(相当于W.NR 2.4632,UNS NO7090)。适用温度范围:-100°C至650°C。

螺套材料	最大温度		应用	涂层
	峰值	持续		
304不锈钢	425°C 800°F	315°C 600°F	通用所有材料	FL,AG,CD
316不锈钢	425°C 800°F	315°C 600°F	增加抗腐蚀能力, 盐水环境	FL,AG,CD
磷青铜	300°C 572°F	235°C 455°F	铜件,非磁性, 低渗透场合	AG,CD
镍合金	650°C 1200°F	550°C 1020°F	航空,汽轮机, 抗腐蚀,高温场合	AG
铌锰合金	650°C 1200°F	550°C 1020°F	航空,汽轮机领域	AG

可选精度和涂层:

镀镉

镀镉符合DTD904/DEF Stan 03-19(相当于FED,QQ-P-416,LN 9386)。镀镉可以及其优秀的屏蔽产生于不同金属间的电流腐蚀,它的高润滑功能可以更好的预防螺纹磨损。适用温度范围:-200°C至235°C。

镀镉产品不能用于以下场合:

- 温度超过235°C (455°F)
- 与油类接触
- 与饮用水,食品接触
- 由钛组成的期间(包括直接的或者间接的)因为在不断提升温度的情况下,它会变的较为脆弱。
- 镉具有很强的毒性-因此在运输,操作,安装时需特别小心。

镀锌

镀锌符合BS3328标准。镀锌可以获得最佳的电镀精度,在工业上有着广泛的应用。适用温度范围:-200°C至250°C。

镀银

镀银符合DTD 939标准。镀银在高温条件下具有保护螺纹的作用,常用于飞机引擎的紧固部分。适用温度范围:-200°C至650°C。镀银的螺纹护套可以安装于许多不同的材料上,比如铝合金,镁合金,耐腐蚀耐高温的材料等等。镀银的螺纹护套不推荐用于钛合金,因为这种合金很可能超过其服务温度300°C (570°F)。在所安装的材料上可能会出现由于银与钛的化合作用而产生的压力侵蚀。干性润滑剂涂层

固态的二硫化钼涂层符合MIL-L-0046010标准,提供了一个低摩擦系数的涂层并有着极好的承载能力。这种干性润滑剂涂层在螺纹元件和自锁应用的场合减少了很多麻烦。适用温度范围:-100°C至250°C。

涂层	零件号后缀	特殊标准及应用
镀银	AG	DTD 939
镀镉	CD	QQ-P-416 或者DEF STD 03-19
干性润滑剂	FL	MIL-L-8973, MIL-L-46010
红染料	-	自锁螺套或者特殊标识应用*

*其他颜色染料也用于一些特殊的标识目的。

选择正确的螺纹护套长度

PowerCoil螺套有着品种齐全的螺纹护套。每种螺纹都有5种螺纹护套的长度可以选择。选择合适的螺纹护套长度对于获得螺栓张力及基底材料的剪切强度的平衡是非常重要的。5个螺套的长度(推荐PowerCoil品牌)1D,1.5D,2D,2.5D,3D在其下表格的阴影区域显示。这些都是在螺套没有安装(自由状态)情况下的计算测量值。这些值是螺套名义上的螺纹尺寸,直径。实际上的螺套安装后长度位于螺套长度选择表中。他们体现了实际的安装长度增加1/2英寸。根据下表可以选择出合适的螺套长度,在这种长度情况下,产生一个足够强的螺纹系统,在基底材料损坏前,让螺栓先行碎裂,以保护基地材料。

推荐的螺套公称长度
(基地材料剪切强度VS螺栓抗拉强度)

母材的剪切力强度 (KPSI)	螺栓的最小抗拉强度 (KPSI)									
	54	75	96	108	125	132	160	180	220	
10	2.0	2.5	3.0	3.0	-	-	-	-	-	-
15	1.5	1.5	2.0	2.5	2.5	3.0	3.0	-	-	-
20	1.0	1.5	1.5	2.0	2.0	2.0	2.5	3.0	3.0	-
25	1.0	1.0	1.5	1.5	1.5	2.0	2.0	2.5	2.5	-
30	1.0	1.0	1.0	1.5	1.5	1.5	2.0	2.0	2.5	-
40	1.0	1.0	1.0	1.0	1.0	1.5	1.5	1.5	2.0	-
50	1.0	1.0	1.0	1.0	1.0	1.0	1.0	1.0	1.5	1.5

例:如果母材的剪切强度为10KPSI,而螺栓的最小抗拉强度为54KPSI,那么此时正确的螺套长度为2.0倍直径(2.0D)。

母材的剪切力强度 (MPa)	螺栓的最小抗拉强度 (MPa)							
	300	400	500	600	800	1000	1200	1400
70	1.5	2.0	2.5	2.5	-	-	-	-
100	1.0	1.5	1.5	2.0	2.5	3.0	-	-
150	1.0	1.0	1.5	1.5	2.0	2.0	2.5	3.0
200	1.0	1.0	1.0	1.0	1.5	1.5	2.0	2.5
250	1.0	1.0	1.0	1.0	1.0	1.5	1.5	2.0
300	1.0	1.0	1.0	1.0	1.0	1.5	1.5	1.5
350	1.0	1.0	1.0	1.0	1.0	1.0	1.5	1.5

例:如果母材的剪切强度为150MPa,而螺栓的最小抗拉强度为600MPa,那么此时正确的螺套长度为1.5倍直径(1.5D)。

螺套规划

PowerCoil的螺套设计都是根据标准的螺栓进行的,一些特殊的紧固件不属于其中。

螺栓需要整个的进入螺套以获得最大的力。为了防止仅仅只有局部接触，我们推荐螺套安装尾部总是需要去除的。这样就可以保证整个锁紧型螺套包含着螺栓的全部螺纹。如果设计参数反而需要预防这个现象，联系PowerCoil以获得帮助。

注意：

1. 螺栓的拉伸强度是特殊的最小值。当确认了螺套长度后，要考虑到螺栓所允许的最大抗拉强度。
2. 温度可能造成强度值的很大变化，有时候温度补偿是允许的
3. 重要的剪力值应该记住，因为基底材料所受的应力位于丝锥螺纹的最大直径处
4. 当强度值在2个值之间的时候，选择基底材料的最低剪力值或者螺栓的最高抗拉强度值。
5. 为了获得最大的值，螺栓长度及螺纹长度以及螺纹深度应该足以让螺栓整个儿插入。

锁紧型（预扭力矩）螺纹护套

PowerCoil品牌锁紧型螺套是专为振动或者冲击的场合而设计的。锁紧型的螺套存在着一个预扭矩作为螺纹紧固件，防止在振动或者冲击的场合下松动。他们不再需要其他不太理想而昂贵的锁定机制。它们起着出色的“调节螺钉”的作用，防止紧固件滑落。

锁紧型螺套是如何工作的

PowerCoil螺套提供一个更加安全的预锁紧扭矩。实现这一目标是在插入的长度上有着一个或多个多边形线圈，对阳螺纹向其子午线施加压力。

去除阳螺纹，锁线圈放松为原来的形式，允许多次使用，同时又能保留可测量水平扭矩。

请注意：

我们强烈的推荐在使用PowerCoil锁紧型螺套时，需要使用配合紧凑的，或者有润滑处理的螺栓。如果使用热处理过的螺栓或者不锈钢的螺栓时，必须注意到，有时会产生化合作用，比如钼，二硫化物等等。必须使用最小的抓紧力以获得最大的使用寿命。为了增加PowerCoil锁紧型螺套的使用寿命，推荐使用干性润滑剂涂层或者镀镉。

锁紧线圈的位置：

对于1D,1.5D,2D长度的螺套，锁紧线圈的位置位于整个螺套普通型线圈的中部。对于2.5D,3D长度的螺套，锁紧线圈的位置与2D直径的螺套位置是一样的。锁紧型的螺套染成红色以更好的识别，这种染料如果需要的话，可以用酒精很轻易的去除。

染成红色

PowerCoil锁紧型螺套有机的染成红色以易于标识。这种红色的染料不会影响按照，而且在需要的时候也可以很方便的去除，实际上，大多数的情况下，不需要去除。在一些需要去除的场合（比如在无尘式组装紧密仪器），那么在安装这种锁紧型的螺套前，需要预先在酒精中进行浸泡。

PowerCoil锁紧型螺套的扭矩值

公制粗牙MC			公制细牙MF		
螺纹	最大扭矩	最小扭矩	螺纹	最大扭矩	最小扭矩
mm*mm	(Nm)	(Nm)	mm*mm	(Nm)	(Nm)
M2.2x0.45	0.14	0.02	M8.0x1.00	6.00	0.80
M2.5x0.45	0.23	0.05	M10.0x1.00	10.50	1.40
M3.0x0.50	0.45	0.10	M10.0x1.25	10.50	1.40
M3.5x0.60	0.68	0.12	M12.0x1.25	15.50	2.10
M4.0x0.70	0.90	0.15	M12.0x1.50	15.50	2.10
M5.0x0.80	1.60	0.30	M14.0x1.50	23.50	3.00
M6.0x1.00	3.00	0.40	M16.0x1.50	31.50	4.20
M7.0x1.00	4.50	0.60	M18.0x1.50	42.00	5.50
M8.0x1.25	6.00	0.80	M20.0x1.50	54.00	7.00
M10.0x1.50	10.50	1.40	M22.0x1.50	67.50	9.00
M12.0x1.75	15.50	2.10	M18.0x2.00	42.00	5.50
M14.0x2.00	23.50	3.00	M20.0x2.00	54.00	7.00
M16.0x2.00	31.50	4.20	M22.0x2.00	67.50	9.00
M18.0x2.50	42.00	5.50	M24.0x2.00	80.00	10.50
M20.0x2.50	54.00	7.00	M27.0x2.00	94.00	12.00
M22.0x2.50	67.50	9.00	M30.0x2.00	108.00	14.00
M24.0x3.00	80.00	10.50	M33.0x2.00	122.00	15.50
M27.0x3.00	94.00	12.00	M36.0x2.00	136.00	17.50
M30.0x3.50	108.00	14.00	M39.0x2.00	150.00	19.50
M33.0x3.50	122.00	15.50	M36.0x3.00	136.00	17.50
M36.0x4.00	136.00	17.50	M39.0x3.00	150.00	19.50
M39.0x4.00	150.00	19.50			

锁紧型螺套符合MP3329, MP3330, MP3331标准

PowerCoil锁紧型螺套的扭矩值

统一标准粗牙螺纹-UNC			统一标准细牙螺纹-UNF		
螺纹	最大扭矩	最小扭矩	螺纹	最大扭矩	最小扭矩
Inch*TPI	(lb in)	(lb in)	Inch*TPI	(lb in)	(lb in)
2x56	1.25	0.19	3x56	0.13	0.44
3x48	2.00	0.44	4x48	0.19	0.63
4x40	3.00	0.63	6x40	6.00	1.00
5x40	4.69	0.81	8x36	9.00	1.50
6x32	6.00	1.00	10x32	13.00	2.00
8x32	9.00	1.50	1/4x28	30.00	3.50
10x24	13.00	2.00	5/16x24	60.00	6.50
12x24	24.00	3.00	3/8x24	80.00	9.50
1/4x20	30.00	4.50	7/16x20	100.00	14.00
5/16x18	60.00	7.50	1/2x20	150.00	18.00
3/8x18	80.00	12.00	9/16x18	200.00	24.00
7/16x14	100.00	16.50	5/8x18	300.00	32.00
1/2x13	150.00	24.00	3/4x16	400.00	50.00
9/16x12	200.00	30.00	7/8x14	600.00	70.00
5/8x11	300.00	40.00	1x12	800.00	90.00
3/4x10	400.00	60.00	11/8x12	900.00	117.00
7/8x9	600.00	82.00	11/4x12	1000.00	143.00
1x8	800.00	110.00	13/8x12	1150.00	165.00
11/8x7	900.00	137.00	11/2x12	1350.00	190.00
11/4x7	1000.00	165.00			
13/8x6	1150.00	185.00			
11/2x6	1350.00	210.00			

锁紧型螺套符合NASM8846标准

注意：这些值是螺栓完全进入螺套所需的最大值

PowerCoil锁紧型螺套可以根据客户的需要进行定制。此时，预扭矩的力可以根据情况的不同略有增加或者减少以满足特定的应用。这时，请联系当地的代理商以讨论合适的应用。

注意：安装PowerCoil锁紧型螺套需要特殊的预拉伸工具，请向PowerCoil代理商进行咨询。

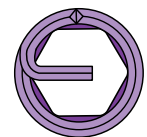
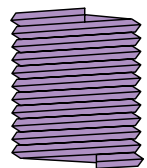
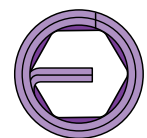
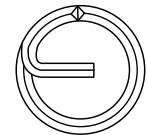
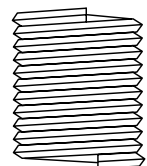
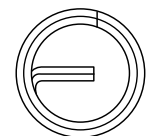

PowerCoil(パワーコイル)のワイヤースレッドインサートは高品質クロムニッケルステンレス鋼ワイヤーから製造されており、温度変化や腐食の影響に強い高強度の内部ねじ山を形成します。PowerCoil(パワーコイル)の特殊なデザインが生み出すねじ山は、他のどんな一点締結法も及ばない優れた複合性能を持ちます。PowerCoil(パワーコイル)のスレッドインサートにはフリーランニングとロックタイプの二種類があり、どちらも同類のスレッドインサート製品よりはるかに軽量化、低コスト化されています。また、小型化に成功したPowerCoil(パワーコイル)のインサートは、通常、母材に特別な設計を加えることなく使用することが可能です。

フリーランニング

PowerCoil(パワーコイル)のフリーランニングインサートは、スプリング状に巻かれた高精度オーステナイト系ステンレス鋼ワイヤーから造られており、多様な手動および電動の挿入工具の1つを使用して装着した後は、温度変化や腐食に強い耐久性を示す永久的な内部ねじ山を形成します。装着後のインサート位置は、インサートがタップ孔より一回り大きめに設計されている為に生じるインサートとタップ孔側面間の半径方向の圧力によって保持されます。

ロックタイプ

ロックタイプ(プリベリントルク)インサートは周期的な振動や衝撃を受ける機械への使用に最適な製品です。フリーランニングインサートの利点に加えプリベリントルクによる締結力を持ち、より強力な固定力を示します。インサート中のコイル1-2巻きが多角形のグリップコイルとなっており、この部分がおねじの側面を締め付け強力な締結力を与えます。これらのグリップコイルは幾つかの接線に沿ったロックングコードを持ち、これが通常のフリーランニングコイルの内径に突き出した形状となっています。おねじがインサートのロック部分を進んでいくにつれて、突出部が押し込まれこの半径方向の圧力(プリベリントルク)がおねじを更に強く締め付けます。おねじを取り出した場合、ロックングコイルは再び元の形状に戻り十分なプリベリントルクを維持するため繰り返し使用が可能です。

注:ロックタイプインサートには高密度メッキ処理又は潤滑剤を塗装したボルト又はスクリューの使用をお勧めします。

製品の特徴と利点

いままで、らせん状ワイヤースレッドインサートは損傷したねじ目を補修するための製品と誤解されてきたために、その高い利用価値は軽視されてきました。

らせん状ワイヤースレッドインサートは同種のスレッドインサートと比較し、はるかに軽量化、低コスト化されており、そのコンパクトなサイズから、通常、既存設計に変更を加えることなく使用することが可能です。また他の多くの経済戦略と異なり、PowerCoil(パワーコイル)インサートを導入することによって、経営全体のコスト削減が可能になるだけでなく製品の品質や性能を高めることも可能となります。PowerCoil(パワーコイル)インサートの使用で、ねじ山の締結力を損うことなく母材をより薄く軽量化することができます。

オーステナイト系ステンレス鋼ワイヤーから造られるPowerCoil(パワーコイル)ワイヤースレッドインサートは、剥離、焼付、侵食、磨耗作用によって起こるめねじの損傷を防ぎ、

200,000 psi以上の引っ張り強度とRc43-50の強度を持ちます。インサート表面は非常に滑らかな仕上げがされており、摩擦によるめねじの損傷を防いでいます。

菱形のワイヤーで造られた連続的ならせん状コイル形状により、内部と外部のスレッドを保持するための厚い構造が不要となりました。PowerCoil(パワーコイル)インサートは、小さなボスやフランジ、またスペースの制限がある部分にも使用可能なので、高い締結力を保持したままスペースや重量の軽減化に貢献します。通常、ボス半径はボルト径と同等あれば十分です。

パワーコイルでは、それぞれの使用用途に適したインサート挿入工具を用意しています。小規模または補修作業には手動挿入工具が、大規模な工程には電動式、エア式工具が準備してあります。

製品の長所

ワイヤースレッドインサートの高い柔軟性によって、今までのタップ孔と比較し応力が一部に集中することなく全体に分配されます(インサート未装着の場合、最初の3山にせん断力の70%近くがかかる)。インサートの高い柔軟性によって、通常のタップ孔に存在するねじ山のピッチと角度の誤差の補正を助け、これによって得られた残留力をらせん状のフープ応力へ変換しタップ孔側面へ分配することが可能となります。これによって荷重許容量は大きく改善されます。これらの長所によって、設計に際し強度の低い素材に対してもボルト強度を基に安心して小さな短いねじ山を使用することが出来ます。

高い引張り強度を持つコイルから造られるワイヤースレッドインサートは、挿入時に軽く絞り込まれ、装着後は外向きに働くバネ作用によって一定位置に固定されます。各コイルは母材と最大の接触面を持つよう伸縮し、静のおよび動的荷重許容量が改善されます。

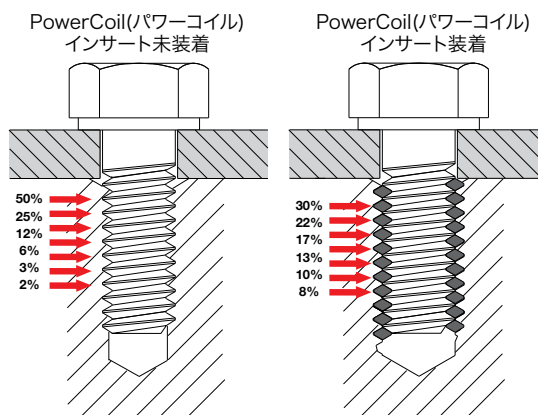

母材へのゼロ負荷

PowerCoil(パワーコイル)インサートの装着には杭打ち、締め付け、スエーピング、キーイングなどの工程が無いことから、母材にかかる負担は事実上ゼロです。インサートの外向きに働くバネ作用がインサートを一定位置に固定します。

耐摩耗性

素材の高い硬度と表面の滑らかな仕上げにより、パワーコイルインサートのねじ山の磨耗は事実上ゼロとなり、組立てと解体頻度の高い用途にも最適なインサートとなります。低い摩擦係数を持つことによって、組立て工程の加力は事実上全て締結力へと変換され、強い固定力を持ちます。

腐食防止

在一般的環境下、使用18/8奥氏体不銹鋼的PowerCoil螺套更加的耐腐PowerCoil(パワーコイル)インサートに使用されている18/8オーステナイト系ステンレス鋼ワイヤーは、通常の使用環境において耐腐食性を持ちます。組立部におけるガルバニック作用による影響が減少し耐久性も高まります。

ガルバニック腐食はインサートと締め具に最も大きな影響を与える腐食作用で、電位差のある金属が電解質溶液を媒体として接触した場合に生じます。全ての金属は特有の電気的活性度と非活性度を持ち、活性度順に金属が並べられたものが電位列です。金と白金が最も電位が高く(貴の金属)で、亜鉛とマグネシウムが最も電位が低い(卑な金属)となります。最も頻繁に影響を与える電解質は水、海水または塩水噴霧では淡水より溶解塩分が多いため、腐食作用が進行し易くなります。

ガルバニック腐食を防止する最善の方法としては、電位差の少ない金属を使い電解質との接触を避けることです。パワーコイルワイヤースレッドインサートに使われているステンレス鋼は不動態化されていないため、アルミニウムやマグネシウムの母材に装着した場合のガルバニック腐食の危険を最小に抑えることが出来ます。この他に、ガルバニック腐食を防ぐ為には以下のような予防策が効果的です。

締め具と電解質の接触を防ぎ、ガスケットやシーリングを使用するカドミウムメッキのインサートを使用する。カドミウムメッキはインサート表面に防食層を形成して腐食を防ぎます。またカドミウムメッキはステンレス鋼ねじが使用された場合に潤滑材としての役割も果たしかじりを防止します。

亜鉛クロメートプライマー(MIL-P-8585)やストロンチウムクロメートプライマー(MIL-P-23377)などの腐食防止ペーストまたはコンパウンドをねじに塗る。注:コイルスレッドインサートにペーストを塗った場合、ペーストの一部がワイヤーと孔の間に入り適正な公差が得られない場合があります。この問題を防ぐ為に、ペーストはインサートには塗らず、ねじにのみ塗ることをお勧めします。また、亜鉛クロメートプライマーをタップ孔に塗る場合は、薄めてから少量使用することをお勧めします。インサートはプライマーが乾く前に挿入して下さい。

モリブデンジスルフィドなどのドライフィルム潤滑材をインサートに使用することによって、第二の防食層を形成させる

組立て完成した機器等に支障を与えない場合は、外部接合部に適切な塗装を施す

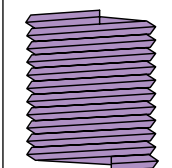
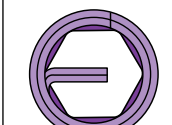
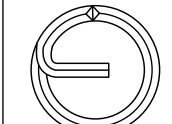
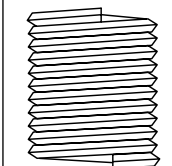
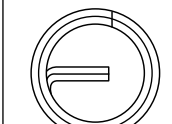
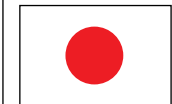

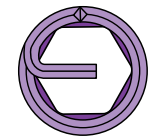
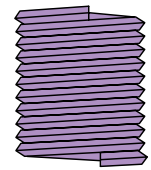
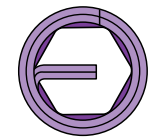
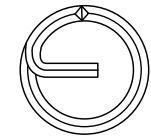
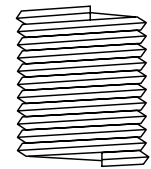
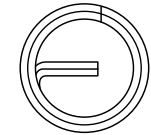

PowerCoil(パワーコイル)標準インサートは、高品質を保証された航空機材用の品質を持つ304 (18/8)オーステナイト系ステンレス鋼から造られており、DTD 734A規格に準拠しています。また、316ステンレス鋼や各用途に適したコーティングも使用しています。

その他の材質

りん青銅

BS2783 PB 102 EHに準じた銅とすずの非鉄合金で-200°Cから+300°C範囲の用途向け

インコネルX-750

耐熱性があり析出硬化するニッケル合金(SAE AS 7246 DIN/NF 3018, W.NR 2.4669, UNS N07750規格と同基準)で、-200°Cから+550°C範囲の用途向け

ナイモニック 90

BS2 HR 501規格(W.NR 2.4632, UNS N07090規格と同基準)に準拠する耐熱性があり析出硬化するニッケル合金で、-100°Cから+650°C範囲の用途向け

インサート材質	最高温度		主な用途	コーティング
	ピーク時	継続的		
304ステンレス	425°C 800°F	315°C 600°F	全ての金属の一般用途向け	FL,AG,CD
316ステンレス	425°C 800°F	315°C 600°F	高い防食性を持ち、海上用途向け	FL,AG,CD
りん青銅	300°C 572°F	235°C 455°F	銅部品、非磁性、低磁性用途向け	AG,CD
インコネル X-750	650°C 1200°F	550°C 1020°F	航空宇宙、タービン、腐食性環境、高温用途	AG
ナイモニック 90	650°C 1200°F	550°C 1020°F	航空宇宙、タービン用途向け	AG

仕上げとコーティング

カドミウムメッキ

DTD904-Def Stan 03-19規格(FED, QQ-P-416, LN 9368規格と同基準)に準じ電氣的にカドミウムを付着させたカドミウムメッキは、電位差のある金属間でのガルバニック腐食を防ぐ優れたバリアーの役割を果たし、その高い潤滑性と防食性からねじ部品間の焼付けやかじりを防ぎます。カドミウムメッキは-200°Cから+235°C範囲の用途向けです。

ただしカドミウムメッキ部品は次のような用途には使用できません

- +235°C(+455°F)以上
- 燃料や高温の油と接触する場合
- 食品や飲料水と接触する場合
- 高温で脆化して破損する恐れがあるため、チタン部品と(直接的または間接的に)一緒に使用する場合
- カドミウムは非常に毒性の強い物質ですので取り扱いには十分に注意して下さい

亜鉛メッキ

BS 3382規格に従い電氣的に付着された亜鉛メッキは、業界で最も広く普及している電気メッキです。亜鉛は-200°Cから+250°C範囲の用途向けです。

銀メッキ

DTD 939規格に従い電氣的に付着された銀メッキは、高温使用時における焼付や磨耗防止の役目を果たし、航空機用エンジンファスナーに広く使用されています。銀メッキは-200°Cから+650°C範囲の用途向けです。アルミニウム合金、マグネシウム合金、耐食及び耐熱材など様々な材質に使用できます。

銀メッキインサートは次の用途にお勧めしません

使用温度が300°C(570 °F)を超える恐れのあるチタン合金への使用。内部で銀とチタンの応力腐食が発生する危険があります。

ドライフィルム潤滑材

MIL-L-0046010規定に従い固体薄膜熱処理されたモリブデンジスルフィドドライフィルム潤滑材によるコーティングは低い摩擦係数と高い荷重許容性を与え、部品間の焼付やかじりを

防ぎます。特にロックタイプインサートへの使用に効果があります。ドライフィルム潤滑材は-100°Cから+250°C範囲の用途向きです。

メッキ/仕上げ	部品番号, 接尾字	関連規格用
銀メッキ	AG	DTD 939
カドミウムメッキ	CD	QQP-416または DEF STD 03-19
ドライフィルム潤滑材	FL	MIL-L-8937または MIL-L-46010
着色(赤色)	-	識別の為にロックタイプインサートは赤色に着色してあります*

*特別な識別目的で、赤色以外の着色がされる場合もあります

適正なインサートの長さの選定方法

PowerCoil(パワーコイル)ワイヤースレッドインサートは一般に使用されている全てのねじ規格に対応しています。各ねじサイズ毎に5種類のインサート長があり、適正なインサートの長さを選ぶことはボルトの引っ張り強度と母材のせん断強度のバランスを取る上で非常に重要となります。5種類のインサートの長さ(パワーコイルワイヤースレッドインサート使用時の推奨値)、1D、1.5D、2D、2.5D、3Dは次の表の影になった部分に示されています。未挿入時のインサートからはこれらの数値は測定出来ないため、表の値はインサートのねじ山サイズまたは径の倍数として計算されています。装着状態での実際のインサートの長さはインサート選定表に示されており、実際の挿入深さに1/2ピッチが加算された値となっています。次の表を用いて選定されたインサートの長さは、母材またはインサートが破損する前またはボルトが抜ける前にボルトが破損する長さです。

母材強度とボルト強度を基に選定した呼びインサートの長さ
ユニファイ

母材のせん断強度 (KPSI)	ボルトの最低極限引張り強度 (KPSI)							
	54	75	96	108	125	132	160	180 220
10	2.0	2.5	3.0	3.0	-	-	-	-
15	1.5	1.5	2.0	2.5	2.5	3.0	3.0	-
20	1.0	1.5	1.5	2.0	2.0	2.0	2.5	3.0
25	1.0	1.0	1.5	1.5	1.5	2.0	2.0	2.5
30	1.0	1.0	1.0	1.5	1.5	1.5	2.0	2.0
40	1.0	1.0	1.0	1.0	1.0	1.5	1.5	1.5
50	1.0	1.0	1.0	1.0	1.0	1.0	1.0	1.5

例:母材のせん断強度が10KSIでボルトの引っ張り強度が54KSIの場合、適正なインサートの長さはインサートの径の2.0倍(2D)となります

母材の剪断力強度 (MPa)	メートル 螺絲の最小抗拉強度 (MPa)							
	300	400	500	600	800	1000	1200	1400
70	1.5	2.0	2.5	2.5	-	-	-	-
100	1.0	1.5	1.5	2.0	2.5	3.0	-	-
150	1.0	1.0	1.5	1.5	2.0	2.0	2.5	3.0
200	1.0	1.0	1.0	1.0	1.5	1.5	2.0	2.5
250	1.0	1.0	1.0	1.0	1.0	1.5	1.5	2.0
300	1.0	1.0	1.0	1.0	1.0	1.5	1.5	1.5
350	1.0	1.0	1.0	1.0	1.0	1.0	1.5	1.5

例:母材のせん断強度が150MPaでボルトの引っ張り強度が600MPaの場合、適正なインサートの長さはインサートの径の1.5倍(1.5D)となります

ボルトの突起

PowerCoil(パワーコイル)のワイヤースレッドインサートは特別な工具を必要としない一般に使用されている標準規格のボルトとねじに対応します。

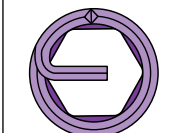
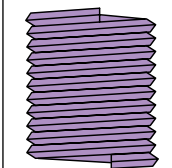
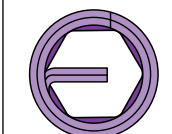
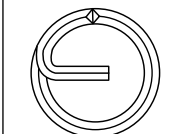
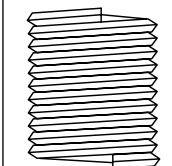
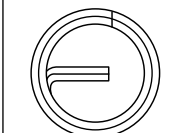
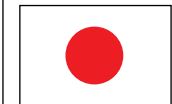

組立て後の最大強度は、ボルトのねじ部がインサート全てにかみ合った時に得られます。完全にボルトとインサートがかみ合うようにするためには、タングを折取ることをお勧めします。また、タングを折り取ることによってロックングコイルが完全にボルトのねじ部とかみ合ったことを確認できます。設計上の理由でこれが可能でない場合は、PowerCoil(パワーコイル)にご相談ください。

注意:

表に示されたボルト引張り強度は仕様上の最小値です。インサートの長さを選定する際には、ボルトの設計仕様書または購入仕様書に示された最大引張り強度も考慮して下さい

使用温度によって強度に大きなばらつきが出るので、温度による補正が必要となります

母材はタップ孔のねじ山の外径部分でせん断応力を受ける為、母材せん断強度は重要な要素となります

強度が表の数値の中間値となった場合、次に低い母材せん断強度または次に高いボルト引張り強度を選んでください

最適な最大強度を得るためには、ボルトの長さ、ボルトねじ山の長さ、タップ孔の深さがインサート全てがかみ合うのに十分な値を持つ必要があります

ロックタイプ(プリベリントルク)インサート

PowerCoil(パワーコイル)のロックタイプインサートは、周期的な振動や衝撃を受ける環境下での用途用に設計されています。ロックタイプインサートはプリベリントルクでおねじを締め付け、振動や衝撃によるボルトの緩みを防ぐため、このような用途に最適といえなく、さらにコストのかかる他の戻り止め機構を採用する必要がなくなります。ボルトのクリープを抑えるロックタイプインサートは調整ねじなどの用途に最適です。

ロックタイプインサートの仕組み

PowerCoil(パワーコイル)ロックタイプインサートはプリベリントルクによって、さらに強力な締結力を与えます。ロックタイプインサートでは、インサート中のコイル1-2巻きが多角形のグリップコイルとなっており、この部分がおねじの側面を締め付け強力な締結力を与えます。これらのグリップコイルは幾つかの接線に沿ったロックングコードを持ち、これがフリーランニングコイルの内径に突き出した形状となっています。おねじがインサートのロック部分を進んでいくにつれて、突出部が押し込まれこの半径方向への圧力(プリベリントルク)がおねじを更に強く締め付けます。おねじを取り出した場合、ロックングコイルは再び元の形状に戻り大きなプリベリントルクを維持するために繰り返し使用が可能です。

ただし次の点にご注意ください:

ロックタイプインサートには高密度メッキ処理又は潤滑材を塗装したボルトまたはねじの使用をお勧めします。熱処理されたメッキ無しボルトまたはステンレス鋼のボルトを使用する場合は、かじりの影響を最小にしサイクル寿命を最大にするためにモリブデンジスルフィドなどの焼付防止コンパウンドの使用をお勧めします。また、ねじやボルトの磨耗寿命を延ばすためには、ドライフィルム潤滑材またはカドミウムメッキされたPowerCoil(パワーコイル)インサートの使用をお勧めします。

ロックングコイル位置

1D、1.5D、2Dの長さを持つインサートでは、ロックングコイルの中心位置は自由コイル数の1/2となります。2.5Dと3Dのインサートは、2Dインサートのロックングコイル中心位置のタングからの距離と同じ値となります。

ロックタイプインサートは識別し易いように赤色に着色してありますが、希望であればアルコール液で取り除くことが可能です。

着色(赤色)

PowerCoil(パワーコイル)のロックタイプインサートは通常識別のために有機赤色染料で着色されています。この染料はインサートの装着や性能に影響を与えないため、(ほとんどの場合)取り除く必要はありませんが、クリーンルームでの精密機器の組立などで塗料の付着が望ましくない場合には、インサート挿入前に変性アルコール液に浸すことで染料を取り除くことができます。

PowerCoil(パワーコイル) ロックングインサートトルク値

ミリ並目			ミリ細目		
ねじ山 mm*mm	最大トルク (Nm)	最小トルク (Nm)	ねじ山 mm*mm	最大トルク (Nm)	最小トルク (Nm)
M2.2x0.45	0.14	0.02	M8.0x1.00	6.00	0.80
M2.5x0.45	0.23	0.05	M10.0x1.00	10.50	1.40
M3.0x0.50	0.45	0.10	M10.0x1.25	10.50	1.40
M3.5x0.60	0.68	0.12	M12.0x1.25	15.50	2.10
M4.0x0.70	0.90	0.15	M12.0x1.50	15.50	2.10
M5.0x0.80	1.60	0.30	M14.0x1.50	23.50	3.00
M6.0x1.00	3.00	0.40	M16.0x1.50	31.50	4.20
M7.0x1.00	4.50	0.60	M18.0x1.50	42.00	5.50
M8.0x1.25	6.00	0.80	M20.0x1.50	54.00	7.00
M10.0x1.50	10.50	1.40	M22.0x1.50	67.50	9.00
M12.0x1.75	15.50	2.10	M18.0x2.00	42.00	5.50
M14.0x2.00	23.50	3.00	M20.0x2.00	54.00	7.00
M16.0x2.00	31.50	4.20	M22.0x2.00	67.50	9.00
M18.0x2.50	42.00	5.50	M24.0x2.00	80.00	10.50
M20.0x2.50	54.00	7.00	M27.0x2.00	94.00	12.00
M22.0x2.50	67.50	9.00	M30.0x2.00	108.00	14.00
M24.0x3.00	80.00	10.50	M33.0x2.00	122.00	15.50
M27.0x3.00	94.00	12.00	M36.0x2.00	136.00	17.50
M30.0x3.50	108.00	14.00	M39.0x2.00	150.00	19.50
M33.0x3.50	122.00	15.50	M36.0x3.00	136.00	17.50
M36.0x4.00	136.00	17.50	M39.0x3.00	150.00	19.50
M39.0x4.00	150.00	19.50			

ロックングトルク値はMP3329、MP3330、MP3331に従う

PowerCoil(パワーコイル) ロックングインサートトルク値

ユニファイ並目-UNC			ユニファイ細目-UNF		
ねじ山 Inch*TPI	最大トルク (lb in)	最小トルク (lb in)	ねじ山 Inch*TPI	最大トルク (lb in)	最小トルク (lb in)
2x56	1.25	0.19	3x56	0.13	0.44
3x48	2.00	0.44	4x48	0.19	0.63
4x40	3.00	0.63	6x40	6.00	1.00
5x40	4.69	0.81	8x36	9.00	1.50
6x32	6.00	1.00	10x32	13.00	2.00
8x32	9.00	1.50	1/4x28	30.00	3.50
10x24	13.00	2.00	5/16x24	60.00	6.50
12x24	24.00	3.00	3/8x24	80.00	9.50
1/4x20	30.00	4.50	7/16x20	100.00	14.00
5/16x18	60.00	7.50	1/2x20	150.00	18.00
3/8x18	80.00	12.00	9/16x18	200.00	24.00
7/16x14	100.00	16.50	5/8x18	300.00	32.00
1/2x13	150.00	24.00	3/4x16	400.00	50.00
9/16x12	200.00	30.00	7/8x14	600.00	70.00
5/8x11	300.00	40.00	1x12	800.00	90.00
3/4x10	400.00	60.00	11/8x12	900.00	117.00
7/8x9	600.00	82.00	11/4x12	1000.00	143.00
1x8	800.00	110.00	13/8x12	1150.00	165.00
11/8x7	900.00	137.00	11/2x12	1350.00	190.00
11/4x7	1000.00	165.00			
13/8x6	1150.00	185.00			
11/2x6	1350.00	210.00			

ロックングトルク値はNASM8846に従う

注:最大の強度を得るためには、ボルトとインサートコイル全てがかみ合うことが重要となります

PowerCoil(パワーコイル)のロックタイプインサートは顧客の特別な要望に合わせ設計することができます。場合によっては、プリベリントルクを減少させたり増加させることによって特殊な用途に対応させます。特殊な要望がありましたら、お気軽にPowerCoil(パワーコイル)へご相談ください。注:PowerCoil(パワーコイル)のロックタイプインサートの装着にはプレフィンダー式挿入工具が必要となります。他の挿入方法オプションに関しては、PowerCoil(パワーコイル)取り扱い店へお問い合わせください。



Loksert Keylocking inserts (verdrehssichere Gewindebuchsen) sind ein einfach einsetzbares Gewindesystem, ideal zum Ersetzen beschädigter oder verschlissener Gewinde in praktisch allen Werkstoffen – eisenhaltigen, nicht eisenhaltigen und nicht metallischen. Sie sind aus qualitativ hochwertigem, unlegiertem Stahl oder widerstandsfähigem Edelstahl hergestellt. Einstückige Loksert Inserts (Einsätze) werden mit vormontierten Schwalbenschwanz-Keilen geliefert. Die voreingestellten Keile positionieren den Einsatz automatisch in der von der Oberfläche des Mutterwerkstoff aus gemessenen korrekten Einbautiefe. Lokserts sind zur Reparatur und zur Erstellung von Gewinden in einer umfassenden Reihe von Anwendungen geeignet, einschließlich Schmiede- und Gussstücke, und sind besonders gut in Situationen, wo es zu hohem Verschleiß und Schwingungen kommt – z.B. im Bergbau, im Bauwesen und in Erdbaumaschinen.

Les Loksert solid keylocking inserts [solides filets rapportés Loksert à frein de vis] sont un assemblage de filet facile à implanter et idéal pour remplacer les filets endommagés ou usés pour n'importe quel type de matériau, ferreux, non ferreux et non métallique. Ils sont fabriqués à partir d'acier au carbone de haute qualité ou d'acier inoxydable extrêmement résistant à l'usure. Les Loksert inserts [filets rapportés Loksert] en une seule pièce sont fournis avec les clavettes de blocage à queue d'aronde préassemblées. Les clavettes pré-positionnées mettent automatiquement le filet rapporté en place à la profondeur correcte en-dessous de la surface du matériau récepteur. Les Lokserts [filets rapportés Loksert] conviennent à la réparation et à la création de filets pour une large gamme d'applications, y compris pour les forgeages et les moulages, et ils conviennent particulièrement aux situations qui subissent une forte usure et de fortes vibrations, tels que les équipements miniers, le matériel de construction et de terrassement.

Los insertos de seguridad Loksert son de fácil instalación, y su ensamblaje es ideal para reemplazar roscas dañadas o gastadas en, esencialmente, cualquier material – ferroso, no ferroso y no metálico -. Están fabricados con la más alta calidad de acero al carbón o de acero inoxidable. Un inserto loksert se suministra con los arrastres pre-ensamblados. Los filetes de apriete posicionados automáticamente colocan al inserto en la profundidad correcta de la superficie del material de alojamiento. Los lokserts están recomendados para reparación y creación de roscas en un amplio rango de aplicaciones incluyendo herrerías y fundiciones y se recomiendan especialmente para casos de gran desgaste de uso y vibración, tales como minería, construcción y equipo de gran movimiento.

Eigenschaften und Vorzüge

- Solide Buchsen mit verdrehssicheren Keilen, positive mechanische Rotationsfestigkeit
- Hohe Festigkeit und Zuverlässigkeit sorgen für maximale Ausdrehfestigkeit
- Einbau mit Standardbohrern und -gewindebohrern
- Einfacher Einbau – besondere Vorkenntnisse nicht erforderlich
- Für eine umfassende Reihe von Mutterwerkstoffen geeignet
- Schiefes Eindrehen ausgeschlossen
- Einfacher Ausbau, wenn erforderlich
- Kein Mitnehmerzapfen abzubrechen oder zu entfernen
- In metrischen und Zoll- und Zündkerzengrößen erhältlich
- In dünnwandiger und heavy-duty Ausführung erhältlich.

Caractéristiques et avantages

- Une douille solide utilisant des clavettes de blocage fournit une résistance mécanique contre la rotation
- La grande résistance et la fiabilité procurent une résistance maximale à l'arrachement
- L'installation se fait à l'aide de forets et de tarauds standards
- L'installation est simple, aucune compétence spéciale n'est requise
- Ils sont appropriés à l'utilisation dans une gamme variée de matériaux récepteurs
- Impossible à fausser durant l'installation
- Facile à retirer si nécessaire
- Aucun tenon à casser et à retirer
- Disponibles en dimensions métriques, en pouces et en dimensions de bougie d'allumage
- Disponibles avec paroi fine et renforcée

Características y Beneficios

- Sólidos, utilizan filetes de apriete que proporcionan una alta seguridad mecánica contra la rotación.
- Alta resistencia y fiabilidad que proporciona una gran resistencia contra el desplazamiento.
- Se instalan usando machos y brocas standard.
- Instalación sencilla. No requiere de conocimientos especiales
- Recomendados para su uso en un amplio rango de materiales de alojamiento.
- Imposible de confundir las roscas durante la instalación.
- En caso de ser necesario, sencillo proceso de desalajo.
- Sin arrastre que cortar y quitar
- Disponibles en medidas métricas, pulgadas y para bujías
- Disponible en paredes delgadas y para trabajos pesados



Loksert固态型螺纹护套可以简单方便的安装于一些损坏的、磨损的螺纹场合，这些场合可以是有色金属材料，黑色金属材料又或是非金属材料。这种特殊的螺纹护套是由高质量的碳钢或者高性能的不锈钢制成。每一个固态型的螺套都有着预先组装好的燕尾槽键锁装置。这个键锁装置已安置于螺套上，位于母材表面下合适的深度。固态型的螺套在修理和制造螺纹领域有着非常广泛的应用，包括锻铸领域，另外在严重磨损或者振动领域也有着很多的应用，比如采矿业，建筑业等等。

Loksert(ロックサート)の強固なキーロッキングインサートは損傷または磨耗したねじ山の補修に最適で簡単に装着することができます。鉄、非鉄、非金属を含むほとんど全ての材質に対応します。Loksert(ロックサート)のインサートは高品質カーボン鋼または超耐耗性を持つステンレス鋼から造られています。各インサートはあらかじめ一定位置に組み込まれた鳩尾型のロックキーを持ち、このロックキーによってインサートは適正な深さに挿入されます。ロックサートは鍛造や鋳造を含む広範囲における用途でねじ山の補修、形成に適しており、特に採掘、建設、土木機材など磨耗や振動が激しい環境下での用途に適しています。

特征与利益

- 固态型螺套的键锁提供了一个机械式的锁紧功能用于对抗旋转
- 高强度，高稳定度，提供最大的拉力
- 可用标准的钻头 and 丝锥安装
- 安装简单，没有特殊工具要求
- 可适用于很多种的母材
- 安装时螺纹不可过
- 如果必须的话，可以很方便的移除
- 没有需要折断或者移除的尾部安装柄
- 类别有公制尺寸，英制尺寸，火花塞
- 有着薄型或者厚型类别

製品の特徴と利点

- ロッキングキーを利用した強度の高いブッシングによって、ブッシングの戻り止めに有効な機械的ロックが働きます
- 高い強度と信頼性が最適な最大引き抜き強度を与えます
- 標準規格のドリルとタップで装着できます
- 簡単に装着できます-特別な技術を必要としません
- 広い範囲の母材材料に対応します
- 挿入時にねじ山がずれません
- 必要に応じて簡単に取り外せます
- タングを折り取る必要がありません
- メートルサイズ、インチサイズ、スパークプラグサイズが揃ってあります
- 薄肉タイプと高耐久性タイプがあります



powercoil[®]

wire thread insert system



BORDO[®]

INDUSTRIAL TOOLS

Bordo Europe VAT 0825.518.302

Industrieweg (BAA) 2, B9200, Dendermonde, Belgium

Telephone +32 (0) 52 412110 **Facsimile** +32 (0) 52 410753

Email bordoeurope@bordo.com.au **Web** www.bordo.com.au

Bordo International Pty Ltd ABN 96 005 125 833

3 Kingston Park Court Scoresby Victoria 3179 Australia

Telephone +61 3 9212 7000 **Facsimile** +61 3 9212 7070

Email info@bordo.com.au **Web** www.bordo.com.au

Part No. 9910-CAT0315.BE



9 3 2 6 5 1 8 1 3 9 1 8 8